

Advanced Solutions for USB Protections

Abstract

The AIC1526 is a dual high-side power switch for self-powered and bus-powered USB applications. This application note describes how the AIC1526 provides the power switching and over-current protection. The items such as bus-powered hubs and self-powered hubs are first introduced, after which, the power distribution of USB specification (version 1.0) and the key points of AIC1526 application will be followed.

Introduction

The universal serial bus (USB) interface is a 12 Mb/s, multiplexed serial bus designed for low to medium speed PC peripherals. The USB interface consists of four lines (see Figure 1). Two data lines(D+,D-) are used for differential data transmission and the other two power lines are for power distribution of the 5 volts. The USB interface is conceived for hot-plug-unplug of peripheral devices to achieve the real "plug-and-play" function.

- 2 power lines:
 - 5V
 - GND
- 2 data lines
 - D+
 - D-

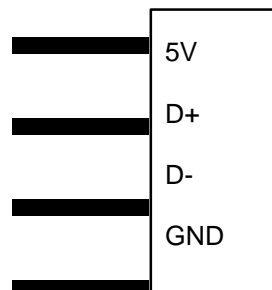

Figure 1. USB Connector

Hubs provide distributions of data and power to downstream (away from the host) devices and communicate with the host. A hub consists of one upstream port and several downstream ports (see

Figure 2). By connecting the serial connecting hubs, the number of devices can be increased up to the maximum of 127 devices.

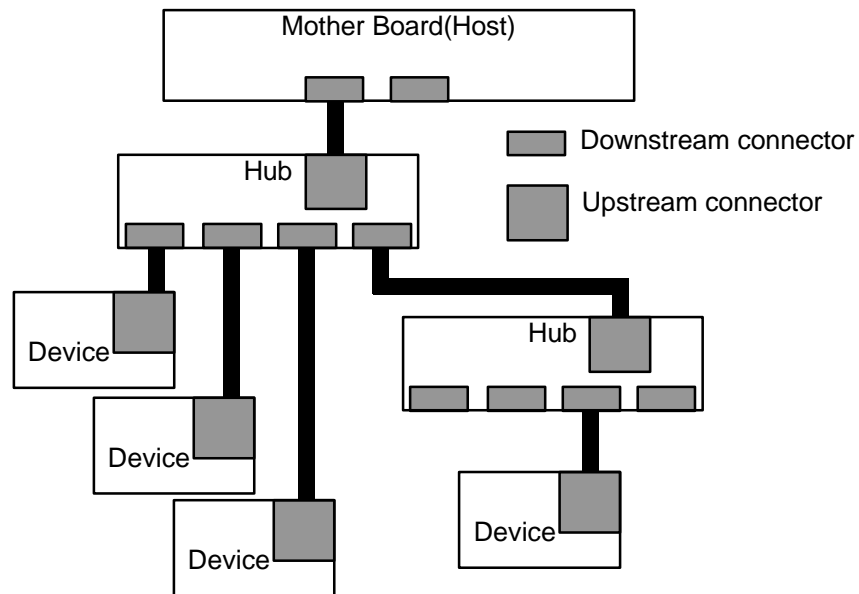

Figure 2. Connections of USB

Self-powered hubs have a **local** power supply. The hubs in PCs (host), stand-alone hubs, and monitors are usually self-powered hubs. The self-powered hubs are required to limit and report over-current conditions and have the ability of supplying up to 500mA to each downstream port (see Figure 3).

Bus-powered hubs obtain all power from

upstream self-powered hubs, and may supply 100mA or more to each downstream port if the input power budget does not exceed. The bus-powered hub must provide s power switching for downstream ports on each port basis or have a single switch for all of the ports (gang-mode power control).

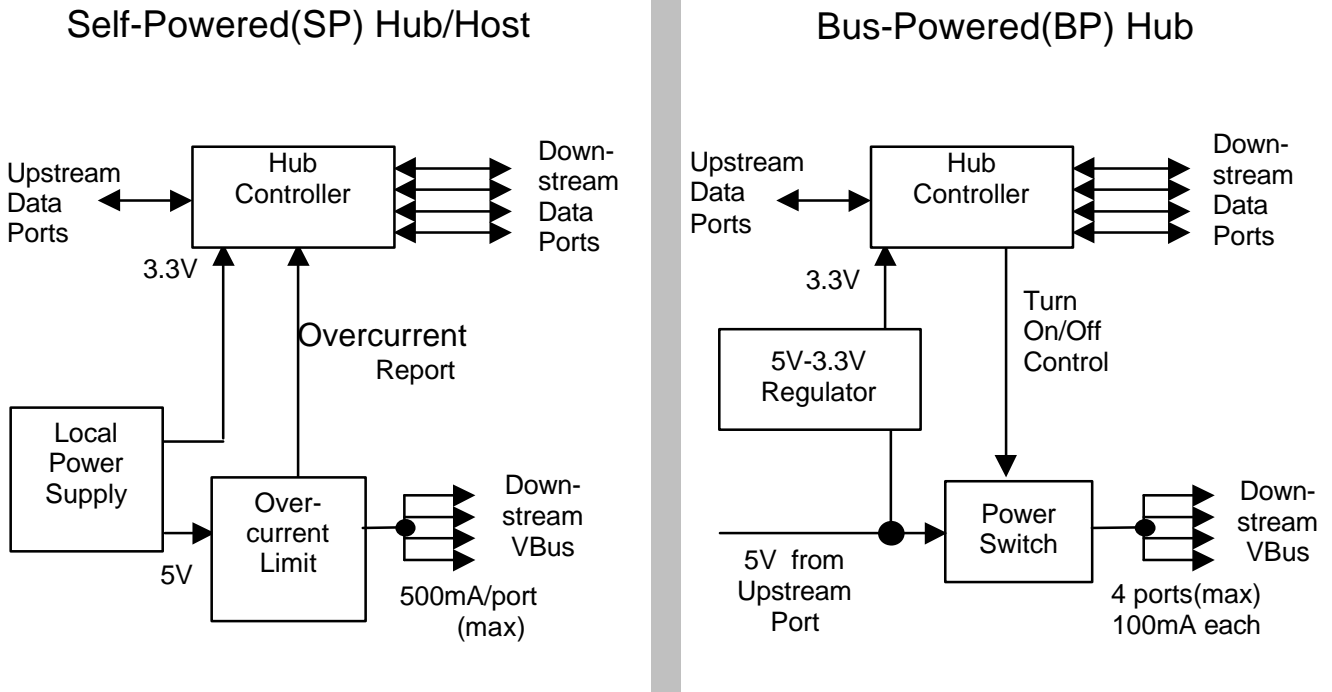

Figure 3. Self-Powered Hub & Bus-Powered Hub

USB Power Distribution

Voltage requirements:

The **Self-powered hub** has an internal power supply. The DC output voltage, measured at the board side connector of the self-powered hub, must in the range of 4.75V ~ 5.25V.

The **Bus-powered hub** obtains all power from an upstream self-power hub. The upstream cable connector must receive a minimum of 4.65V, while each downstream port provides a minimum of 4.40V at 100mA.

Output current limits:

Because the power is supplied from an internal power supply in self-powered hub, the over-current protection is required on the output

ports for safety reason. UL limits require ports to deliver no more than 5A (including short circuit currents).

The power distribution for a self-powered hub can be designed either with one over-current protection device each output port or by ganging multiple ports to one over-current protection device. The minimum output current limit of each output port is 500mA for the self-powered hubs, but the maximum output current limit depends on the numbers of output ports of a self-powered hub. If there is only one output ports of a self-powered hub, the maximum output current limit is 5A for this hub to supply maximum current 5A to ganging multiple downstream ports. In the same way, if a self-powered hub has two output ports, the maximum output current limit is $5A/2=2.5A$ for

each output port to supply maximum current 2.5A to downstream ports. Table 1 shows the minimum and maximum output current limit of each port for different number of ports of self-powered hub. A self-powered hub with 4 output ports is the most popular type in recent market, and the output

current limit is typically 700mA~1.25A.

A bus-powered hub receives power from upstream port up to 500mA. The output current of each port doesn't have to be limited, but needs to be turned on or turned off.

USB Current Limits Requirements per Ports			
<ul style="list-style-type: none"> •Minimum current per port is 500mA. •If a channel has n ports, maximum current per port is 5A/n.(n≤7) 			
	Minimum Current/Port Individual Port	Maximum Current Individual Port	Total Maximum Current Combining All Ports
1 Port	500mA	5.0A	5.0A
2 Ports	500mA	2.5A	5.0A
3 Ports	500mA	1.6A	5.0A
4 Ports	500mA	1.25A	5.0A
5 Ports	500mA	1.0A	5.0A
6 Ports	500mA	0.83A	5.0A
7 Ports	500mA	0.71A	5.0A

A hub with 4 ports is the most widely used.

Table 1. The Minimum and Maximum Current Limit

Transient Requirements:

When a function or hub is plugged into the network, inrush current and voltage droop is induced. The target maximum droop in the hub V_{BUS} is 330mV or about 10% of the nominal signal swing from the function. In order to reach this target, the USB specification (version 1.0) about

the load and the hub port V_{BUS} power lines must meet the following conditions (see Figure 4):
 The hub port V_{BUS} power lines must be bypassed with no less than a 120µF tantalum capacitor.
 The maximum load that can be placed at the downstream end of a cable is 10µF in parallel with 44Ω.

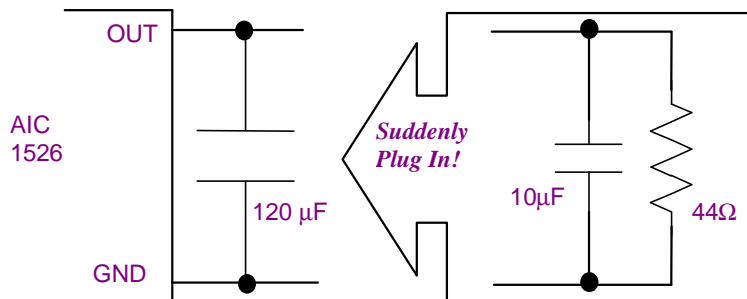

Figure 4. Capacitors of Power Lines and Devices

Application of AIC1526

Figure 5 shows that the AIC1526 contains 2 high-side power switches. Each switch provides controllable power switching, over-current protection, thermal shutdown, and under voltage lockout (UVLO). Figure 6 shows a typical application circuit. Each port has an enable pin, a flag pin, and an output pin:

- The enable pin (CTL) is the input turn on/off signal of the port. CTL signal is active low for AIC1526-0, and active high for AIC1526-1.

- The flag pin (FLG) is the indication of normal/fault. If the operation is normal, the flag signal is high. Either one of input under voltage, output current limit and thermal shutdown occurs, the flag signal is pulled low.
- The output pin is the controlled output to downstream devices. The power switch between the "IN" pin and the "OUT" pin is a low on-resistance (typical 150mΩ) MOSFET.

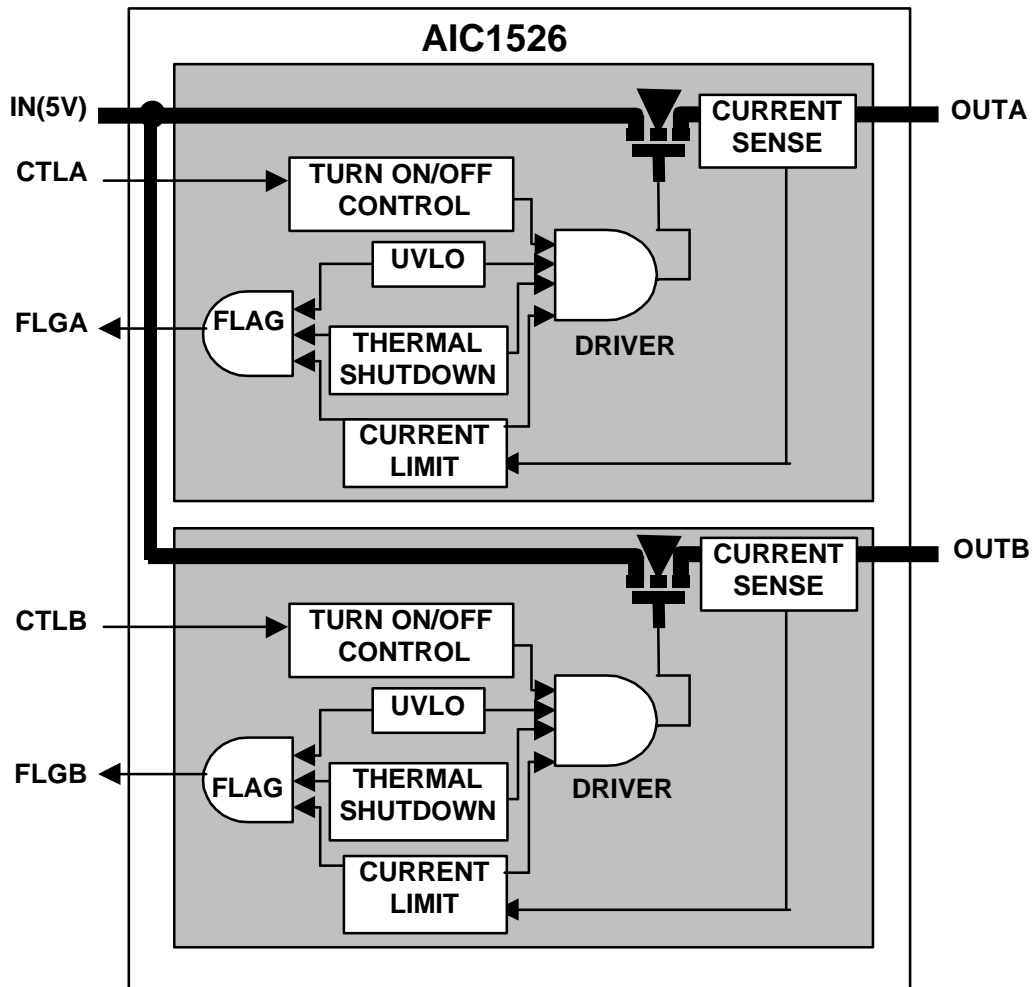

Figure 5. The Block Diagram of AIC1526

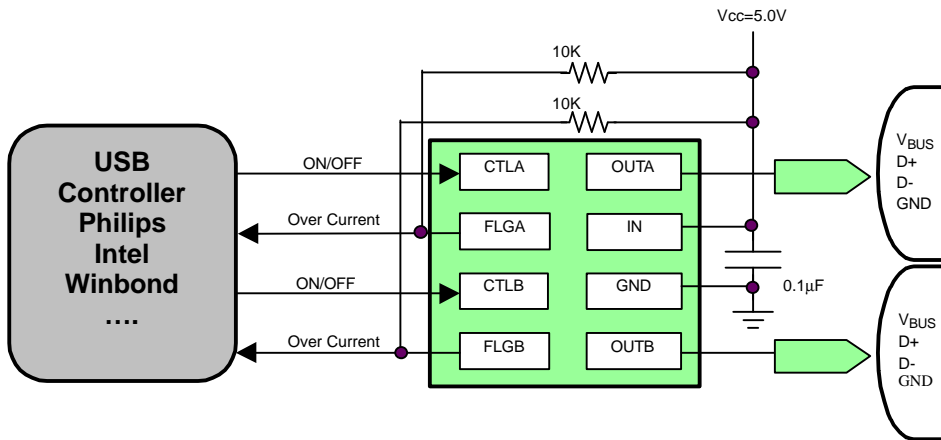

Figure 6. The Typical Application Circuit of AIC1526

Voltage and Current Transient

In order to provide a good power quality for suddenly plugged/unplugged downstream devices, the voltage and current transient must be controlled. The ferrite beads and the bypass capacitors can be used to reduce current surge and voltage spike, as well as decrease electromagnetic interference (EMI).

When the downstream device is suddenly plugged into the network, the voltage transient on the input capacitance of the downstream device will induce the current surge. The ferrite beads are

recommended in series with all power and ground connector pins (see Figure 7). The ferrite bead is similar to a high permeability inductance wherein the high frequency impedance attenuates the high frequency current, and the DC current passes freely.

When the downstream device is suddenly unplugged, the current transient of the wire inductance causes the voltage spike. A bypass capacitor (0.01µF/25V) should be installed from V_{BUS} pin to ground pin at each connector as closer as possible (see Figure 7).

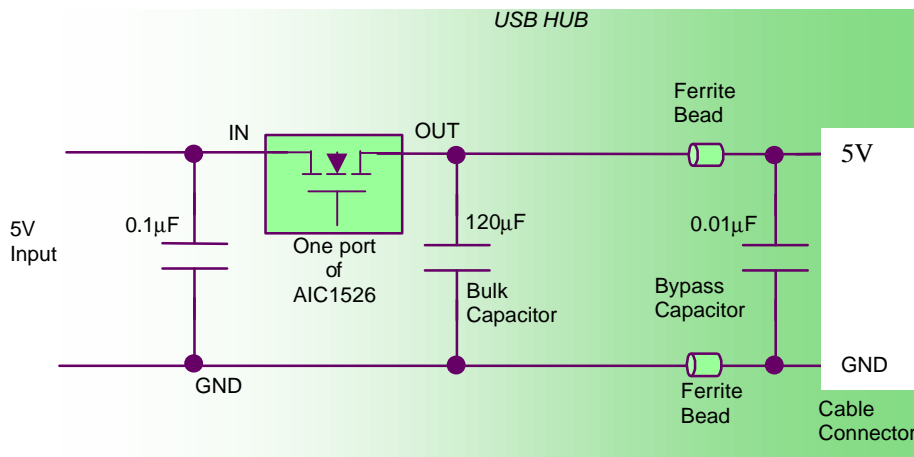

Figure 7. Ferrite Beads and Bypass Capacitors of USB Hub

Error Flag Signal Filtering

The output current limit of each port is 1.0A for AIC1526. If the continuous current is above 1.0A, the flag signal will be pulled low to tell the hub controller the operation is abnormal. However, the current surge caused by hot-plug-in is often excessive to trigger the flag signal to be pulled low. If the inrush current is still large enough to trigger the flag even the ferrite beads are already added, it's necessary to add the low-pass filter between

the FLAG pin to the hub controller. Figure 8 shows that the low-pass filter with time constant is equal to 1ms. Through the equation (1), we can obtain that the hub controller will receive 4.75V after 52μs since the flag signal starts to be pulled low.

$$4.75 = 5e^{-t/1\text{ms}} \Rightarrow t = 52\mu\text{S} \quad (1)$$

Because the transient period during hot-plug is always 20~30 μS, the RC filter prevents the error flag from sending to the hub controller.

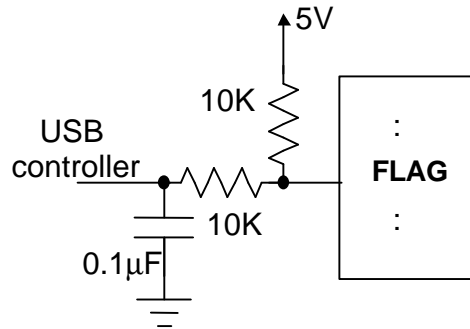

Figure 8. Low-Pass Filter to Prevent the Error Flag

Summary

Because USB is a hot-plug/unplug system, its components are subject to electrostatic discharge (ESD). The AIC1526 is designed to withstand human body model ESD test. To assure robust and maintenance-free protections, it's necessary to place low ESR ceramic bypass capacitors as closely as possible between the IN and OUT pins

to increase the ESD immunity. To prevent excessive voltage droop during hot-plug, the power lines must be bypassed with an output tantalum capacitor. Besides, ferrite beads and small bypass capacitors are recommended in series with all power and ground connector pins to reduce inrush current and decrease EMI.