

2N4416A / ITE4416

N-Channel JFET High Frequency Amplifier



T-31-25

2N4416A / ITE4416

FEATURES

- Low Noise
- Low Feedback Capacitance
- Low Output Capacitance
- High Transconductance
- High Power Gain

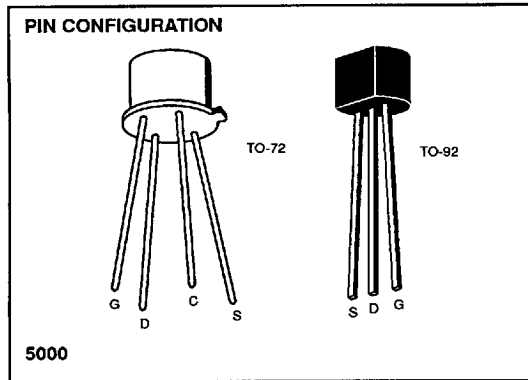

ABSOLUTE MAXIMUM RATINGS

($T_A = 25^\circ\text{C}$ unless otherwise noted)

Gate-Source or Gate-Drain Voltage	
2N4416, ITE4416	-30V
2N4416A	-35V
Gate Current	10mA
Storage Temperature Range	
2N4416/2N4416A	-65°C to +200°C
ITE4416	-55°C to +150°C
Operating Temperature Range	
2N4416/2N4416A	-65°C to +200°C
ITE4416	-55°C to +135°C
Lead Temperature (Soldering, 10sec)	+300°C
Power Dissipation	300mW
Derate above 25°C	
2N4416/2N4416A	1.7mW/°C
ITE4416	2.7mW/°C

NOTE: Stresses above those listed under "Absolute Maximum Ratings" may cause permanent damage to the device. These are stress ratings only and functional operation of the device at these or any other conditions above those indicated in the operational sections of the specifications is not implied. Exposure to absolute maximum rating conditions for extended periods may affect device reliability.

ORDERING INFORMATION

Part	Package	Temperature Range
2N4416	Hermetic TO-72	-55°C to +135°C
2N4416A	Hermetic TO-72	-55°C to +135°C
X2N4416	Sorted Chips in Carriers	-55°C to +135°C
ITE4416	Plastic TO-92	-55°C to +135°C



2N4416A / ITE4416

T-31-25

2N4416A / ITE4416

ELECTRICAL CHARACTERISTICS ($T_A = 25^\circ\text{C}$ unless otherwise specified)

SYMBOL	PARAMETER		MIN	MAX	UNITS	TEST CONDITIONS
I_{GSS}	Gate Reverse Current			-0.1	nA	$V_{GS} = -20V, V_{DS} = 0$ $T_A = 150^\circ\text{C}$
				-0.1	μA	
BV_{GSS}	Gate-Source Breakdown Voltage	2N4416/ITE4416	-30		V	$I_G = -1\mu\text{A}, V_{DS} = 0$
		2N4416A	-35			
$V_{GS(off)}$	Gate-Source Cutoff Voltage	2N4416/ITE4416		-6		$V_{DS} = 15V, I_D = 1\text{nA}$
		2N4416A	-2.5	-6		
$V_{GS(f)}$	Gate-Source Forward Voltage			1	V	$I_G = 1\text{mA}, V_{DS} = 0$
I_{DSS}	Drain Current at Zero Gate Voltage		5	15	mA	$V_{DS} = 15V, V_{GS} = 0$ $f = 1\text{kHz}$
g_{fs}	Common-Source Forward Transconductance		4500	7500	μS	
g_{os}	Common-Source Output Conductance			50	μS	$f = 1\text{MHz}$
C_{rfs}	Common-Source Reverse Transfer Capacitance (Note 1)			0.8	pF	
C_{iss}	Common-Source Input Capacitance (Note 1)			4	pF	
C_{oss}	Common-Source Input Capacitance (Note 1)			2		

ELECTRICAL CHARACTERISTICS (Continued) ($T_A = 25^\circ\text{C}$ unless otherwise specified)

SYMBOL	PARAMETER	100MHz		400MHz		UNITS	TEST CONDITIONS
		MIN	MAX	MIN	MAX		
g_{iss}	Common-Source Input Conductance		100		1000	μS	$V_{DS} = 15V, V_{GS} = 0$ (Note 1)
b_{iss}	Common-Source Input Susceptance		2500		10,000		
g_{oss}	Common-Source Output Conductance		75		100		
b_{oss}	Common-Source Output Susceptance		1000		4000		
g_{fs}	Common-Source Forward Transconductance			4000			
G_{ps}	Common-Source Power Gain	18		10		dB	$V_{DS} = 15V, I_D = 5\text{mA}$ (Note 1)
NF	Noise Figure (Note 1)		2		4		$V_{DS} = 15V, I_D = 5\text{mA}, R_G = 1\text{k}\Omega$

NOTE 1: For design reference only, not 100% tested.