

16-bit dual supply translating transceiver; (3-State)

74ALVC164245

FEATURES

- Wide supply voltage range
 - A port: 1.2 to 3.6V
 - B port: 1.2 to 5.5V
- Complies with JEDEC standard no. 8-1A
- Control inputs voltage range from 2.7V to 5.5V
- CMOS low power consumption
- Direct interface with TTL levels

DESCRIPTION

The 74ALVC164245 is a high-performance, low-power, low-voltage, Si-gate CMOS device, superior to most advanced CMOS compatible TTL families.

The 74ALVC164245 is a 16-bit (dual-octal) translating transceiver and is designed to interface between a 5V bus and 3V bus in a mixed 3V/5V supply environment. This device can be used as two 8-bit transceivers or one 16-bit transceiver. The direction control inputs (1DIR, 2DIR) determine the direction of the data flow. nDIR (active HIGH) enables data from nA ports to nB ports. nDIR (active LOW) enables data from nB ports to nA ports. The output enable inputs (1OE, 2OE), when HIGH, disable both nA and nB ports by placing them in a high impedance OFF-state. The nB ports interface with the 5V bus. The nA ports interface with the 3V bus. In suspend mode, when one of the supply voltages is zero, there will be no current flow from the non zero supply towards the zero supply. $V_{CC1} \geq V_{CC2}$ (except in suspend mode).

PIN CONFIGURATION

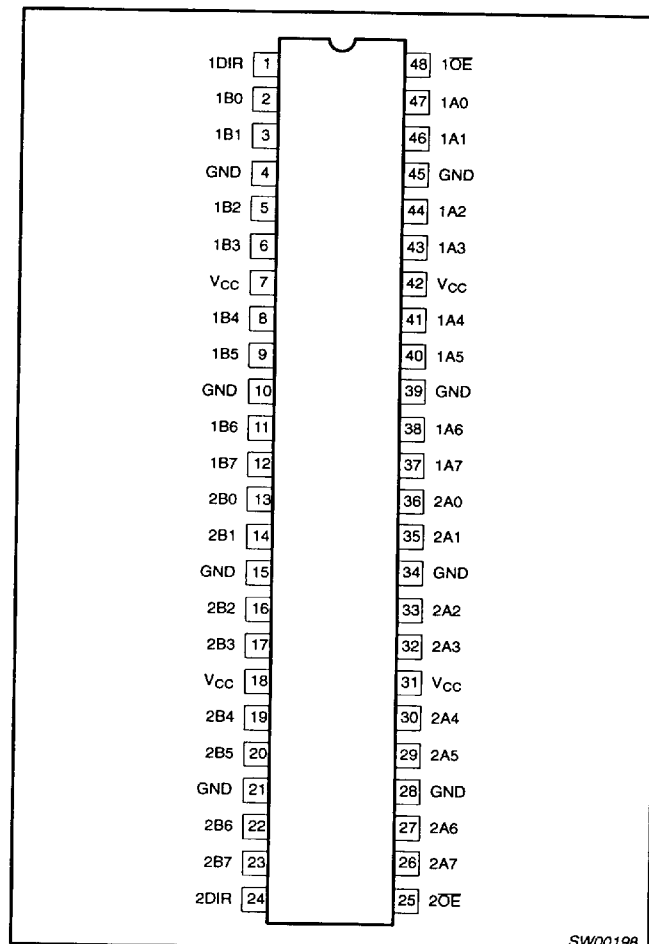

SW00198

ORDERING INFORMATION

PACKAGES	TEMPERATURE RANGE	OUTSIDE NORTH AMERICA	NORTH AMERICA	DWG NUMBER
48-Pin Plastic SSOP Type III	-40°C to +85°C	74ALVC164245 DL	AC164245 DL	SOT370-1
48-Pin Plastic TSSOP Type II	-40°C to +85°C	74ALVC164245 DGG	AC164245 DGG	SOT362-1

QUICK REFERENCE DATA

GND = 0V; T_{amb} = 25°C; t_r = t_f ≤ 2.5ns

SYMBOL	PARAMETER	CONDITIONS	TYPICAL	UNIT
t _{PHL} /t _{PLH}	Propagation delay nA to nB nB to nA	C _L = 50pF V _{CC1} = 5.0V V _{CC2} = 3.3V	3.7 3.1	ns
C _I	Input capacitance		5	pF
C _{I/O}	Input/output capacitance		10	pF
C _{PD}	Power dissipation capacitance per gate	V _I = GND to V _{CC} ¹	20	pF

NOTES:

- C_{PD} is used to determine the dynamic power dissipation (P_D in μW):
 $P_D = C_{PD} \times V_{CC}^2 \times f_i + \sum (C_L \times V_{CC}^2 \times f_o)$ where:
 f_i = input frequency in MHz; C_L = output load capacity in pF;
 f_o = output frequency in MHz; V_{CC} = supply voltage in V;
 $\sum (C_L \times V_{CC}^2 \times f_o)$ = sum of outputs.

16-bit dual supply translating transceiver; (3-State)

74ALVC164245

PIN DESCRIPTION

PIN NUMBER	SYMBOL	NAME AND FUNCTION
1	1DIR	Direction control
2, 3, 5, 6, 8, 9, 11, 12	1B0 to 1B7	Data inputs/outputs
4, 10, 15, 21, 28, 34, 39, 45	GND	GND
7, 18	V _{CC1}	Positive supply voltage (5V bus)
13, 14, 16, 17, 19, 20, 22, 23	2B0 to 2B7	Data inputs/outputs
24	2DIR	Direction control
25	2 $\overline{O}E$	Output enable input (active LOW)
26, 27, 29, 30, 32, 33, 35, 36	2A7 to 2A0	Data inputs/outputs
31, 42	V _{CC2}	Positive supply voltage (3V bus)
37, 38, 40, 41, 43, 44, 46, 47	1A7 to 1A0	Data inputs/outputs
48	1 $\overline{O}E$	Output enable input (active LOW)

FUNCTION TABLE

INPUTS		OUTPUTS	
n $\overline{O}E$	nDIR	nAn	nBn
L	L	A = B	inputs
L	H	inputs	B = A
H	X	Z	Z

H = HIGH voltage level
 L = LOW voltage level
 X = don't care
 Z = high impedance OFF-state

LOGIC SYMBOL (IEEE/IEC)

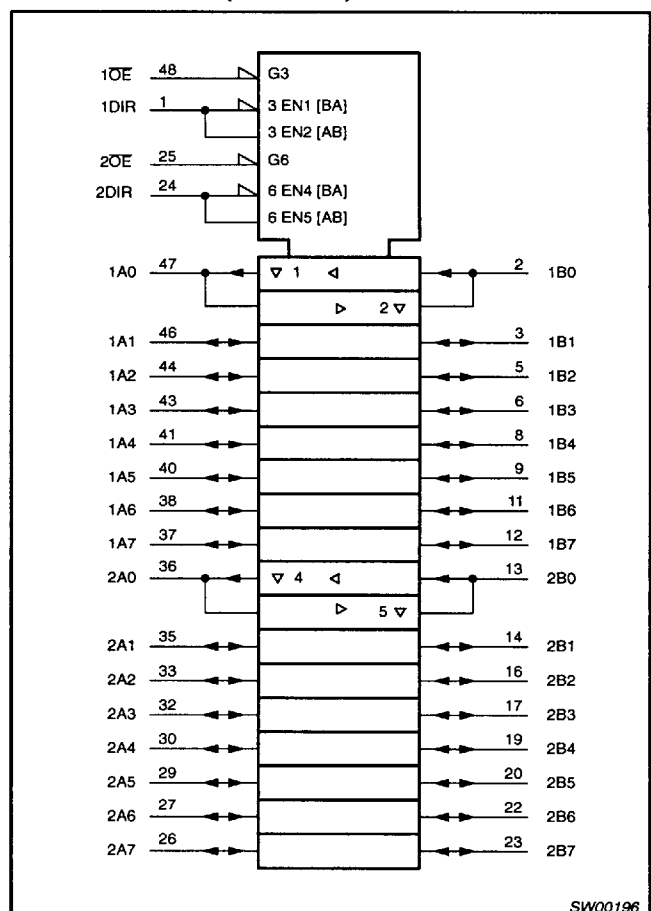

LOGIC SYMBOL

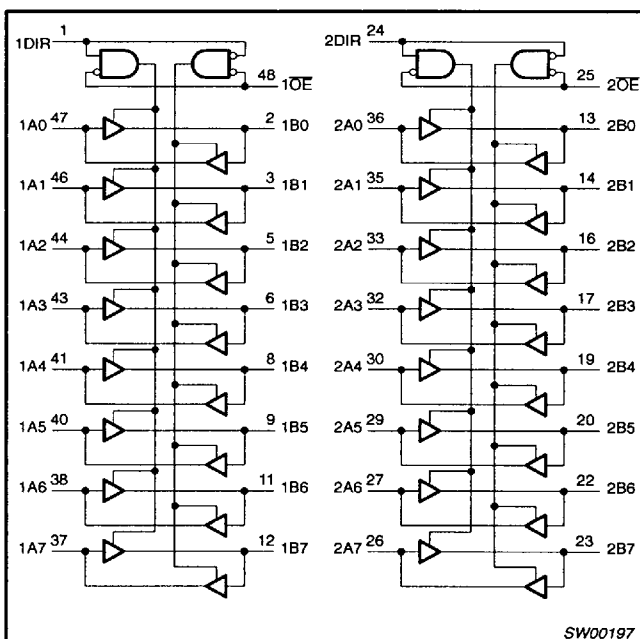

16-bit dual supply translating transceiver; (3-State)

74ALVC164245

ABSOLUTE MAXIMUM RATINGS^{1, 2}

In accordance with the Absolute Maximum Rating System (IEC 134)
 Voltages are referenced to GND (ground = 0V)

SYMBOL	PARAMETER	CONDITIONS	RATING	UNIT
V _{CC1}	DC supply voltage (B Port)		-0.5 to +6.0	V
V _{CC2}	DC supply voltage (A Port)		-0.5 to +4.6	V
I _{IK}	DC input diode current	V _I < 0	-50	mA
V _I	DC input voltage	Note 3	-0.5 to +5.5	V
V _{I/O}	DC input voltage range for I/Os		-0.5 to V _{CC} + 0.5	V
I _{OK}	DC output diode current	V _O > V _{CC} or V _O < 0	± 50	mA
V _O	DC output voltage	Note 3	-0.5 to V _{CC} + 0.5	V
I _O	DC output source or sink current	V _O = 0 to V _{CC}	± 50	mA
I _{GND} , I _{CC}	DC V _{CC} or GND current		± 100	mA
T _{stg}	Storage temperature range		-60 to +150	°C
P _{TOT}	Power dissipation per package -plastic medium-shrink SO (SSOP) -plastic mini-pack (TSSOP)	For temperature range: -40 to +125 °C above +55°C derate linearly with 11.3 mW/K above +55°C derate linearly with 8 mW/K	850 600	mW

NOTES:

- Stresses beyond those listed may cause permanent damage to the device. These are stress ratings only and functional operation of the device at these or any other conditions beyond those indicated under "recommended operating conditions" is not implied. Exposure to absolute-maximum-rated conditions for extended periods may affect device reliability.
- The performance capability of a high-performance integrated circuit in conjunction with its thermal environment can create junction temperatures which are detrimental to reliability. The maximum junction temperature of this integrated circuit should not exceed 150°C.
- The input and output voltage ratings may be exceeded if the input and output current ratings are observed.

RECOMMENDED OPERATING CONDITIONS

SYMBOL	PARAMETER	CONDITIONS	LIMITS		UNIT
			MIN	MAX	
V _{CC1}	DC supply voltage (for max. speed performance) (B Port)	V _{CC1} ≥ V _{CC2}	2.7	5.5	V
V _{CC2}	DC supply voltage (for max. speed performance) (A Port)	V _{CC1} ≥ V _{CC2}	2.7	3.6	V
V _{CC1}	DC supply voltage (for low-voltage applications) (B Port)	V _{CC1} ≥ V _{CC2}	1.5	5.5	V
V _{CC2}	DC supply voltage (for low-voltage applications) (A Port)	V _{CC1} ≥ V _{CC2}	1.5	3.6	V
V _I	DC Input voltage range		0	5.5	V
V _{I/O}	DC Input voltage range for I/Os	A Port	0	V _{CC2}	V
V _{I/O}	DC Output voltage range for I/Os	B Port	0	V _{CC1}	V
V _O	DC Output voltage range	A Port	0	V _{CC2}	V
V _O	DC Output voltage range	B Port	0	V _{CC1}	V
T _{amb}	Operating free-air temperature range		-40	+85	°C
t _r , t _f	Input rise and fall times	V _{CC} = 1.2 to 2.0V V _{CC} = 2.7 to 3.0V V _{CC} = 3.0 to 5.5V	0 0 0	50 20 10	ns/V

16-bit dual supply translating transceiver; (3-State)

74ALVC164245

DC ELECTRICAL CHARACTERISTICS

SYMBOL	PARAMETER	TEST CONDITIONS	LIMITS			UNIT
			Temp = -40°C to +85°C			
			MIN	TYP ¹	MAX	
V _{IH}	HIGH level Input voltage (B Port)	V _{CC} = 4.5 to 5.5V (Note 2)	2.0			V
V _{IH}	HIGH level Input voltage (A Port)	V _{CC} = 2.7 to 3.6V (Note 2)	2.0			V
V _{IL}	LOW level Input voltage (B Port)	V _{CC} = 4.5 to 5.5V (Note 2)			0.8	V
V _{IL}	LOW level Input voltage (A Port)	V _{CC} = 2.7 to 3.6V (Note 2)			0.8	V
V _{OH}	HIGH level output voltage (B Port)	V _{CC} = 4.5V; V _I = V _{IH} or V _{IL} ; I _O = -100μA	V _{CC} - 0.2	V _{CC}		V
		V _{CC} = 4.5V; V _I = V _{IH} or V _{IL} ; I _O = -24mA	V _{CC} - 0.8			
		V _{CC} = 4.5V; V _I = V _{IH} or V _{IL} ; I _O = -12mA	V _{CC} - 0.5			
V _{OH}	HIGH level output voltage (A Port)	V _{CC} = 3.0V; V _I = V _{IH} or V _{IL} ; I _O = -100μA	V _{CC} - 0.2			V
		V _{CC} = 3.0V; V _I = V _{IH} or V _{IL} ; I _O = -24mA	V _{CC} - 1.0			
		V _{CC} = 2.7V; V _I = V _{IH} or V _{IL} ; I _O = -12mA	V _{CC} - 0.6	V _{CC}		
V _{OL}	LOW level output voltage (B Port)	V _{CC} = 4.5V; V _I = V _{IH} or V _{IL} ; I _O = 100μA			0.20	V
		V _{CC} = 4.5V; V _I = V _{IH} or V _{IL} ; I _O = 24mA			0.55	
		V _{CC} = 4.5V; V _I = V _{IH} or V _{IL} ; I _O = 12mA			0.40	
V _{OL}	LOW level output voltage (A Port)	V _{CC} = 3.0V; V _I = V _{IH} or V _{IL} ; I _O = 100μA			0.20	V
		V _{CC} = 3.0V; V _I = V _{IH} or V _{IL} ; I _O = 24mA			0.55	
		V _{CC} = 2.7V; V _I = V _{IH} or V _{IL} ; I _O = 12mA			0.40	
I _I	Input leakage current	V _{CC} = 3.6V; V _I = 5.5V or GND	Control pins	±0.1	±5	μA
		V _{CC} = 3.6V; V _I = V _{CC} or GND	Data input pins	±0.1	±5	
I _{IHZ} /I _{ILZ}	Input current for common I/O pins (B Port)	V _{CC} = 5.5V; V _I = V _{CC} or GND		±0.1	±15	μA
I _{IHZ} /I _{ILZ}	Input current for common I/O pins (A Port)	V _{CC} = 3.6V; V _I = V _{CC} or GND		±0.1	±15	μA
I _{OZ}	3-State output OFF-state current (B Port)	V _{CC} = 5.5V; V _I = V _{IH} or V _{IL} ; V _O = V _{CC} or GND		0.1	±10	μA
I _{OZ}	3-State output OFF-state current (A Port)	V _{CC} = 3.6V; V _I = V _{IH} or V _{IL} ; V _O = V _{CC} or GND		0.1	±10	μA
I _{CC}	Quiescent supply current (B Port)	V _{CC} = 5.5V; V _I = V _{CC} or GND; I _O = 0		0.2	40	μA
I _{CC}	Quiescent supply current (A Port)	V _{CC} = 3.6V; V _I = V _{CC} or GND; I _O = 0		0.2	40	μA
ΔI _{CC}	Additional quiescent supply current per input pin (B Port)	V _{CC} = 2.7V to 3.6V; V _I = V _{CC2} - 0.6V; I _O = 0		5	500	μA
ΔI _{CC}	Additional quiescent supply current per control pin (A Port)	V _{CC} = 2.7V to 3.6V; V _I = V _{CC2} - 0.6V; I _O = 0		5	500	μA

NOTES:

- All typical values are at V_{CC1} = 5.0V, V_{CC2} = 3.3V and T_{amb} = 25°C.
- If V_{CC2} < 2.7V, the switching levels at all inputs are not TTL compatible.

16-bit dual supply translating transceiver; (3-State)

74ALVC164245

AC CHARACTERISTICS

GND = 0V; $t_R = t_F = 2.5\text{ns}$; $C_L = 50\text{pF}$; $R_L = 500\Omega$; $T_{\text{amb}} = -40^\circ\text{C}$ to $+85^\circ\text{C}$.

SYMBOL	PARAMETER	WAVEFORM	LIMITS				UNIT
			$V_{CC1} = 5.0V \pm 0.5V$ $V_{CC2} = 3.3V \pm 0.3V$		$V_{CC1} = 5.0V \pm 0.5V$ $V_{CC2} = 2.7V$		
			TYP ¹	MAX	TYP ¹	MAX	
t_{PHL} t_{PLH}	Propagation delay nAn to nBn	1	3.9	5.5	4.3	6.5	ns
t_{PHL} t_{PLH}	Propagation delay nBn to nAn	1	3.6	5.0	4.1	6.0	ns
t_{PZH} t_{PZL}	3-State output enable time nOE to nAn	2	5.5	8.0	6.2	9.0	ns
t_{PZH} t_{PZL}	3-State output enable time nOE to nBn	2	4.9	7.0	5.5	8.0	ns
t_{PHZ} t_{PLZ}	3-State output disable time nOE to nAn	2	4.9	7.0	5.2	7.5	ns
t_{PHZ} t_{PLZ}	3-State output disable time nOE to nBn	2	5.2	7.5	5.5	8.0	ns

NOTE:

1. All typical values are at $V_{CC1} = 5.0V$, $V_{CC2} = 3.3V$ and $T_{\text{amb}} = 25^\circ\text{C}$.

AC WAVEFORMS

$V_M = 1.5V$ at $V_{CC} \leq 3.6V$

$V_M = 0.5 * V_{CCA}$ at $V_{CCA} \geq 4.5V$.

$V_X = V_{OL} + 0.3V$ at $V_{CC} \leq 3.6V$

$V_X = V_{OL} + 0.1 * (V_{OH} - V_{OL})$ at $V_{CCA} \geq 4.5V$

$V_Y = V_{OH} - 0.3V$ at $V_{CC} \leq 3.6V$

$V_Y = V_{OH} - 0.1 * (V_{OH} - V_{OL})$ at $V_{CCA} \geq 4.5V$

V_{OL} and V_{OH} are the typical output voltage drops that occur with the output load.

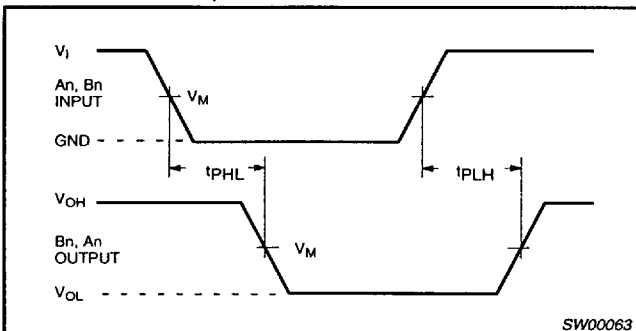

Waveform 1. Waveforms showing the input (nAn, nBn) to output (nBn, nAn) propagation delays

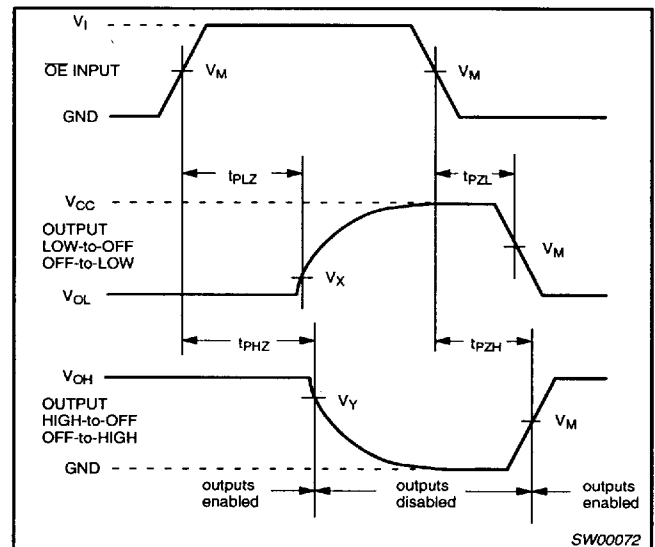

Waveform 2. Waveform showing the 3-State enable and disable times

16-bit dual supply translating transceiver; (3-State)

74ALVC164245

TEST CIRCUIT

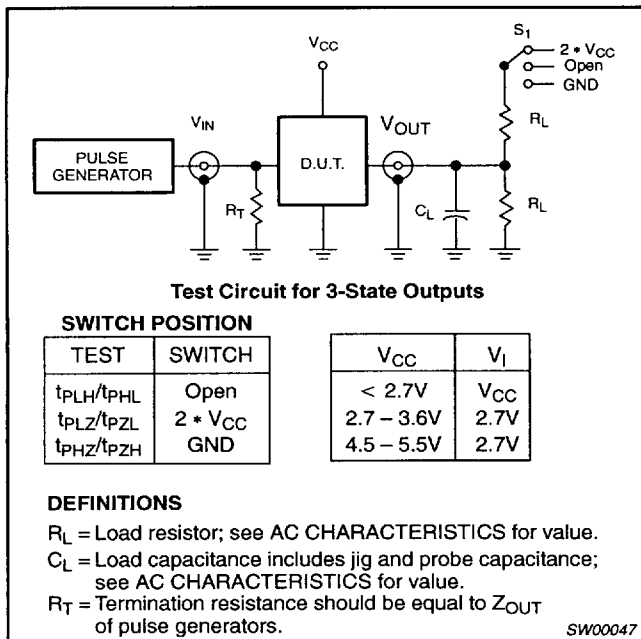

Figure 1. Load circuitry for switching times

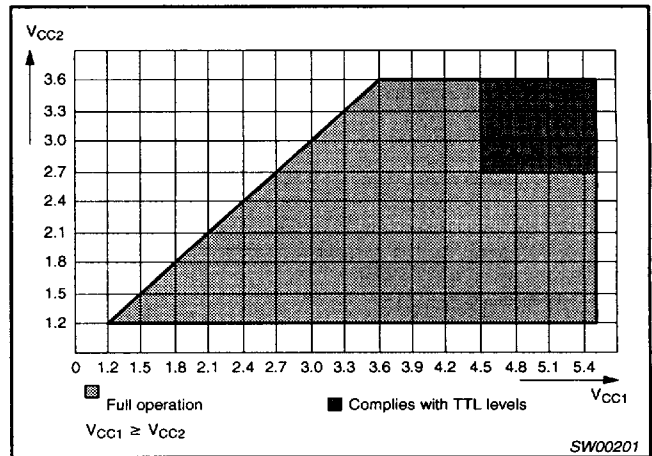

Figure 2. Supply operating area

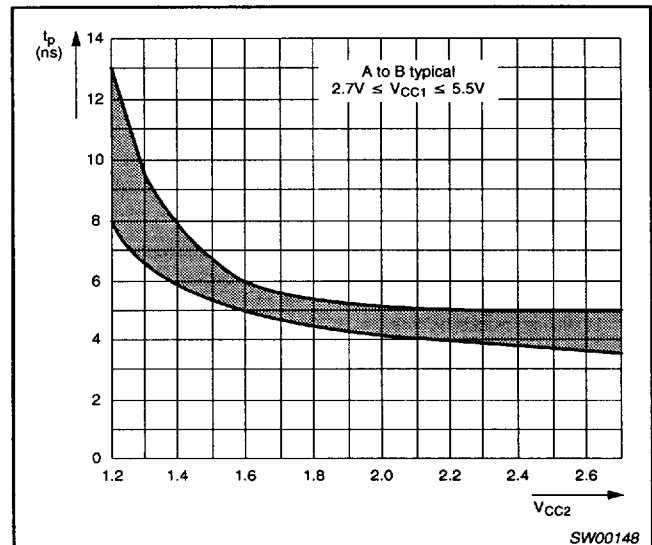

Figure 3. Propagation delay as a function of the supply voltage, V_{CC2}

16-bit dual supply translating transceiver; (3-State)

74ALVC164245

SSOP48: plastic shrink small outline package; 48 leads; body width 7.5 mm

SOT370-1

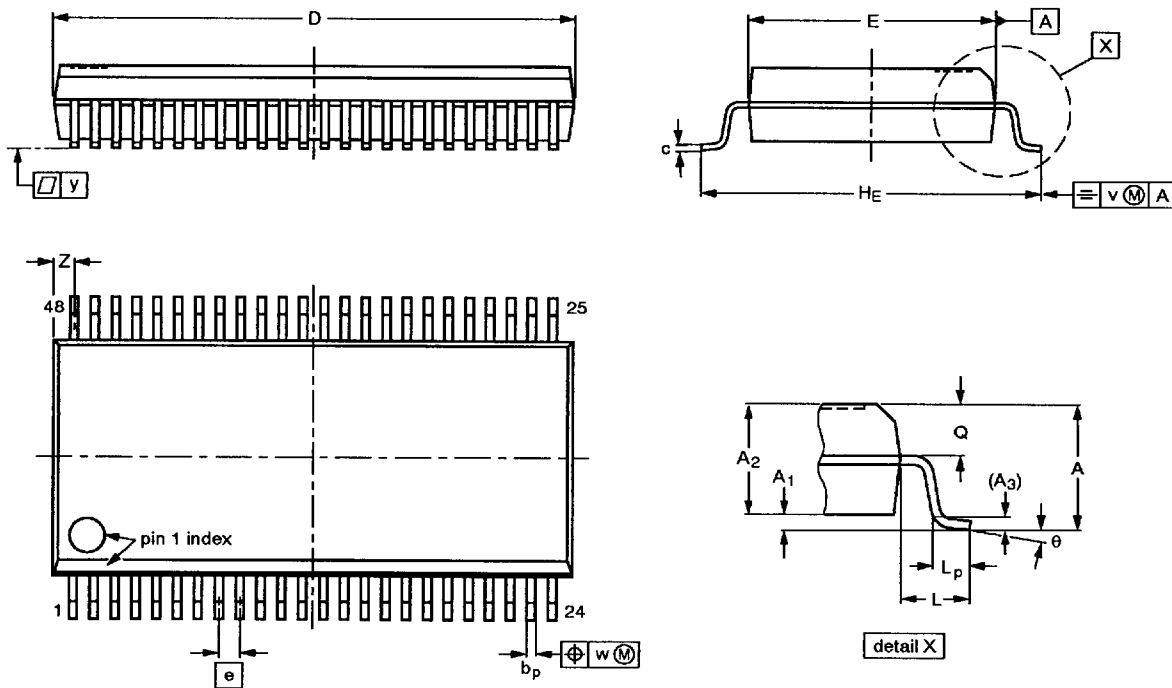

DIMENSIONS (mm are the original dimensions)

UNIT	A max.	A ₁	A ₂	A ₃	b _p	c	D ⁽¹⁾	E ⁽¹⁾	e	H _E	L	L _p	Q	v	w	y	Z ⁽¹⁾	θ
mm	2.8	0.4 0.2	2.35 2.20	0.25	0.3 0.2	0.22 0.13	16.00 15.75	7.6 7.4	0.635	10.4 10.1	1.4	1.0 0.6	1.2 1.0	0.25	0.18	0.1	0.85 0.40	8° 0°

Note

1. Plastic or metal protrusions of 0.25 mm maximum per side are not included.

OUTLINE VERSION	REFERENCES				EUROPEAN PROJECTION	ISSUE DATE
	IEC	JEDEC	EIAJ			
SOT370-1		MO-118AA				93-11-02 95-02-04

16-bit dual supply translating transceiver; (3-State)

74ALVC164245

TSSOP48: plastic thin shrink small outline package; 48 leads; body width 6.1mm

SOT362-1

