



CMSH2-20L
CMSH2-40L

**LOW FORWARD VOLTAGE
SCHOTTKY BARRIER RECTIFIER
2.0 AMP, 20 AND 40 VOLTS**

**Central™
Semiconductor Corp.**

FEATURES:

- LOW FORWARD VOLTAGE DROP
- FLAMMABILITY CLASSIFICATION UL94V-0
- HIGH CURRENT CAPABILITY
- SUPERIOR LOT TO LOT CONSISTENCY
- LOW COST
- "C" BEND CONSTRUCTION PROVIDES STRAIN RELIEF WHEN MOUNTED ON PC BOARD
- HIGH RELIABILITY

**LOW
V_F**



SMB CASE

DESCRIPTION:

The CENTRAL SEMICONDUCTOR 2.0 Amp Surface Mount Low V_F Schottky Rectifier is a high quality, well constructed, highly reliable component designed for use in all types of commercial, industrial, entertainment, computer, and automotive applications where high efficiency is required. To order devices on 12mm Tape and Reel (3000/13" Reel), add TR13 suffix to part number.

MAXIMUM RATINGS: (T_A=25°C unless otherwise noted)

	<u>SYMBOL</u>	<u>CMSH2-20L</u>	<u>CMSH2-40L</u>	
<u>UNITS</u>				
Peak Repetitive Reverse Voltage	V _{RRM}	20	40	V
DC Blocking Voltage	V _R	20	40	V
RMS Reverse Voltage	V _R (RMS)	14	28	V
Average Forward Current(T _L =105°C)	I _O		2.0	A
Peak Forward Surge Current (8.3ms)	I _{FSM}		50	A
Operating and Storage				
Junction Temperature	T _J , T _{stg}		-65 to +150	°C
Thermal Resistance	θ _{JL}		20	°C/W

ELECTRICAL CHARACTERISTICS: (T_A=25°C unless otherwise noted)

<u>SYMBOL</u>	<u>TEST CONDITIONS</u>	<u>MIN</u>	<u>TYP</u>	<u>MAX</u>	<u>UNITS</u>
I _R	V _R =Rated V _{RRM}			0.50	mA
I _R	V _R =Rated V _{RRM} , T _A =100°C			20	mA
V _F	I _F =2.0A (CMSH2-20L)			0.38	V
V _F	I _F =2.0A (CMSH2-40L)			0.40	V
C _J	V _R =4.0V, f=1.0MHz		150		pF

All Dimensions in Inches (mm).

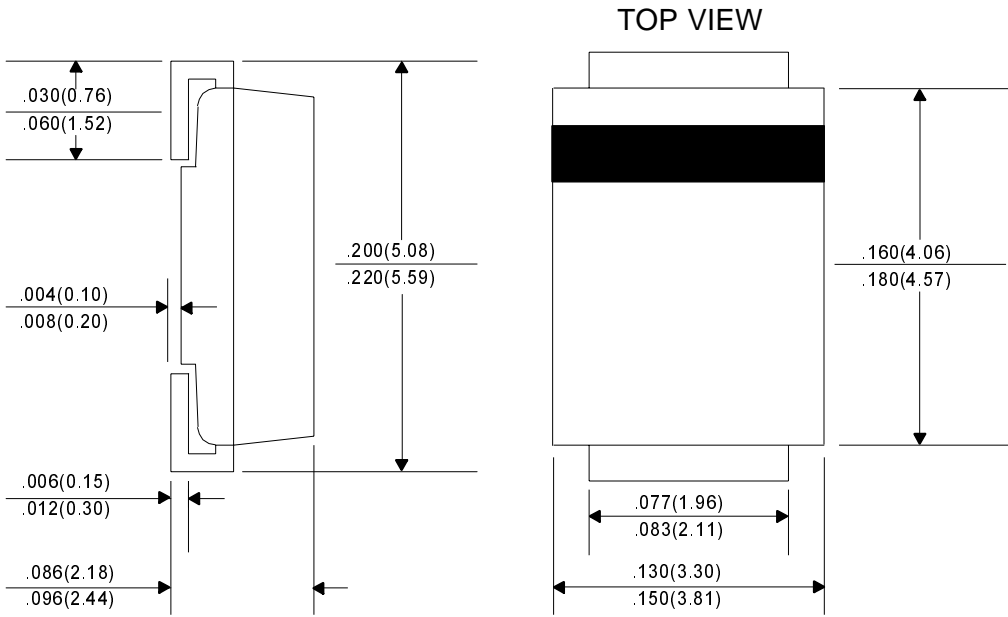

Marking Codes:

DEVICE	MARKING CODE
CMSH2-20L	CS220L
CMSH2-40L	CS240L