

Intellimod™ L-Series Three Phase IGBT Inverter 100 Amperes/1200 Volts

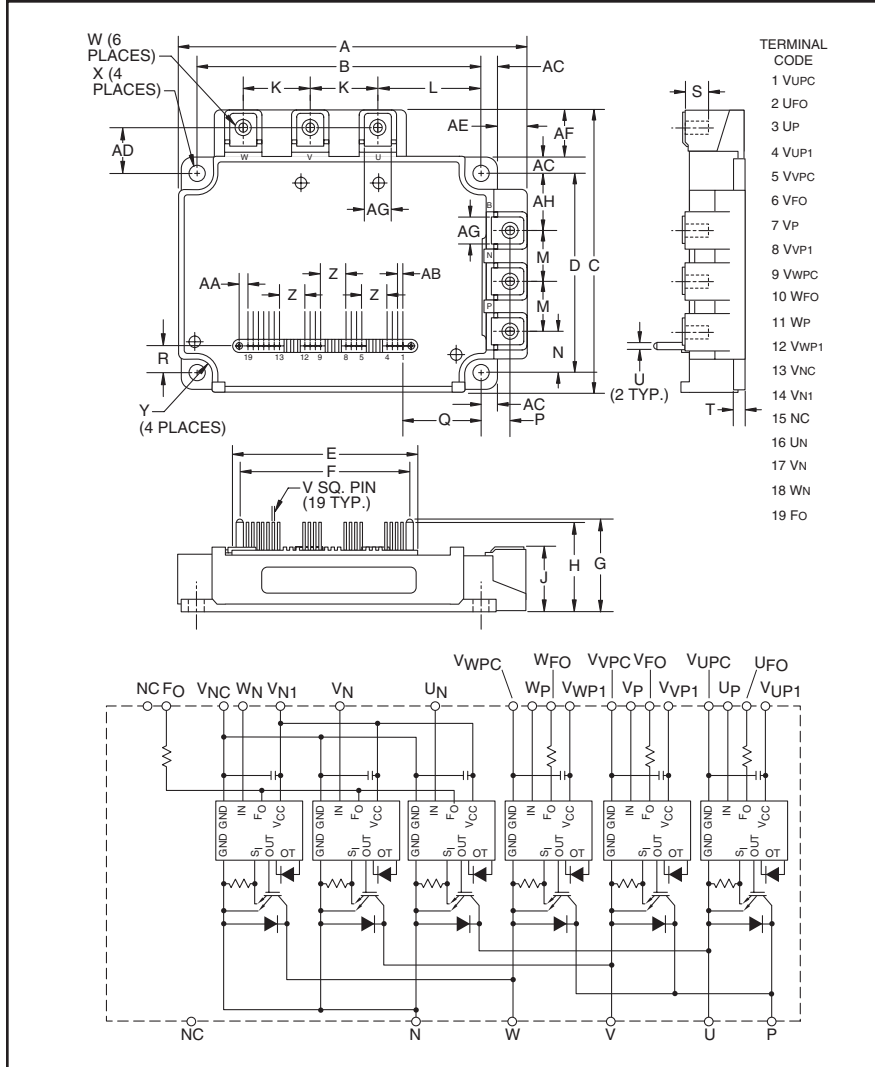

Outline Drawing and Circuit Diagram

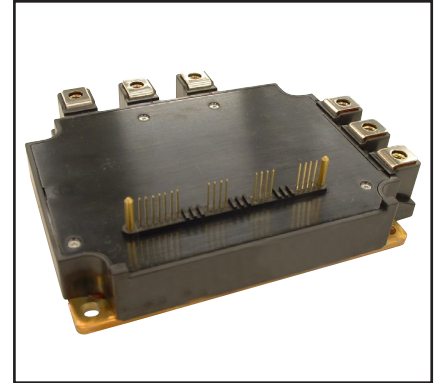

Description:

Powerex Intellimod™ Intelligent Power Modules are isolated base modules designed for power switching applications operating at frequencies to 20kHz. Built-in control circuits provide optimum gate drive and protection for the IGBT and free-wheel diode power devices.

Features:

- Complete Output Power Circuit
- Gate Drive Circuit
- Protection Logic
 - Short Circuit
 - Over Temperature
 - Using On-chip Temperature Sensing
 - Under Voltage
- Low Loss Using 5th Generation IGBT Chip

Applications:

- Inverters
- UPS
- Motion/Servo Control
- Power Supplies

Ordering Information:

Example: Select the complete part number from the table below -i.e. PM100CLA120 is a 1200V, 100 Ampere Intellimod™ Intelligent Power Module.

Dimensions	Inches	Millimeters
A	5.31	135.0
B	4.33±0.02	110±0.5
C	4.33	110.0
D	3.07	78.0±0.5
E	2.81	71.5
F	2.62	66.5
G	1.37	34.7
H	1.32	33.6
J	0.95+0.04/-0.01	24.1+1.0/-0.5
K	1.02	26.0
L	1.59	40.5
M	0.79	20.0
N	0.65	16.5
P	0.43±0.01	11.0±0.3
Q	1.19	30.15
R	0.43	11.0

Dimensions	Inches	Millimeters
S	0.51	13.0
T	0.16	4.0
U	0.1 Dia.	Dia.2.5
V	0.02 Sq.	Sq. 0.5
W	M5 Metric	M5
X	0.22 Dia.	Dia. 5.5
Y	0.24 Rad.	Rad. 6
Z	0.39	10.0
AA	0.13	3.25
AB	0.08	2.0
AC	0.24	6.05
AD	0.71	18.0
AE	0.46	11.7
AF	0.74	18.7
AG	0.41	10.5
AH	0.85	21.5

Type	Current Rating Amperes	V _{CES} Volts (x 10)
PM	100	120

PM100CLA120
Intellimod™ L-Series
Three Phase IGBT Inverter
 100 Amperes/1200 Volts

Absolute Maximum Ratings, $T_j = 25^\circ\text{C}$ unless otherwise specified

Characteristics	Symbol	PM100CLA120	Units
Power Device Junction Temperature	T_j	-20 to 150	$^\circ\text{C}$
Storage Temperature	T_{stg}	-40 to 125	$^\circ\text{C}$
Module Case Operating Temperature (Note 1)	T_C	-20 to 100	$^\circ\text{C}$
Mounting Torque, M5 Mounting Screws	—	31	in-lb
Mounting Torque, M5 Main Terminal Screws	—	31	in-lb
Module Weight (Typical)	—	800	Grams
Supply Voltage, Surge (Applied between P - N)	$V_{\text{CC(surge)}}$	1000	Volts
Self-protection Supply Voltage Limit (Short Circuit protection Capability)*	$V_{\text{CC(prot.)}}$	800	Volts
Isolation Voltage, AC 1 minute, 60Hz Sinusoidal	V_{ISO}	2500	Volts

* $V_D = 13.5 - 16.5\text{V}$, Inverter Part, $T_j = 125^\circ\text{C}$

IGBT Inverter Sector

Collector-Emitter Voltage ($V_D = 15\text{V}$, $V_{\text{CIN}} = 15\text{V}$)	V_{CES}	1200	Volts
Collector Current ($T_C = 25^\circ\text{C}$)	$\pm I_C$	100	Amperes
Peak Collector Current ($T_C = 25^\circ\text{C}$)	$\pm I_{\text{CP}}$	200	Amperes
Collector Dissipation, $T_C = 25^\circ\text{C}$ (Note 1)	P_C	595	Watts

Control Sector

Supply Voltage (Applied between $V_{\text{UP1}}-V_{\text{UPC}}$, $V_{\text{VP1}}-V_{\text{VPC}}$, $V_{\text{WP1}}-V_{\text{WPC}}$, $V_{\text{N1}}-V_{\text{NC}}$)	V_D	20	Volts
Input Voltage (Applied between U_P-V_{UPC} , V_P-V_{VPC} , W_P-V_{WPC} , $U_N-V_N-V_{\text{NC}}$)	V_{CIN}	20	Volts
Fault Output Supply Voltage (Applied between $U_{\text{FO}}-V_{\text{UPC}}$, $V_{\text{FO}}-V_{\text{VPC}}$, $W_{\text{FO}}-V_{\text{WPC}}$, $F_{\text{O}}-V_{\text{NC}}$)	V_{FO}	20	Volts
Fault Output Current (U_{FO} , V_{FO} , W_{FO} , F_{O} Terminals)	I_{FO}	20	mA

Note 1: T_C Baseplate Measurement Point

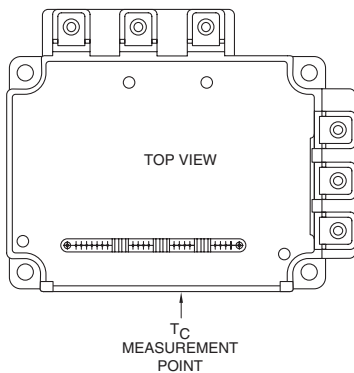

PM100CLA120
Intellimod™ L-Series
Three Phase IGBT Inverter
100 Amperes/1200 Volts

Electrical and Mechanical Characteristics, $T_j = 25^\circ\text{C}$ unless otherwise specified

Characteristics	Symbol	Test Conditions	Min.	Typ.	Max.	Units
IGBT Inverter Sector						
Collector-Emitter Cutoff Current	I_{CES}	$V_{CE} = V_{CES}, V_D = 15V, T_j = 25^\circ\text{C}$	—	—	1.0	mA
		$V_{CE} = V_{CES}, V_D = 15V, T_j = 125^\circ\text{C}$	—	—	10	mA
Diode Forward Voltage	V_{EC}	$-I_C = 100A, V_{CIN} = 15V, V_D = 15V$	—	2.5	3.5	Volts
Collector-Emitter Saturation Voltage	$V_{CE(sat)}$	$V_D = 15V, V_{CIN} = 0V, I_C = 100A, T_j = 25^\circ\text{C}$	—	1.9	—	Volts
		$V_D = 15V, V_{CIN} = 0V, I_C = 100A, T_j = 125^\circ\text{C}$	—	1.9	—	Volts
Inductive Load Switching Times	t_{on}		0.5	1.0	2.5	μs
	t_{rr}	$V_D = 15V, V_{CIN} = 0 \Leftrightarrow 15V$	—	0.15	0.3	μs
	$t_{C(on)}$	$V_{CC} = 600V, I_C = 100A$	—	0.4	1.0	μs
	t_{off}	$T_j = 125^\circ\text{C}$	—	2.0	3.0	μs
	$t_{C(off)}$		—	0.7	1.2	μs

Control Sector

Short Circuit Trip Level	SC	$-20^\circ\text{C} \leq T_j \leq 125^\circ\text{C}, V_D = 15V$	200	—	—	Amperes
Short Circuit Current Delay Time	$t_{off(SC)}$	$V_D = 15V$	—	0.2	—	μs
Over Temperature Protection	OT	Trip Level	135	145	155	$^\circ\text{C}$
(Detect T_j of IGBT Chip)	OT_R	Reset Level	—	125	—	$^\circ\text{C}$
Supply Circuit Under-voltage Protection	UV	Trip Level	11.5	12.0	12.5	Volts
($-20 \leq T_j \leq 125^\circ\text{C}$)	UV_R	Reset Level	—	12.5	—	Volts
Circuit Current	I_D	$V_D = 15V, V_{CIN} = 15V, V_{N1}-V_{NC}$	—	18	28	mA
		$V_D = 15V, V_{CIN} = 15V, V_{XP1}-V_{XPC}$	—	6	12	mA
Input ON Threshold Voltage	$V_{th(on)}$	Applied between U_P-V_{UPC} ,	1.2	1.5	1.8	Volts
Input OFF Threshold Voltage	$V_{th(off)}$	$V_P-V_{VPC}, W_P-V_{WPC}, U_N-V_N, W_N-V_{NC}$	1.7	2.0	2.3	Volts
Fault Output Current*	$I_{FO(H)}$	$V_D = 15V, V_{CIN} = 15V$	—	—	0.01	mA
	$I_{FO(L)}$	$V_D = 15V, V_{CIN} = 15V$	—	10	15	mA
Fault Output Pulse Width*	t_{FO}	$V_D = 15V$	1.0	1.8	—	ms

*Fault output is given only when the internal SC, OT and UV protections schemes of either upper or lower device operate to protect it.



Powerex, Inc., 200 E. Hillis Street, Youngwood, Pennsylvania 15697-1800 (724) 925-7272

PM100CLA120
Intellimod™ L-Series
Three Phase IGBT Inverter
100 Amperes/1200 Volts

Electrical and Mechanical Characteristics, $T_j = 25^\circ\text{C}$ unless otherwise specified

Characteristics	Symbol	Test Conditions	Min.	Typ.	Max.	Units
-----------------	--------	-----------------	------	------	------	-------

Thermal Characteristics

Characteristic	Symbol	Condition	Min.	Typ.	Max.	Units
Junction to Case Thermal Resistance	$R_{th(j-c)Q}$	IGBT (Per 1/6 Module) (Note 1)	—	—	0.21	$^\circ\text{C/Watt}$
	$R_{th(j-c)D}$	FWDi (Per 1/6 Module) (Note 1)	—	—	0.34	$^\circ\text{C/Watt}$
	$R_{th(j-c)Q}$	IGBT (Per 1/6 Module) (Note 2)	—	—	0.16*	$^\circ\text{C/Watt}$
	$R_{th(j-c)D}$	FWDi (Per 1/6 Module) (Note 2)	—	—	0.26*	$^\circ\text{C/Watt}$
Contact Thermal Resistance	$R_{th(c-f)}$	Case to Fin Per Module, Thermal Grease Applied	—	—	0.023	$^\circ\text{C/Watt}$

* If you use this value, $R_{th(f-a)}$ should be measured just under the chips.
 Note 2: T_C measurement point is just under the chip.

Recommended Conditions for Use

Characteristic	Symbol	Condition	Value	Units
Supply Voltage	V_{CC}	Applied across P-N Terminals	≤ 800	Volts
Control Supply Voltage**	V_D	Applied between V_{UP1} - V_{UPC} , V_{VP1} - V_{VPC} , V_{WP1} - V_{WPC} , V_{N1} - V_{NC}	15.0 ± 1.5	Volts
Input ON Voltage	$V_{CIN(on)}$	Applied between U_P - V_{UPC} ,	≤ 0.8	Volts
Input OFF Voltage	$V_{CIN(off)}$	V_P - V_{VPC} , W_P - V_{WPC} , U_N - V_N - W_N - V_{NC}	≥ 9.0	Volts
PWM Input Frequency	f_{PWM}		≤ 20	kHz
Arm Shoot-through Blocking Time	t_{DEAD}	Input Signal	≥ 2.5	μs

***With ripple satisfying the following conditions: dv/dt swing $\leq \pm 5V/\mu\text{s}$, Variation $\leq 2V$ peak to peak.