

3.3V Quad buffer (3-State)

74LVT125

FEATURES

- Quad bus interface
- 3-State buffers
- Output capability: +64mA/-32mA
- TTL input and output switching levels
- Input and output interface capability to systems at 5V supply
- Bus-hold data inputs eliminate the need for external pull-up resistors to hold unused inputs
- Live insertion/extraction permitted
- No bus current loading when output is tied to 5V bus
- Power-up 3-State
- Latch-up protection exceeds 500mA per JEDEC Std 17
- ESD protection exceeds 2000V per MIL STD 883 Method 3015 and 200V per Machine Model

DESCRIPTION

The LVT125 is a high-performance BiCMOS product designed for V_{CC} operation at 3.3V.

This device combines low static and dynamic power dissipation with high speed and high output drive.

The 74LVT125 device is a quad buffer that is ideal for driving bus lines. The device features four Output Enables ($\overline{OE}0$, $\overline{OE}1$, $\overline{OE}2$, $\overline{OE}3$), each controlling one of the 3-State outputs.

QUICK REFERENCE DATA

SYMBOL	PARAMETER	CONDITIONS $T_{amb} = 25^{\circ}C$; $GND = 0V$	TYPICAL	UNIT
t_{PLH} t_{PHL}	Propagation delay A_n to Y_n	$C_L = 50pF$; $V_{CC} = 3.3V$	2.7 2.9	ns
C_{IN}	Input capacitance	$V_I = 0V$ or $3.0V$	4	pF
C_{OUT}	Output capacitance	Outputs disabled; $V_O = 0V$ or $3.0V$	8	pF
I_{CCZ}	Total supply current	Outputs disabled; $V_{CC} = 3.6V$	0.13	mA

ORDERING INFORMATION

PACKAGES	TEMPERATURE RANGE	OUTSIDE NORTH AMERICA	NORTH AMERICA	DWG NUMBER
14-Pin Plastic SO	-40°C to +85°C	74LVT125 D	74LVT125 D	SOT108-1
14-Pin Plastic SSOP	-40°C to +85°C	74LVT125 DB	74LVT125 DB	SOT337-1
14-Pin Plastic TSSOP	-40°C to +85°C	74LVT125 PW	74LVT125PW DH	SOT402-1

PIN CONFIGURATION

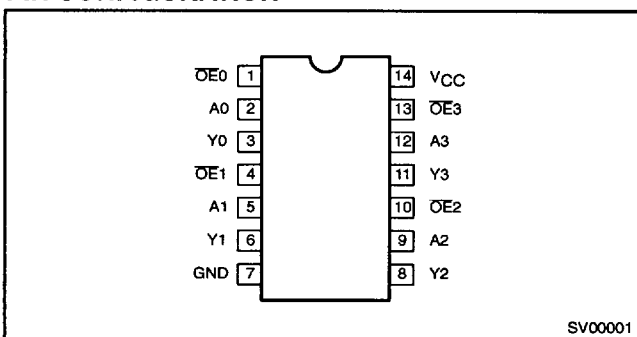

LOGIC SYMBOL

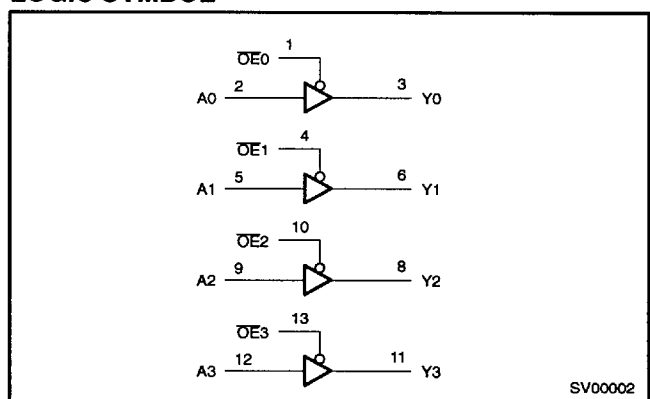

3.3V Quad buffer (3-State)

74LVT125

LOGIC SYMBOL (IEEE/IEC)

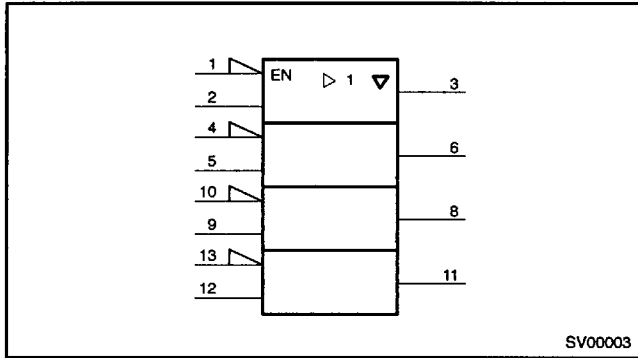

FUNCTION TABLE (EACH BUFFER)

INPUTS		OUTPUTS
$\overline{OE}n$	A_n	Y_n
L	L	L
L	H	H
H	X	Z

H = High voltage level
 L = Low voltage level
 X = Don't care
 Z = High impedance "Off" state

PIN DESCRIPTION

PIN NUMBER	SYMBOL	NAME AND FUNCTION
2, 5, 9, 12	$A_0 - A_3$	Data inputs
3, 6, 8, 11	$Y_0 - Y_3$	Data outputs
1, 4, 10, 13	$\overline{OE}0 - \overline{OE}3$	Output enables
7	GND	Ground (0V)
14	V_{CC}	Positive supply voltage

ABSOLUTE MAXIMUM RATINGS^{1, 2}

SYMBOL	PARAMETER	CONDITIONS	RATING	UNIT
V_{CC}	DC supply voltage		-0.5 to +4.6	V
V_I	DC input voltage ³		-0.5 to +7.0	V
V_{OUT}	DC output voltage ³	Output in Off or High state	-0.5 to +7.0	V
I_{OUT}	DC output current	Output in Low state	128	mA
		Out in High State	-64	mA
I_{IK}	DC input diode current	$V_I < 0$	-50	mA
I_{OK}	DC output diode current	$V_O < 0$	-50	mA
T_{stg}	Storage temperature range		-65 to 150	°C

NOTES:

- Stresses beyond those listed may cause permanent damage to the device. These are stress ratings only and functional operation of the device at these or any other conditions beyond those indicated under "recommended operating conditions" is not implied. Exposure to absolute-maximum-rated conditions for extended periods may affect device reliability.
- The performance capability of a high-performance integrated circuit in conjunction with its thermal environment can create junction temperatures which are detrimental to reliability. The maximum junction temperature of this integrated circuit should not exceed 150°C.
- The input and output negative voltage ratings may be exceeded if the input and output clamp current ratings are observed.

3.3V Quad buffer (3-State)

74LVT125

RECOMMENDED OPERATING CONDITIONS

SYMBOL	PARAMETER	LIMITS		UNIT
		MIN	MAX	
V _{CC}	DC supply voltage	2.7	3.6	V
V _I	Input voltage	0	5.5	V
V _{IH}	High-level input voltage	2.0		V
V _{IL}	Low-level input voltage		0.8	V
I _{OH}	High-level output current		-32	mA
I _{OL}	Low-level output current		32	mA
	Low-level output current; current duty cycle ≤ 50%, f ≥ 1kHz		64	
Δt/Δv	Input transition rise or fall rate; outputs enabled		10	ns/V
T _{amb}	Operating free-air temperature range	-40	+85	°C

DC ELECTRICAL CHARACTERISTICS

SYMBOL	PARAMETER	TEST CONDITIONS	LIMITS			UNIT
			Temp = -40°C to +85°C			
			MIN	TYP ¹	MAX	
V _{IK}	Input clamp voltage	V _{CC} = 2.7V; I _{IK} = -18mA		-0.9	-1.2	V
V _{OH}	High-level output voltage	V _{CC} = 2.7 to 3.6V; I _{OH} = -100μA	V _{CC} -0.2	V _{CC} -0.1		V
		V _{CC} = 2.7V; I _{OH} = -8mA	2.4	2.5		
		V _{CC} = 3.0V; I _{OH} = -32mA	2.0	2.2		
V _{OL}	Low-level output voltage	V _{CC} = 2.7V; I _{OL} = 100μA		0.1	0.2	V
		V _{CC} = 2.7V; I _{OL} = 24mA		0.3	0.5	
		V _{CC} = 3.0V; I _{OL} = 16mA		0.25	0.4	
		V _{CC} = 3.0V; I _{OL} = 32mA		0.3	0.5	
		V _{CC} = 3.0V; I _{OL} = 64mA		0.4	0.55	
I _I	Input leakage current	V _{CC} = 0 or 3.6V; V _I = 5.5V	All inputs	1	10	μA
		V _{CC} = 3.6V; V _I = V _{CC} or GND	Control pins	±0.1	±1	
		V _{CC} = 3.6V; V _I = V _{CC}	Data pins ⁴	0.1	1	
		V _{CC} = 3.6V; V _I = 0		-1	-5	
I _{OFF}	Output off current	V _{CC} = 0V; V _I or V _O = 0 to 4.5V		1	±100	μA
I _{HOLD}	Bus Hold current A inputs	V _{CC} = 3V; V _I = 0.8V	75	150		μA
		V _{CC} = 3V; V _I = 2.0V	-75	-150		μA
I _{EX}	Current into an output in the High state when V _O > V _{CC}	V _O = 5.5V; V _{CC} = 3.0V		60	125	μA
I _{PU/PD}	Power up/down 3-State output current ³	V _{CC} ≤ 1.2V; V _O = 0.5V to V _{CC} ; V _I = GND or V _{CC} ; OE/OE = Don't care		±1	±100	μA
I _{OZH}	3-State output high current	V _{CC} = 3.6V; V _O = 3.0V		1	5	μA
I _{OZL}	3-State output low current	V _{CC} = 3.6V; V _O = 0.5V		-1	-5	μA
I _{CCH}	Quiescent supply current	V _{CC} = 3.6V; Outputs High, V _I = GND or V _{CC} , I _O = 0		0.13	0.19	mA
I _{CCL}		V _{CC} = 3.6V; Outputs Low, V _I = GND or V _{CC} , I _O = 0		2	7	
I _{CCZ}		V _{CC} = 3.6V; Outputs Disabled; V _I = GND or V _{CC} , I _O = 0 ⁵		0.13	0.19	
ΔI _{CC}	Additional supply current per input pin ²	V _{CC} = 3V to 3.6V; One input at V _{CC} -0.6V, Other inputs at V _{CC} or GND		0.1	0.2	mA

NOTES:

1. All typical values are at V_{CC} = 3.3V and T_{amb} = 25°C.
2. This is the increase in supply current for each input at the specified voltage level other than V_{CC} or GND
3. This parameter is valid for any V_{CC} between 0V and 1.2V with a transition time of up to 10msec. From V_{CC} = 1.2V to V_{CC} = 3.3V ± 0.3V a transition time of 100μsec is permitted. This parameter is valid for T_{amb} = 25°C only.
4. Unused pins at V_{CC} or GND.
5. I_{CCZ} is measured with outputs pulled to V_{CC} or GND.

3.3V Quad buffer (3-State)

74LVT125

AC CHARACTERISTICS

GND = 0V; $t_R = t_F = 2.5\text{ns}$; $C_L = 50\text{pF}$; $R_L = 500\Omega$; $T_{\text{amb}} = -40^\circ\text{C}$ to $+85^\circ\text{C}$.

SYMBOL	PARAMETER	WAVEFORM	LIMITS				UNIT
			$V_{CC} = 3.3V \pm 0.3V$			$V_{CC} = 2.7V$	
			MIN	TYP ¹	MAX	MAX	
t_{PLH} t_{PHL}	Propagation delay An to Yn	1	1.0 1.0	2.7 2.9	4.0 3.9	4.5 4.9	ns
t_{PZH} t_{PZL}	Output enable time $\overline{OE}n$ to Yn	2	1.0 1.1	3.4 3.4	4.7 4.7	6.0 6.5	ns
t_{PHZ} t_{PLZ}	Output disable time $\overline{OE}n$ to Yn	2	1.8 1.3	3.7 2.6	5.1 4.5	5.7 4.0	ns

NOTE:

1. All typical values are at $V_{CC} = 3.3V$ and $T_{\text{amb}} = 25^\circ\text{C}$.

AC WAVEFORMS

$V_M = 1.5V$, $V_{IN} = \text{GND}$ to $2.7V$

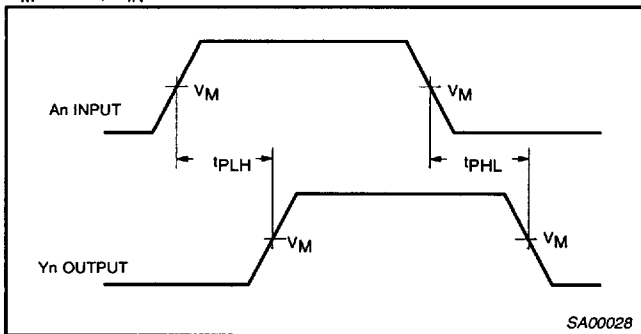

Waveform 1. Waveforms Showing the Input (An) to Output (Yn) Propagation Delays

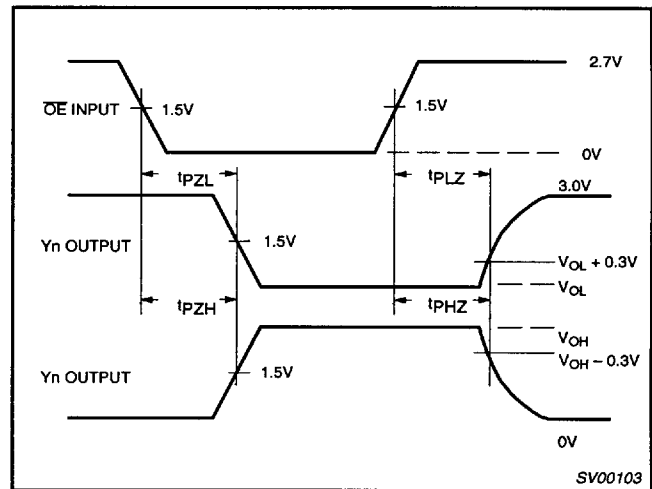

Waveform 2. Waveforms Showing the 3-State Output Enable and Disable Times

3.3V Quad buffer (3-State)

74LVT125

TEST CIRCUIT AND WAVEFORMS

Test Circuit for 3-State Outputs

$V_M = 1.5V$
Input Pulse Definition

SWITCH POSITION

TEST	SWITCH
t_{PLH}/t_{PHL}	Open
t_{PLZ}/t_{PZL}	6V
t_{PHZ}/t_{PZH}	GND

DEFINITIONS

R_L = Load resistor; see AC CHARACTERISTICS for value.

C_L = Load capacitance includes jig and probe capacitance; see AC CHARACTERISTICS for value.

R_T = Termination resistance should be equal to Z_{OUT} of pulse generators.

FAMILY	INPUT PULSE REQUIREMENTS				
	Amplitude	Rep. Rate	t_w	t_R	t_F
74LVT	2.7V	$\leq 10MHz$	500ns	$\leq 2.5ns$	$\leq 2.5ns$

SV00092

3.3V Quad buffer (3-State)

74LVT125

SO14: plastic small outline package; 14 leads; body width 3.9 mm

SOT108-1

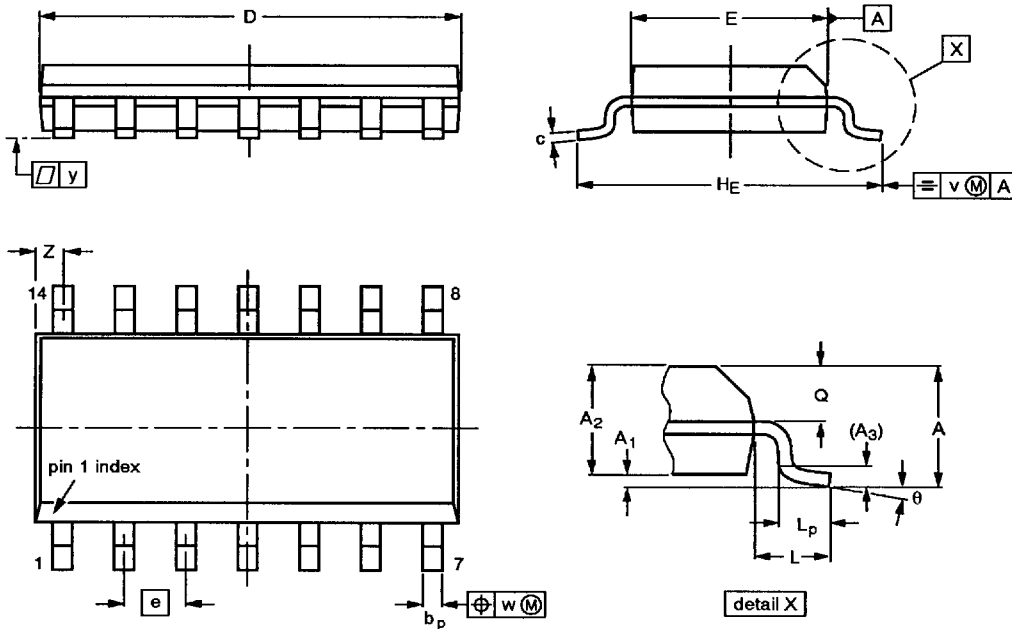

DIMENSIONS (inch dimensions are derived from the original mm dimensions)

UNIT	A max.	A ₁	A ₂	A ₃	b _p	c	D ⁽¹⁾	E ⁽¹⁾	e	H _E	L	L _p	Q	v	w	y	z ⁽¹⁾	θ
mm	1.75	0.25 0.10	1.45 1.25	0.25	0.49 0.36	0.25 0.19	8.75 8.55	4.0 3.8	1.27	6.2 5.8	1.05	1.0 0.4	0.7 0.6	0.25	0.25	0.1	0.7 0.3	8° 0°
inches	0.069	0.0098 0.0039	0.057 0.049	0.01	0.019 0.014	0.0098 0.0075	0.35 0.34	0.16 0.15	0.050	0.24 0.23	0.041	0.039 0.016	0.028 0.024	0.01	0.01	0.004	0.028 0.012	

Note

1. Plastic or metal protrusions of 0.15 mm maximum per side are not included.

OUTLINE VERSION	REFERENCES				EUROPEAN PROJECTION	ISSUE DATE
	IEC	JEDEC	EIAJ			
SOT108-1	076E06S	MS-012AB				91-08-13 95-01-23

3.3V Quad buffer (3-State)

74LVT125

SSOP14: plastic shrink small outline package; 14 leads; body width 5.3 mm

SOT337-1

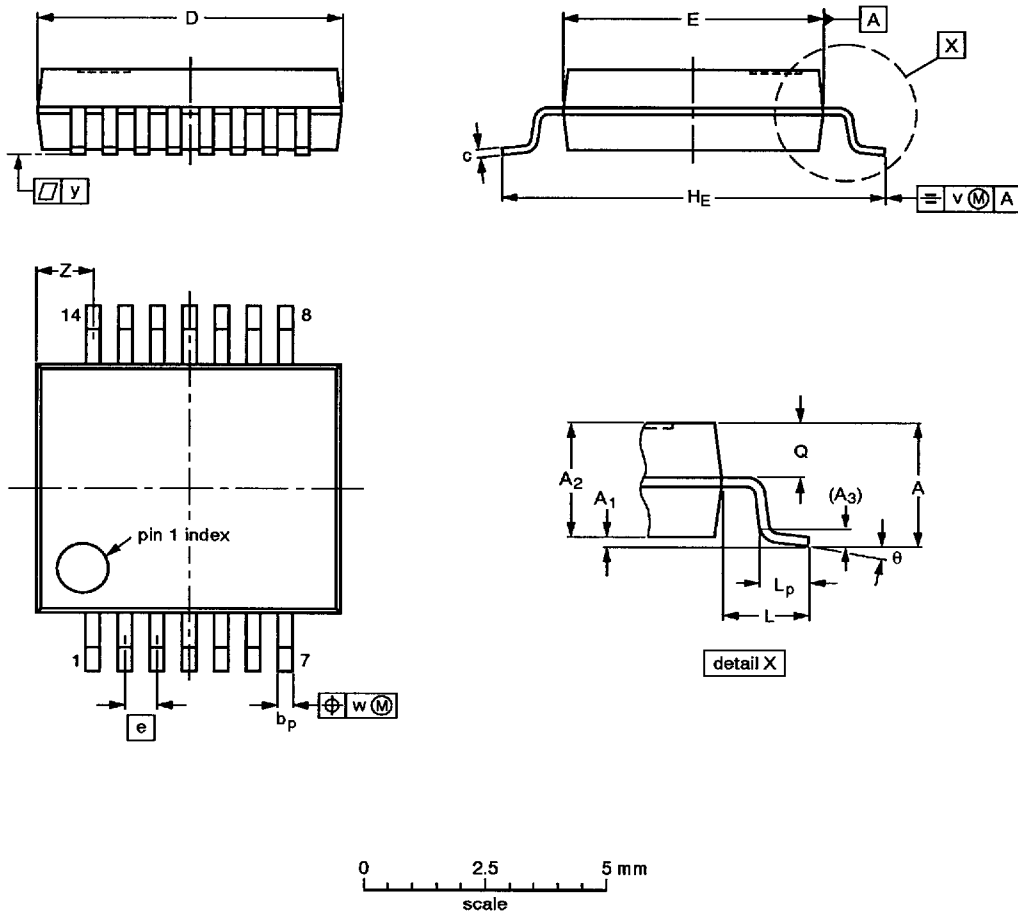

DIMENSIONS (mm are the original dimensions)

UNIT	A max.	A ₁	A ₂	A ₃	b _p	c	D ⁽¹⁾	E ⁽¹⁾	e	H _E	L	L _p	Q	v	w	y	Z ⁽¹⁾	θ
mm	2.0	0.21 0.05	1.80 1.65	0.25	0.38 0.25	0.20 0.09	6.4 6.0	5.4 5.2	0.65	7.9 7.6	1.25	1.03 0.63	0.9 0.7	0.2	0.13	0.1	1.4 0.9	8° 0°

Note

1. Plastic or metal protrusions of 0.25 mm maximum per side are not included.

OUTLINE VERSION	REFERENCES				EUROPEAN PROJECTION	ISSUE DATE
	IEC	JEDEC	EIAJ			
SOT337-1		MO-150AB				94-01-14 95-02-04

3.3V Quad buffer (3-State)

74LVT125

TSSOP14: plastic thin shrink small outline package; 14 leads; body width 4.4 mm

SOT402-1

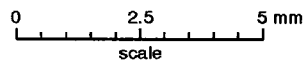
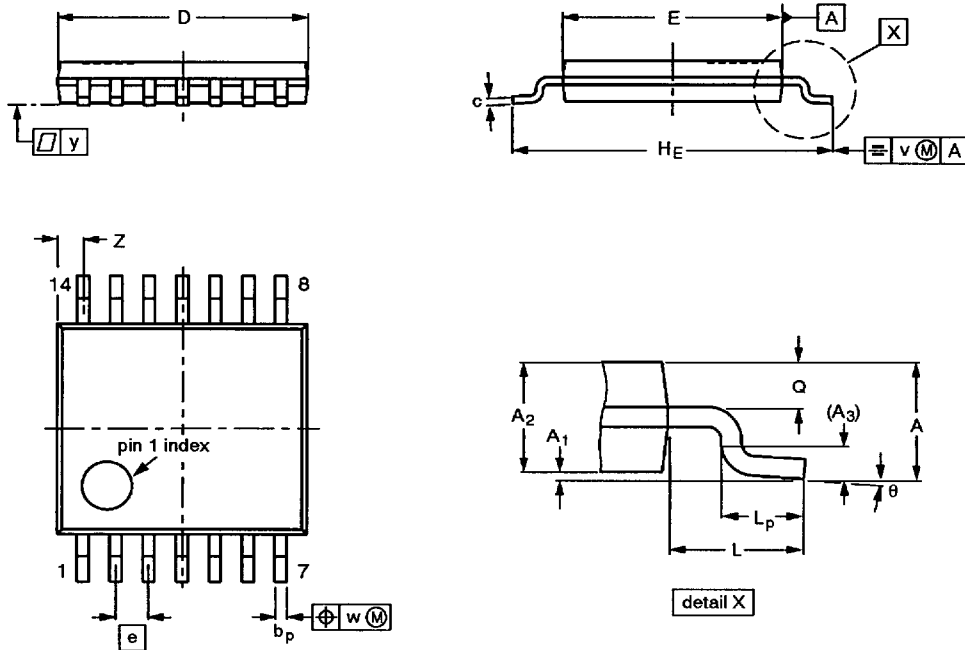

DIMENSIONS (mm are the original dimensions)

UNIT	A max.	A ₁	A ₂	A ₃	b _p	c	D ⁽¹⁾	E ⁽²⁾	e	H _E	L	L _p	Q	v	w	y	z ⁽¹⁾	θ
mm	1.10	0.15 0.05	0.95 0.80	0.25	0.30 0.19	0.2 0.1	5.1 4.9	4.5 4.3	0.65	6.6 6.2	1.0	0.75 0.50	0.4 0.3	0.2	0.13	0.1	0.72 0.38	8° 0°

Notes

1. Plastic or metal protrusions of 0.15 mm maximum per side are not included.
2. Plastic interlead protrusions of 0.25 mm maximum per side are not included.

OUTLINE VERSION	REFERENCES				EUROPEAN PROJECTION	ISSUE DATE
	IEC	JEDEC	EIAJ			
SOT402-1		MO-153				94-07-12- 95-04-04