

# LM111, LM211, LM311, LM311Y DIFFERENTIAL COMPARATORS WITH STROBES

SLCS007A – SEPTEMBER 1973 – REVISED FEBRUARY 1992

- **Fast Response Times**
- **Strobe Capability**
- **Maximum Input Bias Current . . . 300 nA**
- **Maximum Input Offset Current . . . 70 nA**
- **Can Operate From Single 5-V Supply**
- **Designed to Be Interchangeable With National Semiconductor LM111, LM211, and LM311**

## description

The LM111, LM211, and LM311 are single high-speed voltage comparators. These devices are designed to operate from a wide range of power supply voltages, including  $\pm 15$ -V supplies for operational amplifiers and 5-V supplies for logic systems. The output levels are compatible with most TTL and MOS circuits. These comparators are capable of driving lamps or relays and switching voltages up to 50 V at 50 mA. All inputs and outputs can be isolated from system ground. The outputs can drive loads referenced to ground,  $V_{CC+}$  or  $V_{CC-}$ . Offset balancing and strobe capabilities are available, and the outputs can be wire-OR connected. If the strobe is low, the output will be in the off state regardless of the differential input.

The LM111 is characterized for operation over the full military range of  $-55^{\circ}\text{C}$  to  $125^{\circ}\text{C}$ . The LM211 is characterized for operation from  $-40^{\circ}\text{C}$  to  $85^{\circ}\text{C}$ , and the LM311 is characterized for operation from  $0^{\circ}\text{C}$  to  $70^{\circ}\text{C}$ .

## functional block diagram

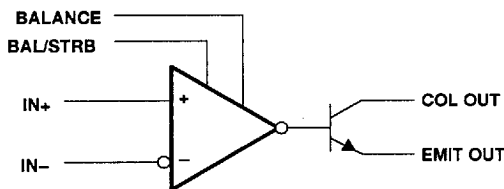

LM111 . . . J PACKAGE

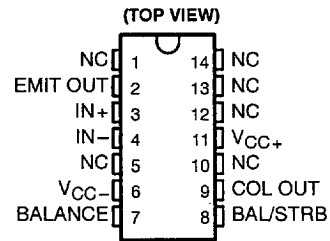

LM111 . . . JG PACKAGE  
LM211, LM311 . . . D, DB, P, OR PW PACKAGE

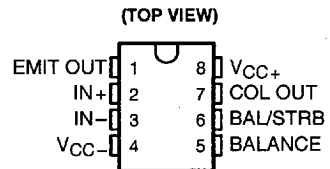

LM111 . . . U PACKAGE

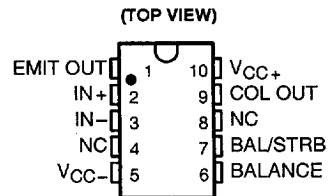

LM111 . . . FK PACKAGE

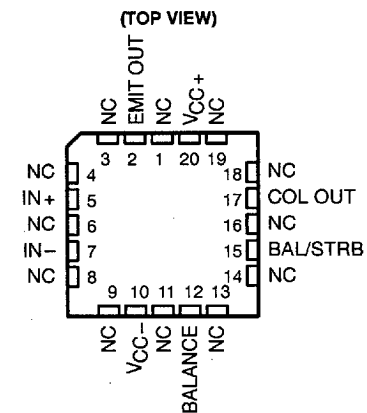

NC – No internal connection

 **TEXAS  
INSTRUMENTS**

POST OFFICE BOX 655303 • DALLAS, TEXAS 75265

Copyright © 1992, Texas Instruments Incorporated

8961724 0094785 73T

6-3

# LM111, LM211, LM311, LM311Y DIFFERENTIAL COMPARATORS WITH STROBES

SLCS007A - SEPTEMBER 1973 - REVISED FEBRUARY 1992

## AVAILABLE OPTIONS

T <sub>A</sub>	V <sub>IOMAX</sub> at 25°C	PACKAGED DEVICES								CHIP FORM (Y)
		SMALL OUTLINE (D)†	SSOP (DB)	CHIP CARRIER (FK)	CERAMIC DIP (J)	CERAMIC DIP (JG)	PLASTIC DIP (P)	TSSOP (PW)	FLATPACK (U)	
0°C to 70°C	7.5 mV	LM311D	LM311DBLE				LM311P	LM311PWLE		LM311Y
-40°C to 85°C	3 mV	LM211D					LM211P			
-55°C to 125°C	3 mV			LM111FK	LM111J	LM111JG			LM111U	

† The D package is available taped and reeled. Add the suffix R (e.g., LM311DR). The DB and PW packages are only available left-end taped and reeled.

## schematic

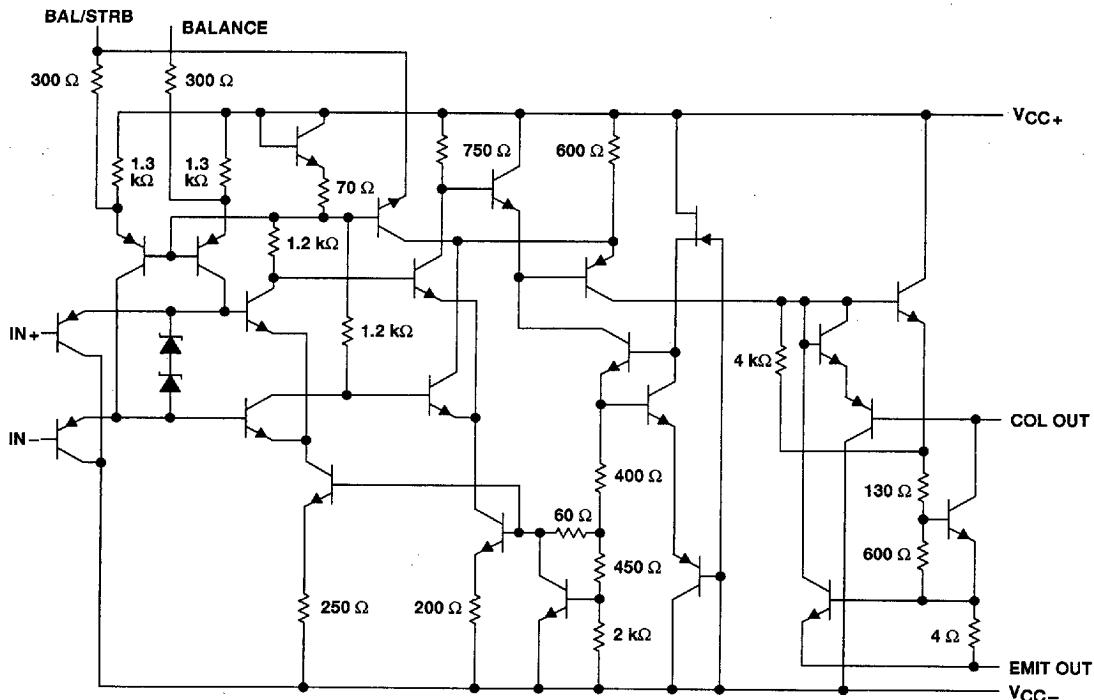

Component Count	
Resistors	20
Diodes	2
Epifet	1
Transistors	22

All resistor values shown are nominal.

8961724 0094786 676

 **TEXAS  
INSTRUMENTS**

POST OFFICE BOX 655303 • DALLAS, TEXAS 75265

# LM111, LM211, LM311, LM311Y DIFFERENTIAL COMPARATORS WITH STROBES

SLCS007A - SEPTEMBER 1973 - REVISED FEBRUARY 1992

## LM311Y chip information

This chip, when properly assembled, displays characteristics similar to the LM311. Thermal compression or ultrasonic bonding may be used on the doped-aluminum bonding pads. Chips may be mounted with conductive epoxy or a gold-silicon preform.

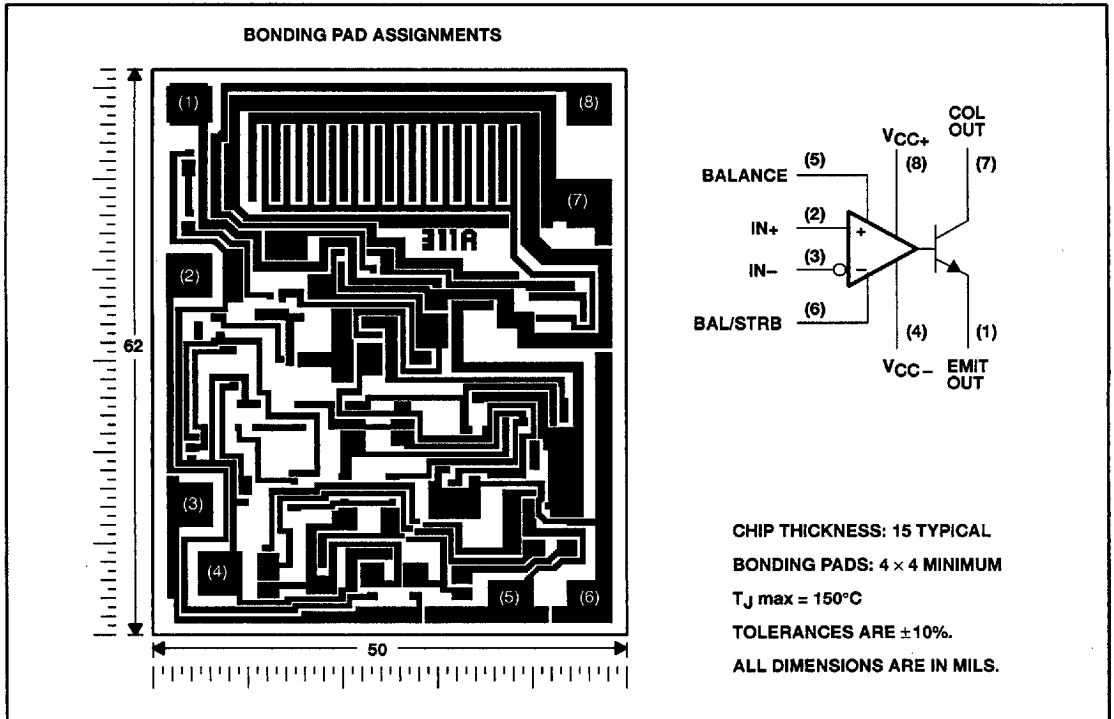

8961724 0094787 502

**TEXAS  
INSTRUMENTS**

POST OFFICE BOX 655303 • DALLAS, TEXAS 75265

6-5

# LM111, LM211, LM311, LM311Y DIFFERENTIAL COMPARATORS WITH STROBES

SLCS007A – SEPTEMBER 1973 – REVISED FEBRUARY 1992

## absolute maximum ratings over operating free-air temperature range (unless otherwise noted)†

Supply voltage, $V_{CC+}$ (see Note 1)	18 V
Supply voltage, $V_{CC-}$ (see Note 1)	-18 V
Supply voltage, $V_{CC+} - V_{CC-}$	36 V
Differential input voltage, $V_{ID}$ (see Note 2)	$\pm 30$ V
Input voltage, $V_I$ (either input, see Notes 1 and 3)	$\pm 15$ V
Voltage from emitter output to $V_{CC-}$	30 V
Voltage from collector output to $V_{CC-}$ :	
LM111	50 V
LM211	50 V
LM311	40 V
Duration of output short circuit (see Note 4)	10 s
Continuous total dissipation	See Dissipation Rating Table
Operating free-air temperature range, $T_A$ :	
LM111	-55°C to 125°C
LM211	-40°C to 85°C
LM311	0°C to 70°C
Storage temperature range	-65°C to 150°C
Case temperature for 60 seconds: FK package	260°C
Lead temperature 1,6 mm (1/16 inch) from case for 10 seconds: J, JG, or U package	300°C
Lead temperature 1,6 mm (1/16 inch) from case for 60 seconds: D, DB, P, or PW package	260°C

† Stresses beyond those listed under "absolute maximum ratings" may cause permanent damage to the device. These are stress ratings only, and functional operation of the device at these or any other conditions beyond those indicated under "recommended operating conditions" is not implied. Exposure to absolute-maximum-rated conditions for extended periods may affect device reliability.

NOTES: 1. All voltage values, unless otherwise noted, are with respect to the midpoint between  $V_{CC+}$  and  $V_{CC-}$ .

2. Differential voltages are at  $IN+$  with respect to  $IN-$ .

3. The magnitude of the input voltage must never exceed the magnitude of the supply voltage or  $\pm 15$  V, whichever is less.

4. The output may be shorted to ground or either power supply.

DISSIPATION RATING TABLE

PACKAGE	$T_A \leq 25^\circ\text{C}$ POWER RATING	DERATING FACTOR	DERATE ABOVE $T_A$	$T_A = 70^\circ\text{C}$ POWER RATING	$T_A = 85^\circ\text{C}$ POWER RATING	$T_A = 125^\circ\text{C}$ POWER RATING
D	500 mW	5.8 mW/°C	64°C	464 mW	377 mW	-
DB or PW	500 mW	4.2 mW/°C	31°C	336 mW	-	-
FK	500 mW	11.0 mW/°C	105°C	500 mW	500 mW	275 mW
J	500 mW	11.0 mW/°C	105°C	500 mW	500 mW	275 mW
JG	500 mW	8.4 mW/°C	90°C	500 mW	500 mW	210 mW
P	500 mW	8.0 mW/°C	88°C	500 mW	500 mW	-
U	500 mW	5.4 mW/°C	57°C	432 mW	351 mW	135 mW

## recommended operating conditions

	MIN	MAX	UNIT
Supply voltage, $V_{CC+} - V_{CC-}$	3.5	30	V
Input voltage ( $ V_{CC\pm}  \leq 15$ V)	$V_{CC-} + 0.5$	$V_{CC+} - 1.5$	V
Operating free-air temperature range, $T_A$	LM111	-55	125
	LM211	-40	85
	LM311	0	70
			°C

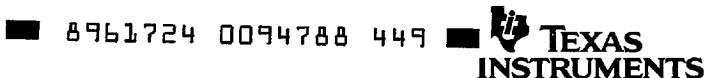

# LM111, LM211, LM311, LM311Y DIFFERENTIAL COMPARATORS WITH STROBES

SLCS007A - SEPTEMBER 1973 - REVISED FEBRUARY 1992

## electrical characteristics at specified free-air temperature, $V_{CC\pm} = \pm 15\text{ V}$ (unless otherwise noted)

PARAMETER	TEST CONDITIONS	$T_A$ †	LM111, LM211			LM311			UNIT
			MIN	TYP‡	MAX	MIN	TYP‡	MAX	
$V_{IO}$ Input offset voltage	See Note 5	25°C	0.7 3			2 7.5			mV
		Full range	4			10			
$I_{IO}$ Input offset current	See Note 5	25°C	4 10			6 50			nA
		Full range	20			70			
$I_{IB}$ Input bias current	$V_O = 1\text{ V to }14\text{ V}$	25°C	75 100			100 250			nA
		Full range	150			300			
$I_{IL(S)}$ Low-level strobe current (see Note 6)	$V_{(strobe)} = 0.3\text{ V}, V_{ID} \leq -10\text{ mV}$	25°C	-3			-3			mA
$V_{ICR}$ Common-mode input voltage range		Full range	13 to -14.5	13.8 to -14.7		13 to -14.5	13.8 to -14.7	V	
$A_{VD}$ Large-signal differential voltage amplification	$V_O = 5\text{ V to }35\text{ V}, R_L = 1\text{ k}\Omega$	25°C	40 200			40 200			V/mV
$I_{OH}$ High-level (collector) output current	$I_{(strobe)} = -3\text{ mA}, V_{ID} = 5\text{ mV}, V_{OH} = 35\text{ V}$	25°C	0.2 10						nA
		Full range	0.5						$\mu\text{A}$
$V_{OL}$ Low-level (collector-to-emitter) output voltage	$I_{OL} = 50\text{ mA}$	$V_{ID} = -5\text{ mV}$	25°C 0.75 1.5						V
		$V_{ID} = -10\text{ mV}$	25°C			0.75 1.5			
	$V_{CC+} = 4.5\text{ V}, V_{CC-} = 0, I_{OL} = 8\text{ mA}$	$V_{ID} = -6\text{ mV}$	Full range 0.23 0.4						
		$V_{ID} = -10\text{ mV}$	Full range			0.23 0.4			
$I_{CC+}$ Supply current from $V_{CC+}$ , output low	$V_{ID} = -10\text{ mV},$ No load	25°C	5.1 6			5.1 7.5			mA
$I_{CC-}$ Supply current from $V_{CC-}$ , output high	$V_{ID} = 10\text{ mV},$ No load	25°C	-4.1 -5			-4.1 -5			mA

† Unless otherwise noted, all characteristics are measured with BALANCE and BAL/STRB open and the emitter output grounded.

Full range for LM111 is  $-55^\circ\text{C}$  to  $125^\circ\text{C}$ , for LM211 is  $-40^\circ\text{C}$  to  $85^\circ\text{C}$ , and for LM311 is  $0^\circ\text{C}$  to  $70^\circ\text{C}$ .

‡ All typical values are at  $T_A = 25^\circ\text{C}$ .

NOTES: 5. The offset voltages and offset currents given are the maximum values required to drive the collector output up to 14 V or down to 1 V with a pullup resistor of  $7.5\text{ k}\Omega$  to  $V_{CC+}$ . These parameters actually define an error band and take into account the worst-case effects of voltage gain and input impedance.

6. The strobe should not be shorted to ground; it should be current driven at  $-3\text{ mA}$  to  $-5\text{ mA}$  (see Figures 13 and 27).

## switching characteristics, $V_{CC\pm} = \pm 15\text{ V}, T_A = 25^\circ\text{C}$

PARAMETER	TEST CONDITIONS	LM111, LM211, LM311			UNIT
		MIN	TYP	MAX	
Response time, low-to-high-level output	$R_C = 500\ \Omega$ to $5\text{ V}, C_L = 5\text{ pF},$ See Note 7	115			ns
Response time, high-to-low-level output		165			ns

NOTE 7: The response time specified is for a 100-mV input step with 5-mV overdrive and is the interval between the input step function and the instant when the output crosses 1.4 V.



POST OFFICE BOX 655303 • DALLAS, TEXAS 75265

6-7

8961724 0094789 385

# LM111, LM211, LM311, LM311Y DIFFERENTIAL COMPARATORS WITH STROBES

SLCS007A - SEPTEMBER 1973 - REVISED FEBRUARY 1992

## electrical characteristics at $V_{CC\pm} = \pm 15$ V (unless otherwise noted)

PARAMETER	TEST CONDITIONS†	LM311Y			UNIT
		MIN	TYP	MAX	
$V_{IO}$ Input offset voltage	See Note 5		2	7.5	mV
$I_{IO}$ Input offset current	See Note 5		6	50	nA
$I_{IB}$ Input bias current	$V_O = 1$ V to 14 V		100	250	nA
$I_{IL(S)}$ Low-level strobe current (see Note 6)	$V_{(strobe)} = 0.3$ V, $V_{ID} \leq -10$ mV		-3		mA
$V_{ICR}$ Common-mode input voltage range		-14.5	13 to 13.8 to	-14.7	V
$A_{VD}$ Large-signal differential voltage amplification	$V_O = 5$ V to 35 V, $R_L = 1$ k $\Omega$	40	200		V/mV
$I_{OH}$ High-level (collector) output current	$I_{strobe} = -3$ mA, $V_{ID} = 5$ mV, $V_{OH} = 35$ V		0.2	50	nA
$V_{OL}$ Low-level (collector-to-emitter) output voltage	$I_{OL} = 50$ mA, $V_{ID} = -10$ mV		0.75	1.5	V
$I_{CC+}$ Supply current from $V_{CC+}$ , output low	$V_{ID} = -10$ mV, No load		5.1	7.5	mA
$I_{CC-}$ Supply current from $V_{CC-}$ , output low	$V_{ID} = 10$ mV, No load		-4.1	-5	mA

† Unless otherwise noted, all characteristics are measured with BALANCE and BAL/STRB open and the emitter output grounded.

NOTES: 5. The offset voltages and offset currents given are the maximum values required to drive the collector output up to 14 V or down to 1 V with a pullup resistor of 7.5 k $\Omega$  to  $V_{CC+}$ . These parameters actually define an error band and take into account the worst-case effects of voltage gain and input impedance.

6. The strobe should not be shorted to ground; it should be current driven at -3 mA to -5 mA (see Figures 13 and 27).

## switching characteristics, $V_{CC\pm} = \pm 15$ V, $T_A = 25^\circ\text{C}$

PARAMETER	TEST CONDITIONS	LM311Y			UNIT
		MIN	TYP	MAX	
Response time, low-to-high-level output	$R_C = 500$ $\Omega$ to 5 V, $C_L = 5$ pF, See Note 7		115		ns
Response time, high-to-low-level output			165		ns

NOTE 7: The response time specified is for a 100-mV input step with 5-mV overdrive and is the interval between the input step function and the instant when the output crosses 1.4 V.

8961724 0094790 0T7

 **TEXAS  
INSTRUMENTS**

POST OFFICE BOX 655303 • DALLAS, TEXAS 75265

TYPICAL CHARACTERISTICS†

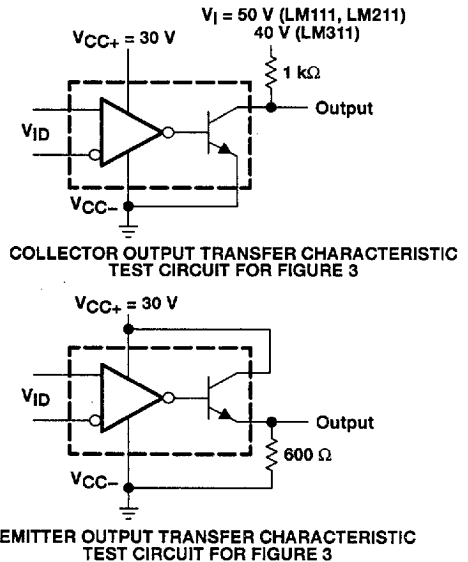
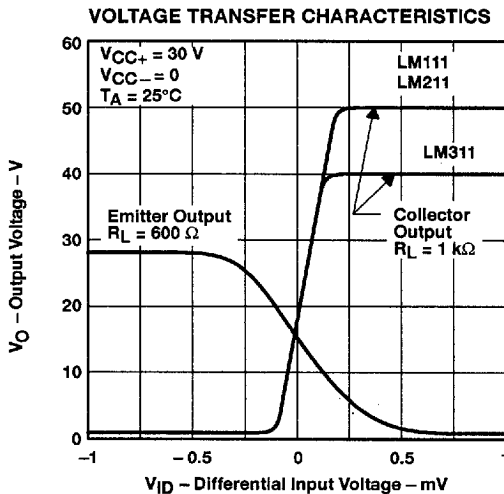
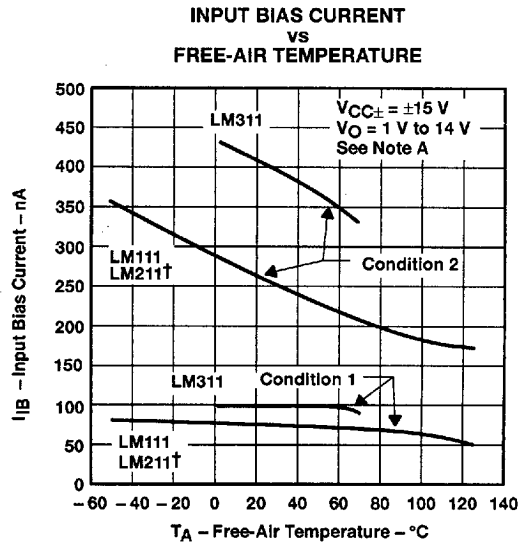
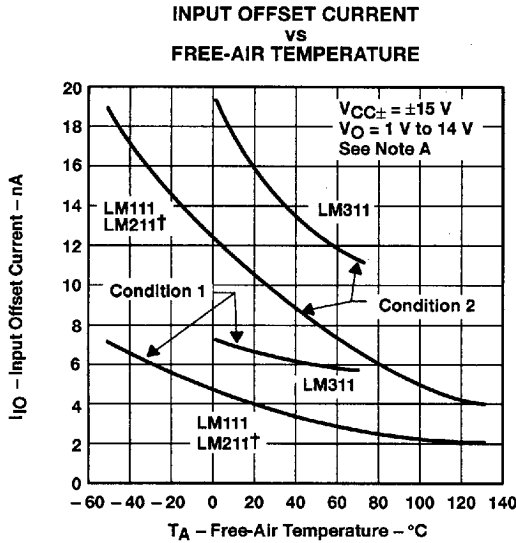

NOTE A: Condition 1 is with BALANCE and BAL/STRB open. Condition 2 is with BALANCE and BAL/STRB connected to  $V_{CC+}$ .  
† Data at high and low temperatures are applicable only within the rated operating free-air temperature ranges of the various devices.



# LM111, LM211, LM311, LM311Y DIFFERENTIAL COMPARATORS WITH STROBES

SLCS007A - SEPTEMBER 1973 - REVISED FEBRUARY 1992

## TYPICAL CHARACTERISTICS

OUTPUT RESPONSE FOR  
VARIOUS INPUT OVERDRIVES

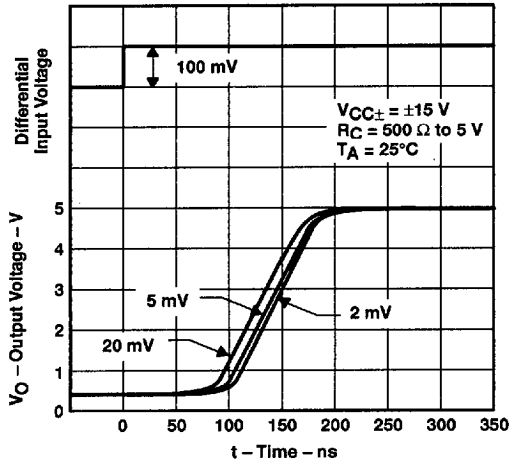

Figure 4

OUTPUT RESPONSE FOR  
VARIOUS INPUT OVERDRIVES

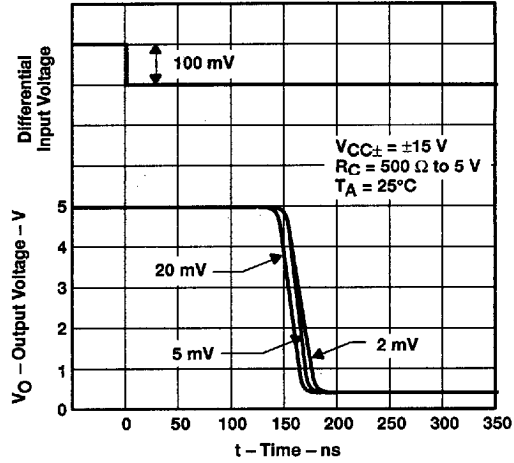
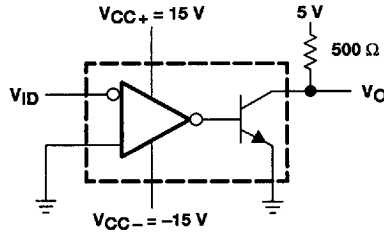

Figure 5



TEST CIRCUIT FOR FIGURES 4 AND 5

8961724 0094792 97T

**TEXAS  
INSTRUMENTS**

POST OFFICE BOX 655303 • DALLAS, TEXAS 75265



TYPICAL CHARACTERISTICS

OUTPUT RESPONSE FOR  
VARIOUS INPUT OVERDRIVES

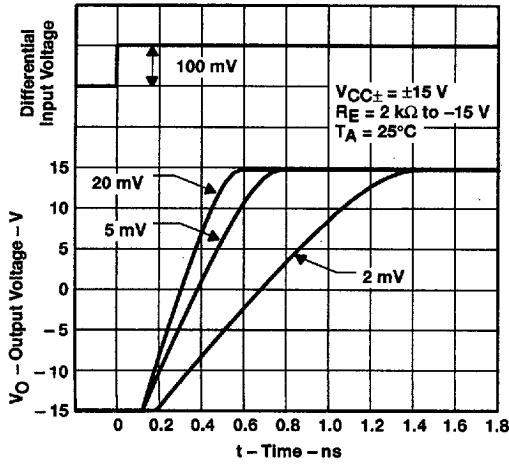

Figure 6

OUTPUT RESPONSE FOR  
VARIOUS INPUT OVERDRIVES

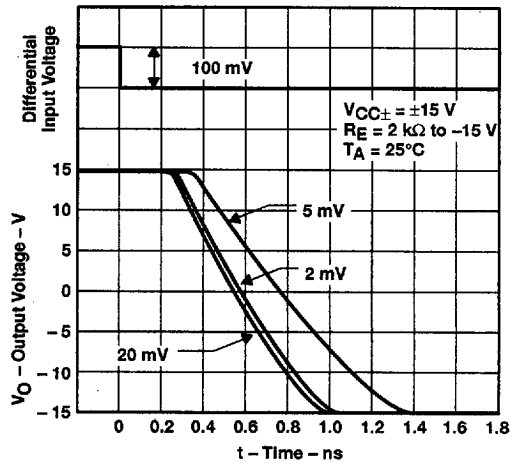
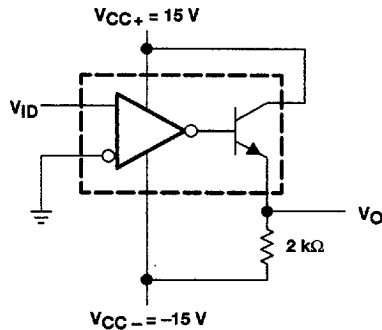

Figure 7



TEST CIRCUIT FOR FIGURES 6 AND 7



# LM111, LM211, LM311, LM311Y DIFFERENTIAL COMPARATORS WITH STROBES

SLCS007A - SEPTEMBER 1973 - REVISED FEBRUARY 1992

## TYPICAL CHARACTERISTICS

**OUTPUT CURRENT AND DISSIPATION  
vs  
OUTPUT VOLTAGE**

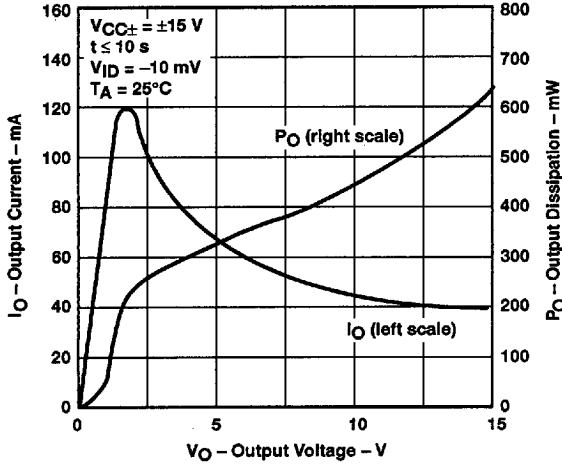

Figure 8

**POSITIVE SUPPLY CURRENT  
vs  
POSITIVE SUPPLY VOLTAGE**

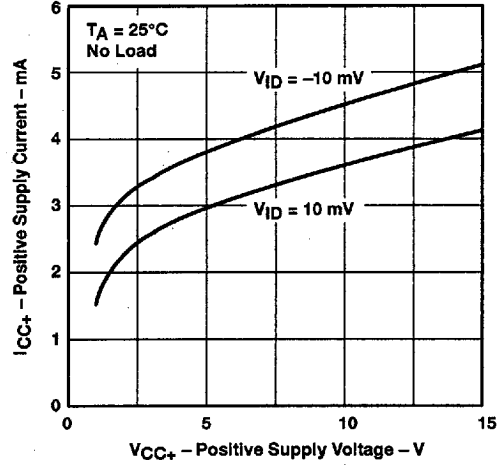

Figure 9

**NEGATIVE SUPPLY CURRENT  
vs  
NEGATIVE SUPPLY VOLTAGE**

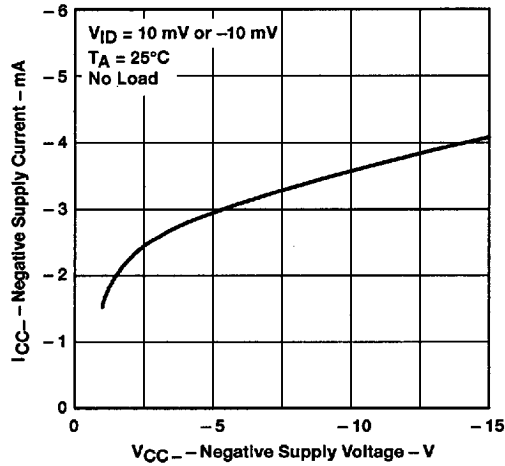

Figure 10

8961724 0094794 742

**TEXAS  
INSTRUMENTS**

POST OFFICE BOX 655303 • DALLAS, TEXAS 75265

APPLICATION INFORMATION

Figure 11 through Figure 29 show various applications for the LM111, LM211, and LM311 comparators.

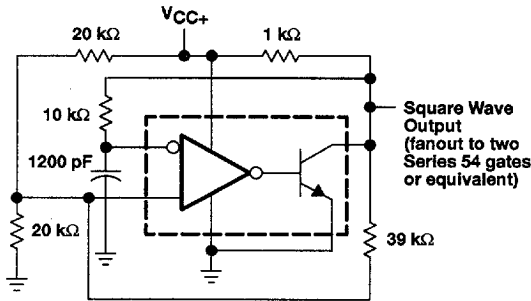

Figure 11. 100-kHz Free-Running Multivibrator

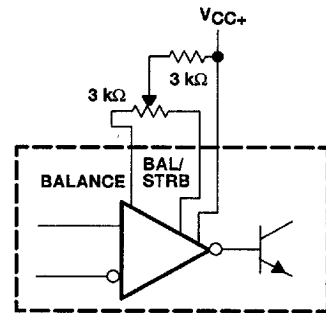

Figure 12. Offset Balancing

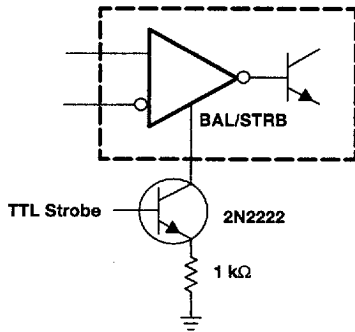

Figure 13. Strobing

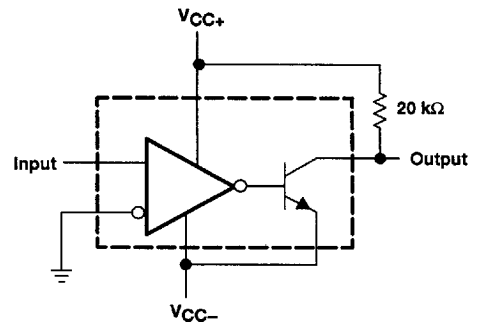
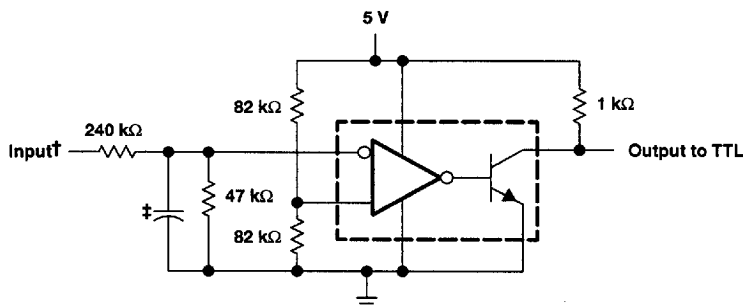

Figure 14. Zero-Crossing Detector



† Resistor values shown are for a 0-to-30-V logic swing and a 15-V threshold.  
‡ May be added to control speed and reduce susceptibility to noise spikes.

Figure 15. TTL interface With High-Level Logic

# LM111, LM211, LM311, LM311Y DIFFERENTIAL COMPARATORS WITH STROBES

SLCS007A - SEPTEMBER 1973 - REVISED FEBRUARY 1992

## APPLICATION INFORMATION

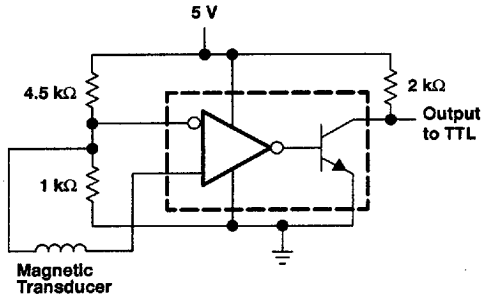

Figure 16. Detector for Magnetic Transducer

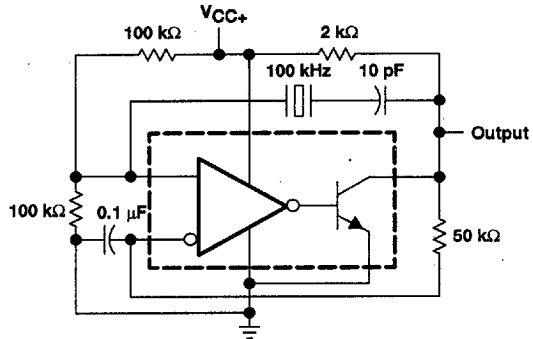

Figure 17. 100-kHz Crystal Oscillator

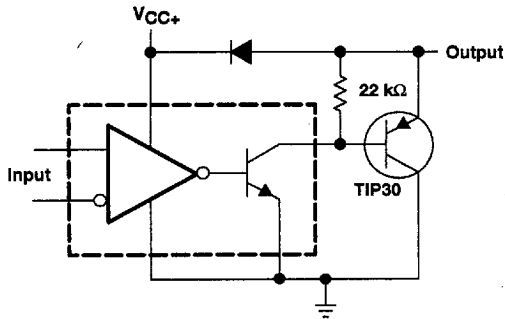
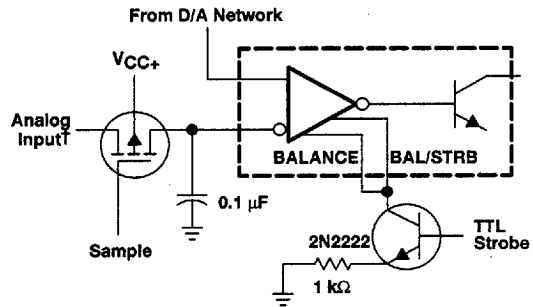

Figure 18. Comparator and Solenoid Driver



†Typical input current is 50 pA with inputs strobed off.

Figure 19. Strobing Both Input and Output Stages Simultaneously

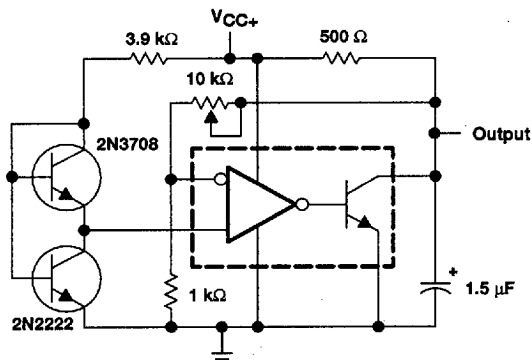

Figure 20. Low-Voltage Adjustable Reference Supply

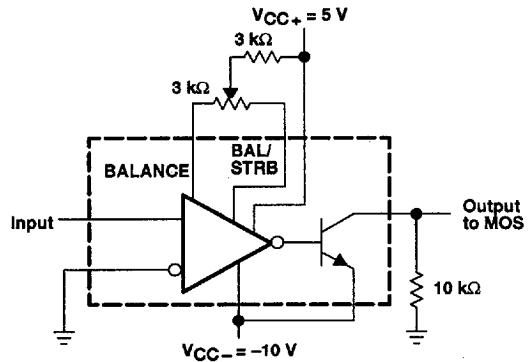

Figure 21. Zero-Crossing Detector Driving MOS Logic

8961724 0094796 515

**TEXAS  
INSTRUMENTS**

POST OFFICE BOX 655303 • DALLAS, TEXAS 75265

APPLICATION INFORMATION

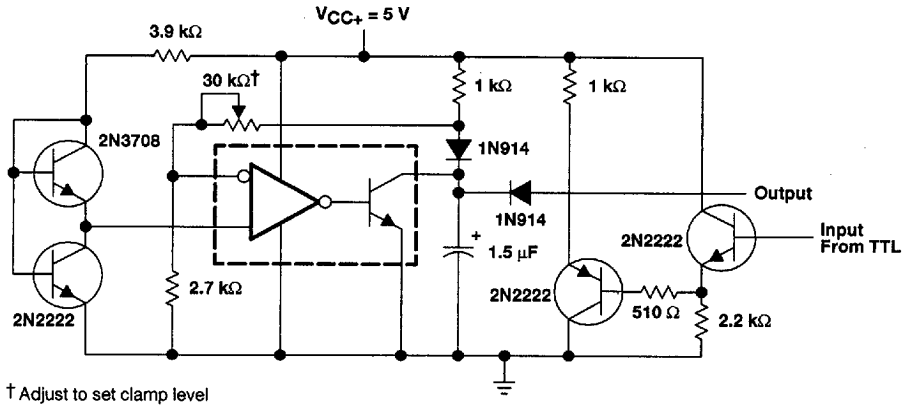

Figure 22. Precision Squarer

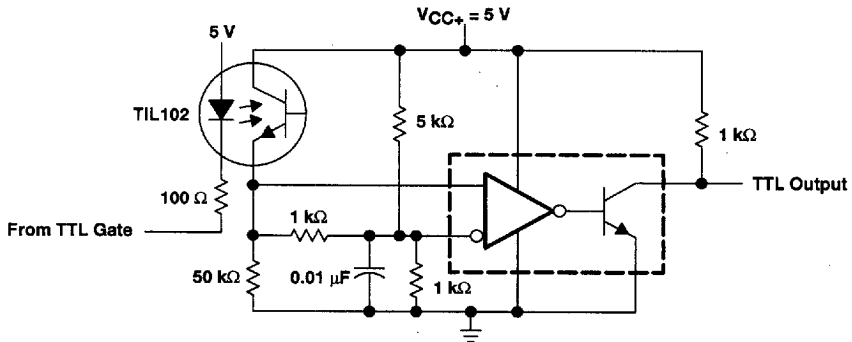

Figure 23. Digital Transmission Isolator

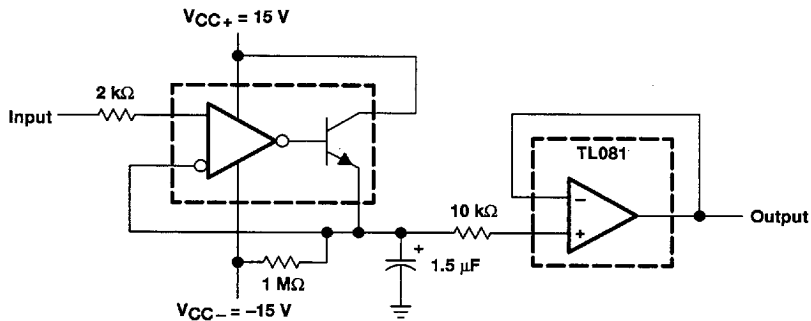

Figure 24. Positive-Peak Detector



POST OFFICE BOX 655303 • DALLAS, TEXAS 75265

8961724 0094797 451

# LM111, LM211, LM311, LM311Y DIFFERENTIAL COMPARATORS WITH STROBES

SLCS007A - SEPTEMBER 1973 - REVISED FEBRUARY 1992

## APPLICATION INFORMATION

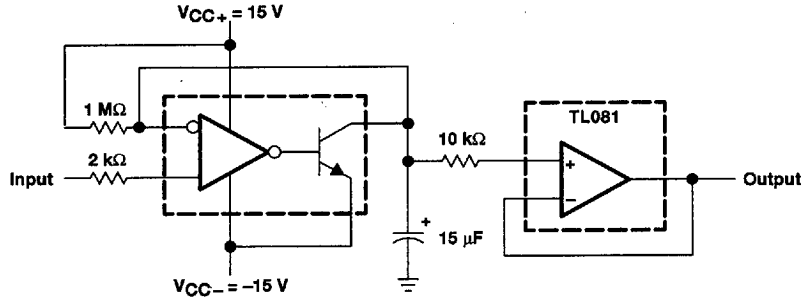
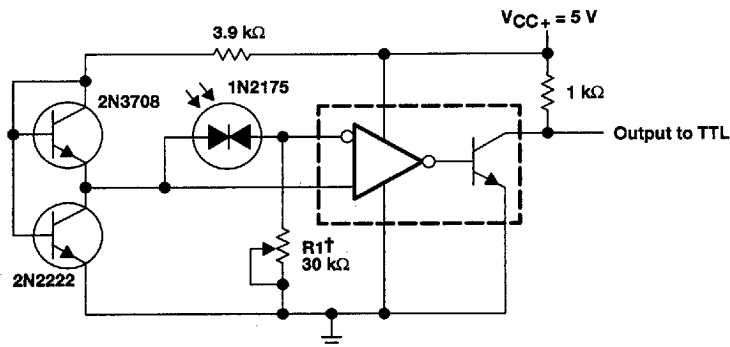
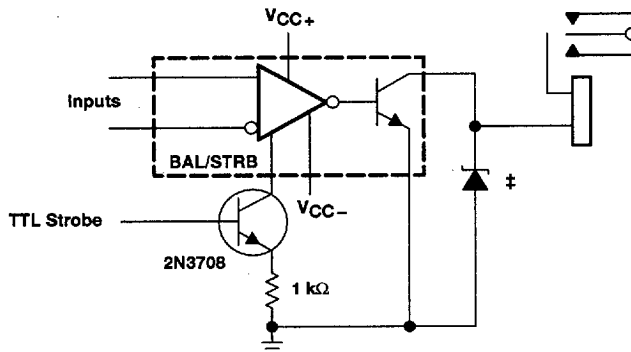

Figure 25. Negative-Peak Detector



† R1 sets the comparison level. At comparison, the photodiode has less than 5 mV across it decreasing dark current by an order of magnitude.

Figure 26. Precision Photodiode Comparator



‡ Transient voltage and inductive kickback protection

Figure 27. Relay Driver With Strobe

8961724 0094798 398

**TEXAS  
INSTRUMENTS**

POST OFFICE BOX 655303 • DALLAS, TEXAS 75265

# LM111, LM211, LM311, LM311Y DIFFERENTIAL COMPARATORS WITH STROBES

SLCS007A - SEPTEMBER 1973 - REVISED FEBRUARY 1992

## APPLICATION INFORMATION

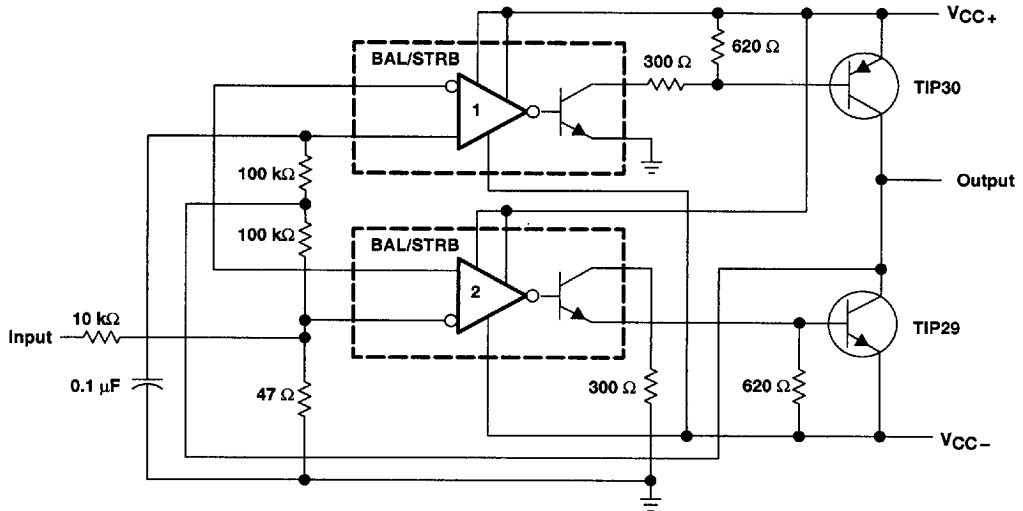

Figure 28. Switching Power Amplifier

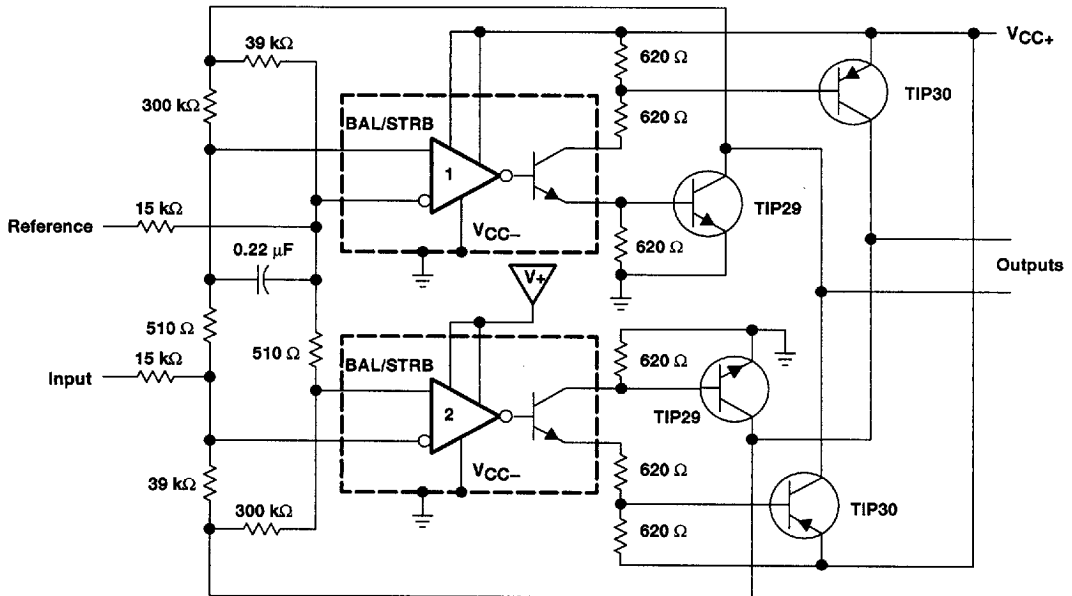

Figure 29. Switching Power Amplifiers

 **TEXAS  
INSTRUMENTS**

POST OFFICE BOX 655303 • DALLAS, TEXAS 75265

6-17

■ 8961724 0094799 224 ■