

MB1502/MB1502H

SERIAL INPUT PLL FREQUENCY SYNTHESIZER

LOW POWER SERIAL INPUT PLL SYNTHESIZER WITH 1.1 GHz PRESCALER

The Fujitsu MB1502/MB1502H, utilizing Bi-CMOS technology, are single chip serial input PLL synthesizers with pulse-swallow function. Each MB1502/MB1502H contains a 1.1GHz two modulus prescaler that can select of either 64/65 or 128/129 divide ratio, control signal generator, 16-bit shift register, 15-bit latch, programmable reference divider (binary 14-bit programmable reference counter), 1-bit switch counter, phase comparator with phase conversion function, charge pump, crystal oscillator, 19-bit shift register, 18-bit latch, programmable divider (binary 7-bit swallow counter and binary 11-bit programmable counter) and analog switch to speed up lock up time.

They operate at a supply voltage of 5V typ. and achieves a very low supply current of 8mA typ. realized through the use of Fujitsu Advanced Process Technology.

FEATURES

- High operating frequency: $f_{IN\ MAX}=1.1\text{GHz}$ ($V_{IN\ MIN}=10\text{dBm}$)
- Pulse swallow function: 64/65 or 128/129
- Low supply current: $I_{CC}=8\text{mA}$ typ.
- Serial input 18-bit programmable divider consisting of:
 - Binary 7-bit swallow counter: 0 to 127
 - Binary 11-bit programmable counter: 16 to 2047
- Serial input 15-bit programmable reference divider consisting of:
 - Binary 14-bit programmable reference counter: 8 to 16383
 - 1-bit switch counter (SW) sets divide ratio of prescaler
- On-chip analog switch achieves fast lock up time
- 2 types of phase detector output
 - On-chip charge pump (Bipolar type)
 - Output for external charge pump
- Wide operating temperature: -40°C to $+85^{\circ}\text{C}$
- 16-pin Plastic DIP Package (Suffix: —P)
16-pin Plastic Flat Package (Suffix: —PF)

ABSOLUTE MAXIMUM RATINGS (See NOTE)

Rating	Symbol	Value	Unit
Power Supply Voltage	V_{CC}	-0.5 to +7.0	V
	V_P	V_{CC} to 10.0	V
Output Voltage	V_{OUT}	-0.5 to $V_{CC} + 0.5$	V
Open-drain Voltage	V_{OOP}	-0.5 to 0.8	V
Output Current	I_{OUT}	± 10	mA
Storage Temperature	T_{STG}	-55 to +125	$^{\circ}\text{C}$

NOTE: Permanent device damage may occur if the above Absolute Maximum Ratings are exceeded. Functional operation should be restricted to the conditions as detailed in the operational sections of this data sheet. Exposure to absolute maximum rating conditions for extended periods may affect device reliability.

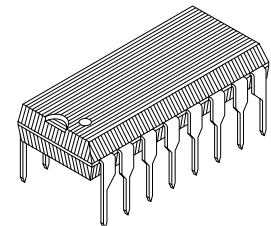

Plastic Package
DIP-16P-M04

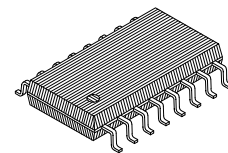

Plastic Package
FPT-16P-M06

Pin Assignment

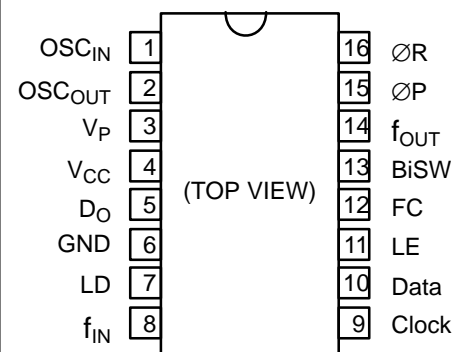

This device contains circuitry to protect the inputs against damage due to high static voltages or electric fields. However, it is advised that normal precautions be taken to avoid application of any voltage higher than maximum rated voltages to this high impedance circuit.

MB1502
MB1502H

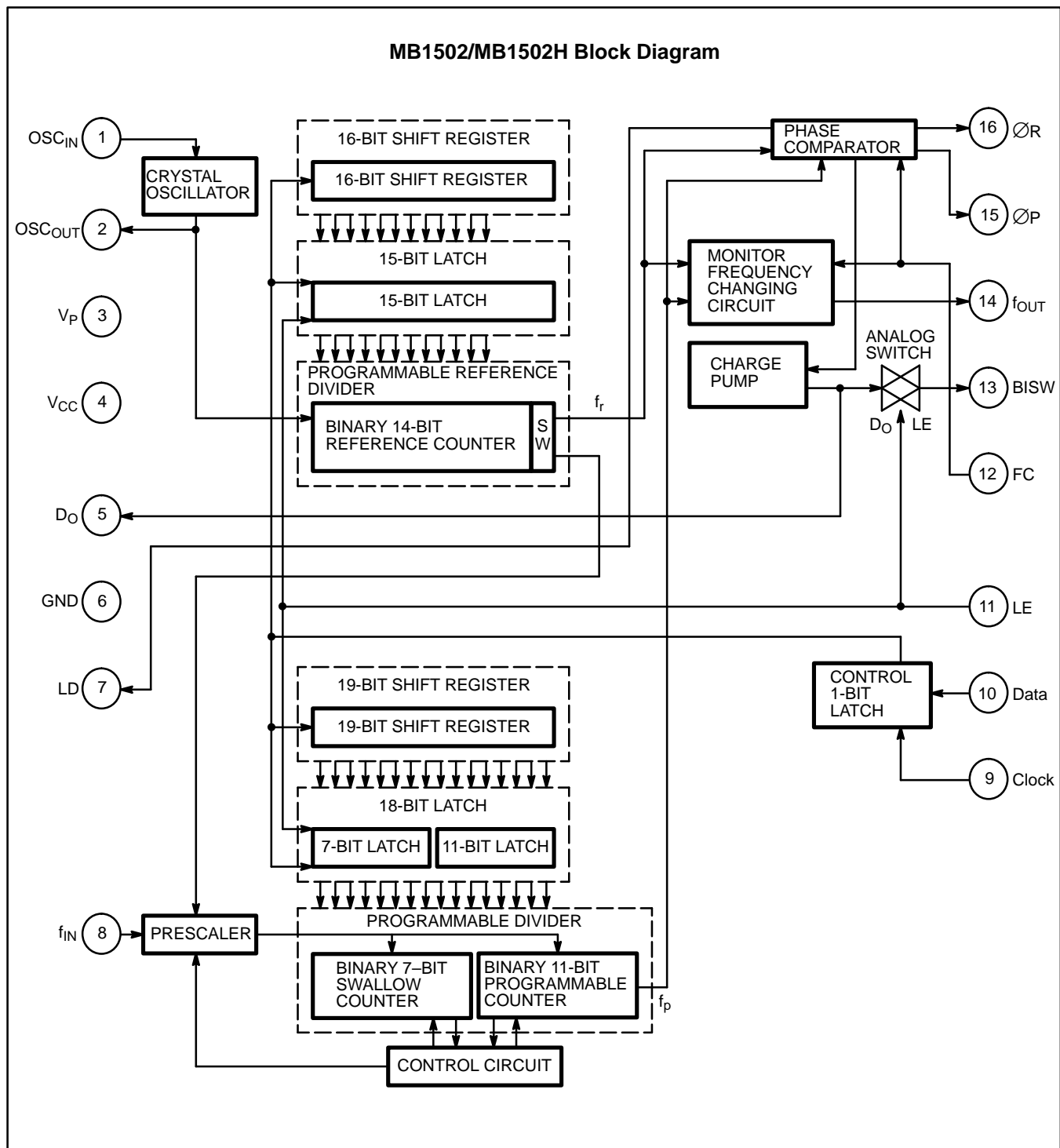

PIN DESCRIPTION

Pin No.	Pin Name	I/O	Description
1 2	OSC _{IN} OSC _{OUT}	I O	Oscillator input. Oscillator output. A crystal is placed between OSC _{IN} and OSC _{OUT} .
3	V _P	—	Power supply input for charge pump and analog switch.
4	V _{CC}	—	Power supply voltage input.
5	D _O	O	Charge pump output. The characteristics of charge pump is reversed depending upon FC input.
6	GND	—	Ground
7	LD	O	Phase comparator output. Normally this pin outputs high level. While the phase difference of f _r and f _p exists, this pin outputs low level.
8	f _{IN}	I	Prescaler input. The connection with an external VCO should be AC connection.
9	Clock	I	Clock input for 19-bit shift register and 16-bit shift register. On rising edge of the clock shifts one bit of data into the shift registers.
10	Data	I	Binary serial data input. The last bit of the data is a control bit which specified destination of shift registers. When this bit is high level and LE is high level, the data stored in shift register is transferred to 15-bit latch. When this bit is low level and LE is high level, the data is transferred to 18-bit latch.
11	LE	I	Load enable input (with internal pull up resistor). When LE is high or open, the data stored in shift register is transferred into latch depending upon the control bit. At the time, internal charge pump output to be connected to BISW pin because internal analog switch becomes ON state.
12	FC	I	Phase select input of phase comparator (with internal pull up resistor). When FC is low level, the characteristics of charge pump, phase comparator is reversed. FC input signal is also used to control f _{OUT} pin (test pin) output level for f _r or f _p .
13	BISW	O	Analog switch output. Usually BISW pin is set high-impedance state. When internal analog switch is ON (LE pin is high level), this pin outputs internal charge pump state.
14	f _{OUT}	O	Monitor pin of phase comparator input. f _{OUT} pin outputs either programmable reference divider output (f _r) or programmable divider output (f _p) depending upon FC pin input level.
15 16	ØP ØR	O O	Outputs for external charge pump. The characteristics are reversed according to FC input. ØP pin is N-channel open drain output.

FUNCTIONAL DESCRIPTIONS

SERIAL DATA INPUT

Serial data input is achieved by three inputs, such as Data pin, Clock pin and LE pin. Serial data input controls 15-bit programmable reference divider and 18-bit programmable divider, respectively.

Binary serial data is input to Data pin.

On rising edge of clock shifts one bit of serial data into the internal shift registers and when load enable pin is high level or open, stored data is transferred into latch depending upon the control bit.

Control data “H” data is transferred into 15-bit latch.

Control data “L” data is transferred into 18-bit latch.

PROGRAMMABLE REFERENCE DIVIDER

Programmable reference divider consists of 16-bit shift register, 15-bit latch and 14-bit reference counter. Serial 16-bit data format is shown below.

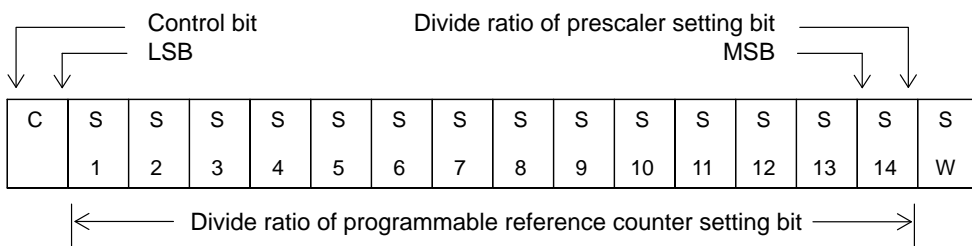

14-BIT PROGRAMMABLE REFERENCE COUNTER DIVIDE RATIO

Divide Ratio R	S14	S13	S12	S11	S10	S9	S8	S7	S6	S5	S4	S3	S2	S1
8	0	0	0	0	0	0	0	0	0	0	1	0	0	0
9	0	0	0	0	0	0	0	0	0	0	1	0	0	1
•	•	•	•	•	•	•	•	•	•	•	•	•	•	•
16383	1	1	1	1	1	1	1	1	1	1	1	1	1	1

NOTES: Divide ratio less than 8 is prohibited.
Divide ratio: 8 to 16383
SW: This bit selects divide ratio of prescaler.
SW=H : 64
SW=L :128
S1 to S14: These bits select divide ratio of programmable reference divider.
C: Control bit (sets as high level).
Data is input from MSB side.

PROGRAMMABLE DIVIDER

Programmable divider consists of 19-bit shift register, 18-bit latch, 7-bit swallow counter and 11-bit programmable counter.

Serial 19-bit data format is shown on following page.

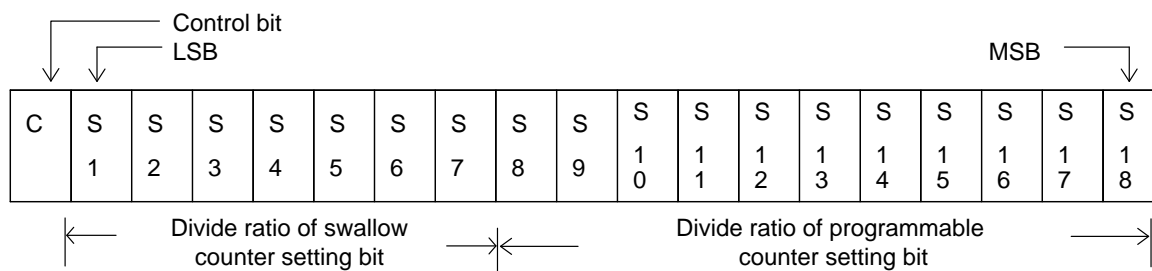

7-BIT SWALLOW COUNTER DIVIDE RATIO

Divide Ratio A	S	S	S	S	S	S	S
	7	6	5	4	3	2	1
0	0	0	0	0	0	0	0
1	0	0	0	0	0	0	1
•	•	•	•	•	•	•	•
127	1	1	1	1	1	1	1

NOTE: Divide ratio: 0 to 127

11-BIT PROGRAMMABLE COUNTER DIVIDE RATIO

Divide Ratio N	S	S	S	S	S	S	S	S	S	S	S
	1	1	1	1	1	1	1	1	1	9	8
	8	7	6	5	4	3	2	1	0		
16	0	0	0	0	0	0	1	0	0	0	1
17	0	0	0	0	0	0	1	0	0	0	1
•	•	•	•	•	•	•	•	•	•	•	•
2047	1	1	1	1	1	1	1	1	1	1	1

NOTES: Divide ratio less than 16 is prohibited.
Divide ratio: 16 to 2047
S1 to S7: Swallow counter divide ratio setting bit. (0 to 127)
S8 to S18: Programmable counter divide ratio setting bit. (16 to 2047)
C: Control bit (sets as low level).
Data is input from MSB side.

PULSE SWALLOW FUNCTION

$$f_{VCO} = [(PxN)+A] \times f_{OSC} \div R$$

f_{VCO} : Output frequency of external voltage controlled oscillator (VCO)

N: Preset divide ratio of binary 11-bit programmable counter (16 to 2047)

A: Preset divide ratio of binary 7-bit swallow counter ($0 \leq A \leq 127$, $A < N$)

f_{OSC} : Output frequency of the external reference frequency oscillator

R: Preset divide ratio of binary 14-bit programmable reference counter (8 to 16383)

P: Preset modulus of external dual modulus prescaler (64 or 128)

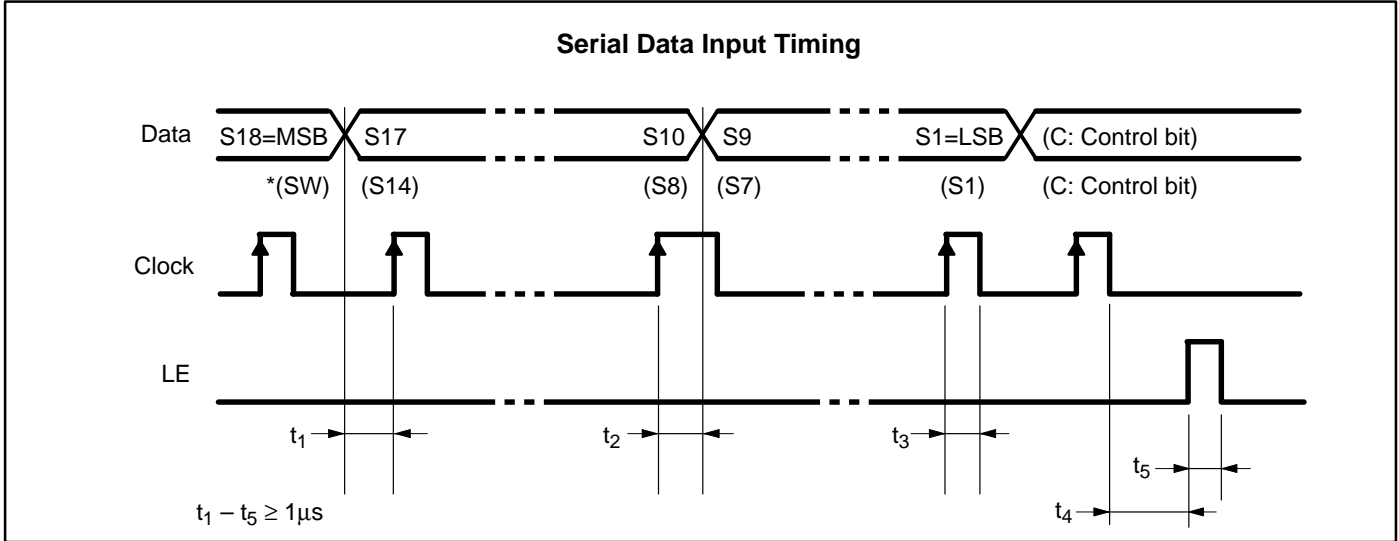

NOTES: Parenthesis data is used for setting divide ratio of programmable reference divider.
On rising edge of clock shifts one bit of data in the shift register.

PHASE CHARACTERISTICS

FC pin is provided to change phase characteristics of phase comparator. Characteristics of internal charge pump output level (D_o), phase comparator output level ($\phi R, \phi P$) are reversed depending upon FC pin input level. Also, monitor pin (f_{OUT}) output level of phase comparator is controlled by FC pin input level. The relation between outputs ($D_o, \phi R, \phi P$) and FC input level are shown below.

	FC=H or open				FC=L			
	D_o	ϕR	ϕP	f_{OUT}	D_o	ϕR	ϕP	f_{OUT}
$f_r > f_p$	H	L	L	(f_r)	L	H	Z	(f_p)
$f_r < f_p$	L	H	Z	(f_r)	H	L	L	(f_p)
$f_r = f_p$	Z	L	Z	(f_r)	Z	L	Z	(f_p)

Note: Z = (High impedance)

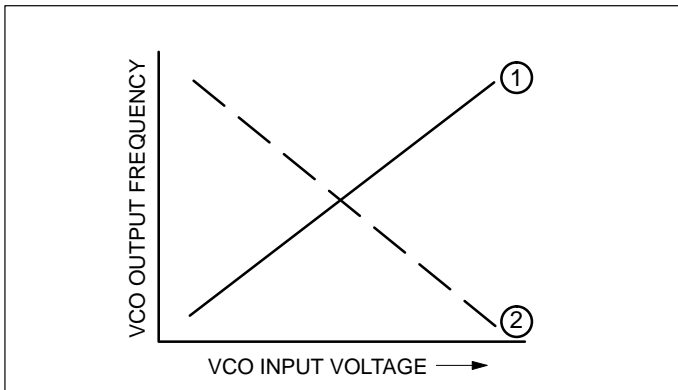

VCO CHARACTERISTICS

Depending upon VCO characteristics, FC pin should be set accordingly:

- When VCO characteristics are like **1**, FC should be set High or open circuit;
- When VCO characteristics are like **2**, FC should be set Low.

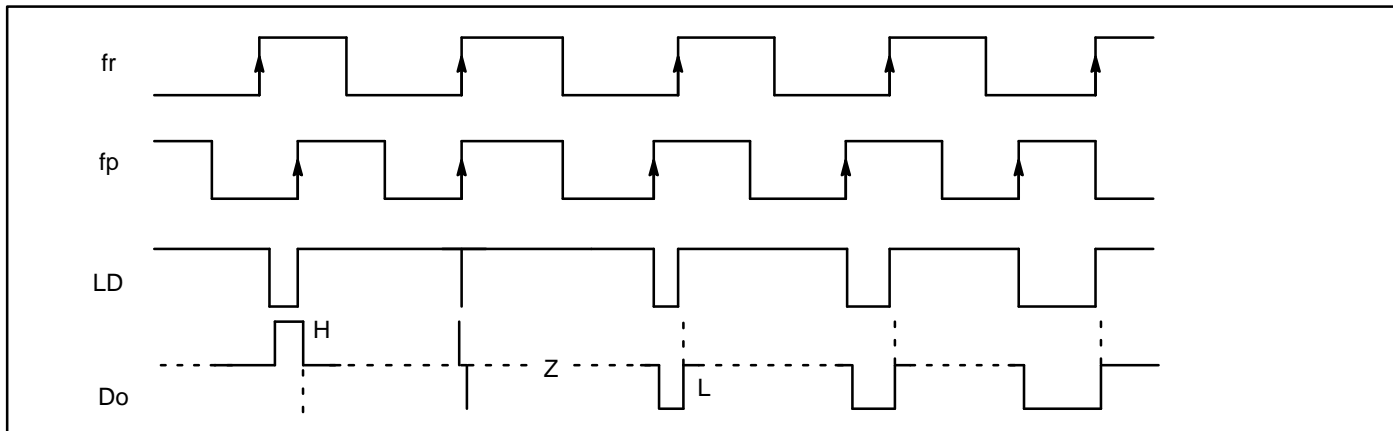

NOTES: Phase difference detection range: -2π to $+2\pi$
 Spike appearance depends on charge pump characteristics. Also, the spike is output in order to diminish dead band.
 When $f_r > f_p$ or $f_r < f_p$, spike might not appear depending upon charge pump characteristics.

ANALOG SWITCH

ON/OFF of analog switch is controlled by LE input signal. When the analog switch is ON, internal charge pump output (D_O) to be connected to BISW pin. When the analog switch is OFF, BISW pin is set to high-impedance state.

LE=H (Changing the divide ratio of internal prescaler) : Analog switch=ON
 LE=L (Normal operating mode): Analog switch=OFF

LPF time constant is decreased in order to insert a analog switch between LPF1 and LPF2 when channel of PLL is changing. Thus, lock up time is decreased, that is, fast lock up time is achieved.

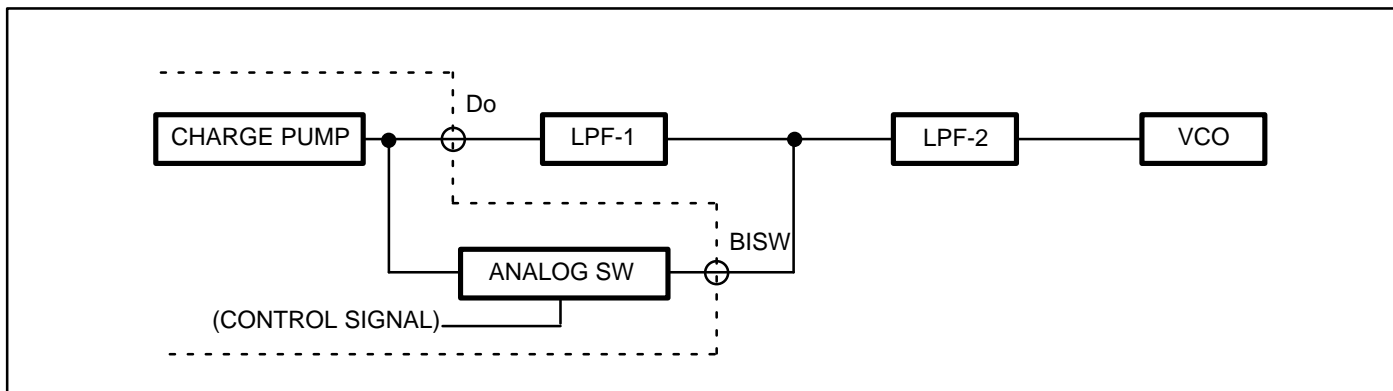

RECOMMENDED OPERATING CONDITIONS

Parameter	Symbol	Value			Unit
		Min	Typ	Max	
Power Supply Voltage	V_{CC}	4.5	5.0	5.5	V
	V_P	V_{CC}	V_P	8.0	V
Input Voltage	V_I	GND		V_{CC}	V
Operating Temperature	T_A	-40		85	$^{\circ}\text{C}$

ELECTRICAL CHARACTERISTICS

(V_{CC}=4.5 to 5.5V, T_A=-40 to +85°C, unless otherwise noted.)

Parameter	Symbol	Condition	Value			Unit		
			Min	Typ	Max			
Power Supply Current	I _{CC}	Note 1		8.0	12.0	mA		
Operating Frequency	f _{in}	f _{in}	Note2	10		1100	MHz	
	OSC _{IN}	f _{OSC}			12	20	MHz	
Input Sensitivity	f _{in}	V _{fin}		-10		6	dBm	
	OSC _{IN}	V _{OSC}		0.5			V _{PP}	
High-level Input Voltage	Except f _{in} and OSC _{IN}	V _{IH}		V _{CC} ×0.7			V	
Low-level Input Voltage		V _{IL}				V _{CC} ×0.3		V
High-level Input Current	Data Clock	I _{IH}			1.0		μA	
Low-level Input Current		I _{IL}			-1.0		μA	
Input Current	OSC _{IN}	I _{OSC}			±50		μA	
	LE, FC	I _{LE}			-60		μA	
High-level Output Voltage	Except D _O and OSC _{OUT}	V _{OH}	V _{CC} = 5 V	4.4			V	
Low-level Output Voltage		V _{OL}				0.4	V	
N-channel Open Drain Cutoff Current	D _O , ØP	I _{OFF}	V _P = V _{CC} to 8V V _{OOP} = GND to 8V			1.1	μA	
Output Current	Except D _O and OSC _{OUT}	I _{OH}		-1.0			mA	
		I _{OL}		1.0			mA	
High-level Output Current	D _O D _O	I _{DDH}	MB1502	V _{CC} =5V, V _P = 8V, T _A =25°C	-0.8	-1.5		mA
Low-level Output Current		I _{DOL}			11	22		mA
High-level Output Current		I _{DOLH}	MB1502H		-1.4	-2.4		mA
Low-level Output Current		I _{DOLH}			4.5	10		mA
Analog Switch On Resistor		R _{ON}			25		Ω	

NOTE: 1: f_{in} = 1.1GHz, OSC_{IN}=12MHz, V_{CC}=5V. Inputs are grounded and outputs are open.
2: AC coupling. Minimum operating frequency is measured when a capacitor 1000pF is connected.

TYPICAL CHARACTERISTICS CURVES

INPUT SENSITIVITY CHARACTERISTICS

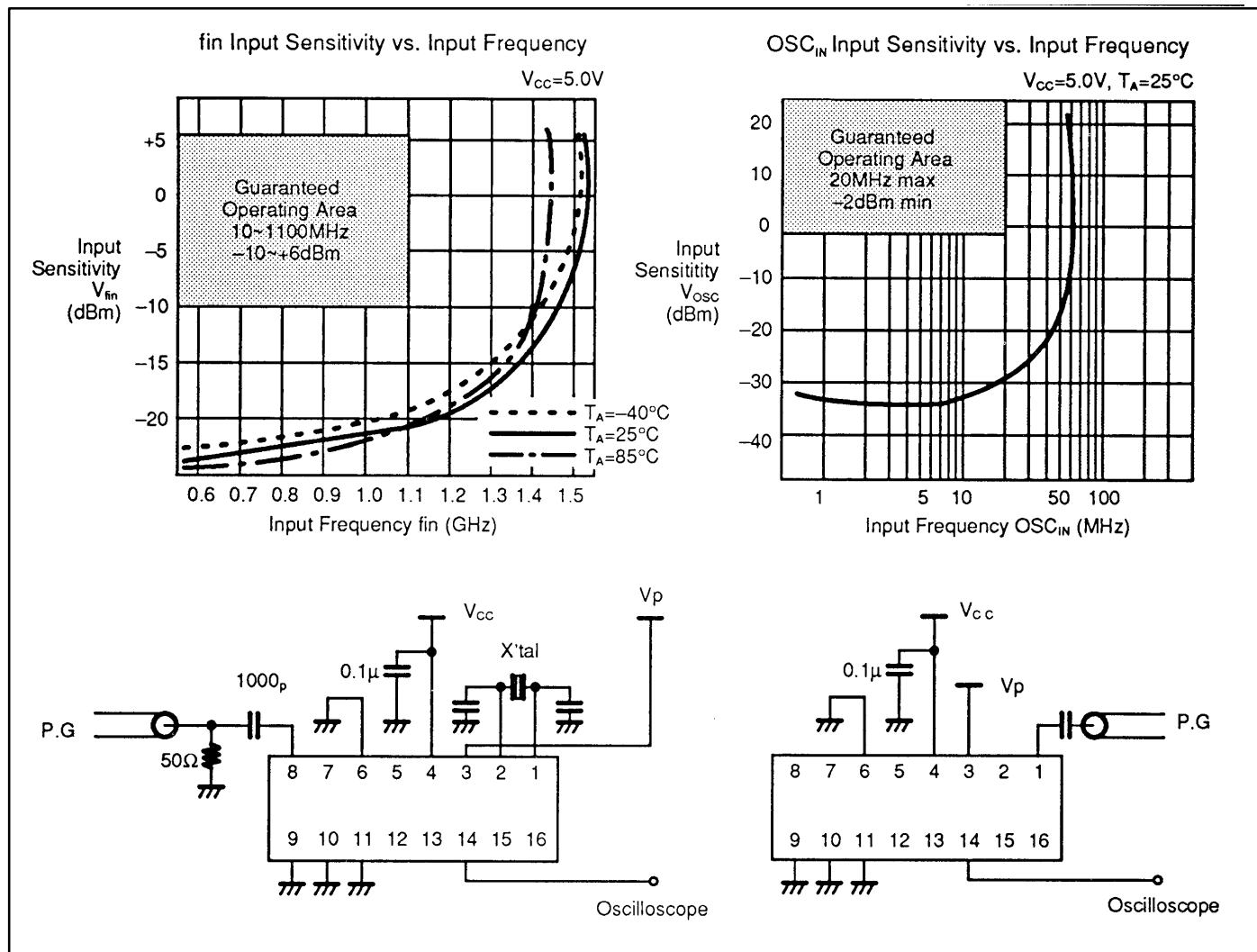

DO PIN OUTPUT CURRENT CURVES (TYPICAL)

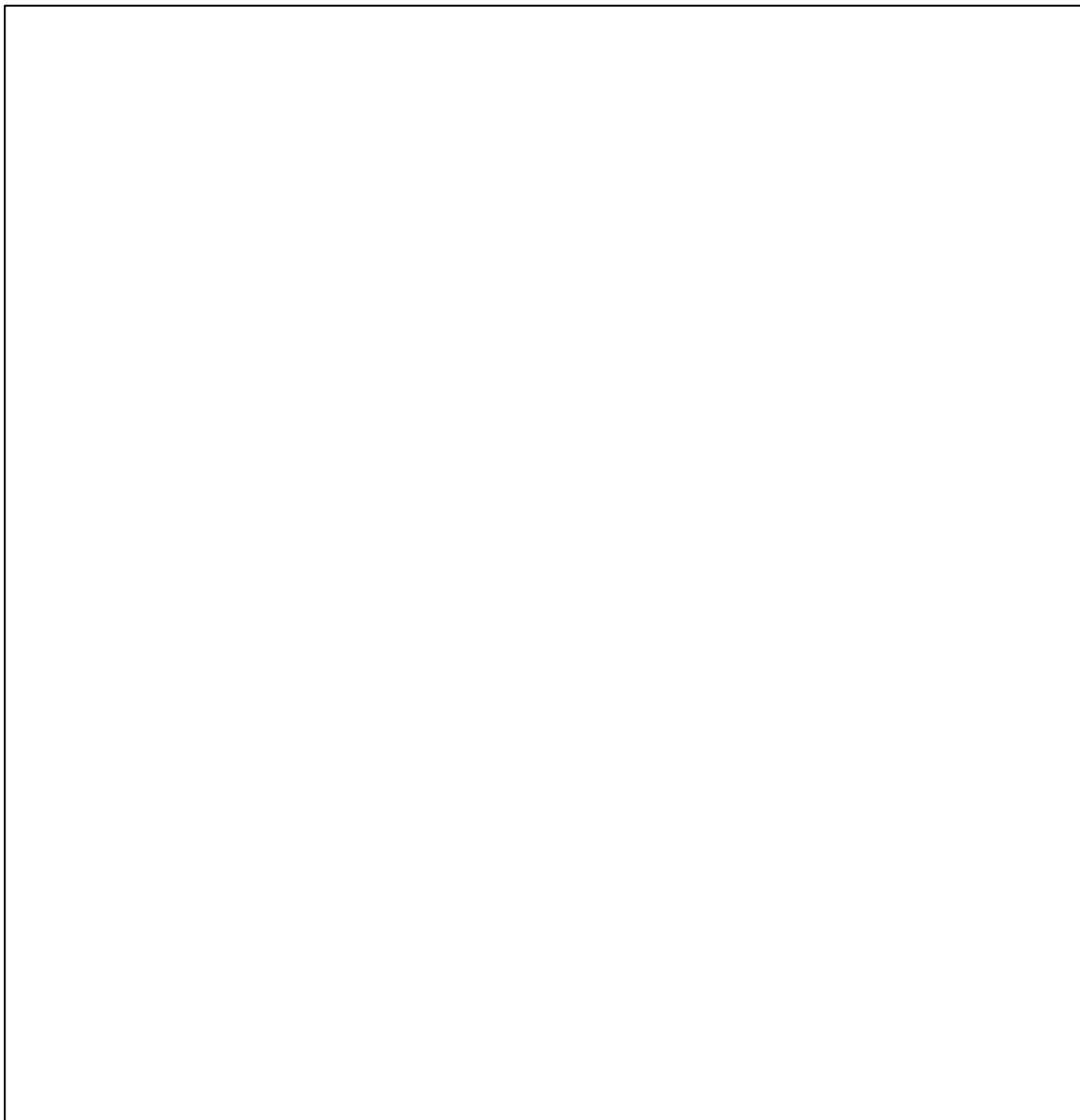

INPUT IMPEDANCE CHARACTERISTICS

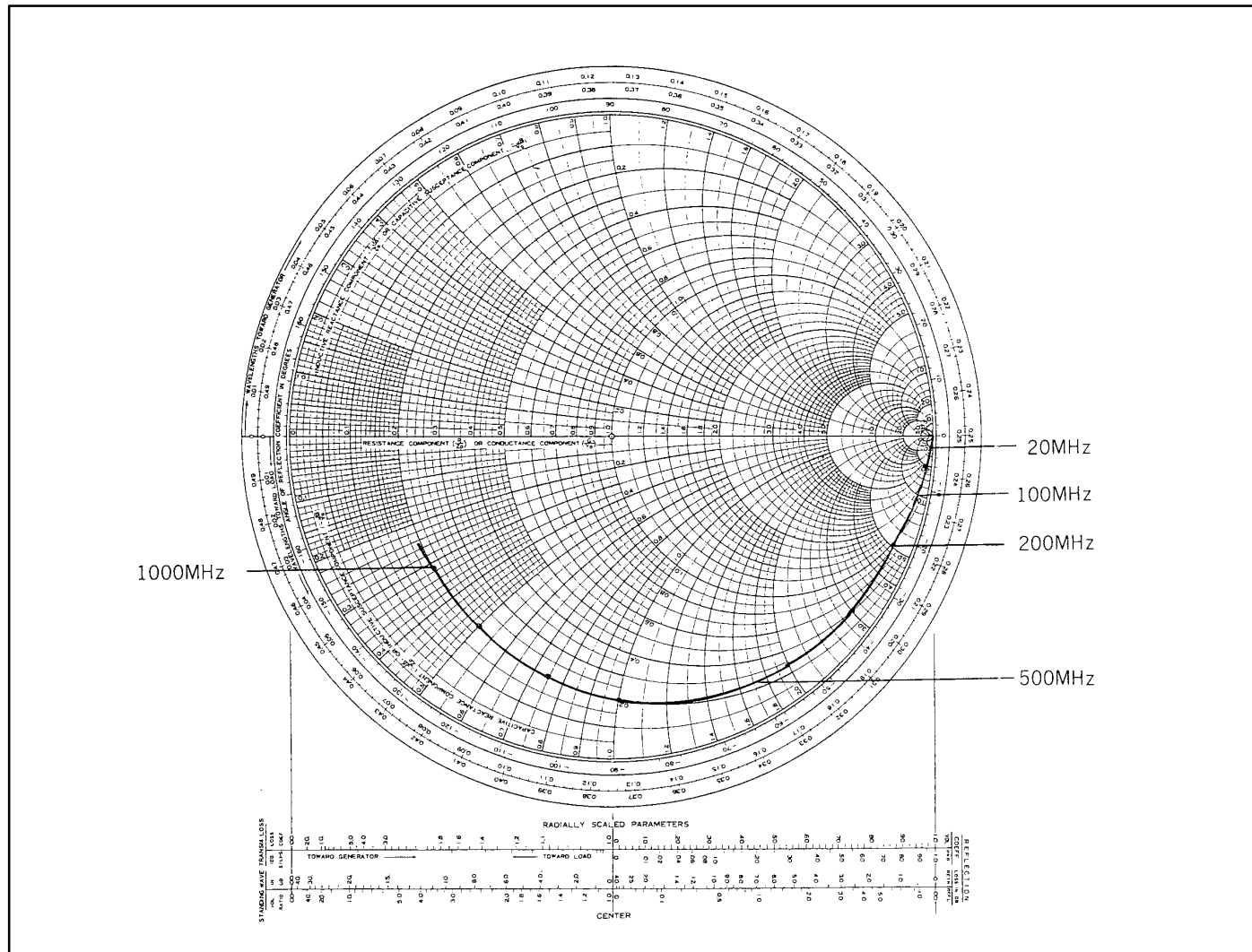

TYPICAL APPLICATION EXAMPLE

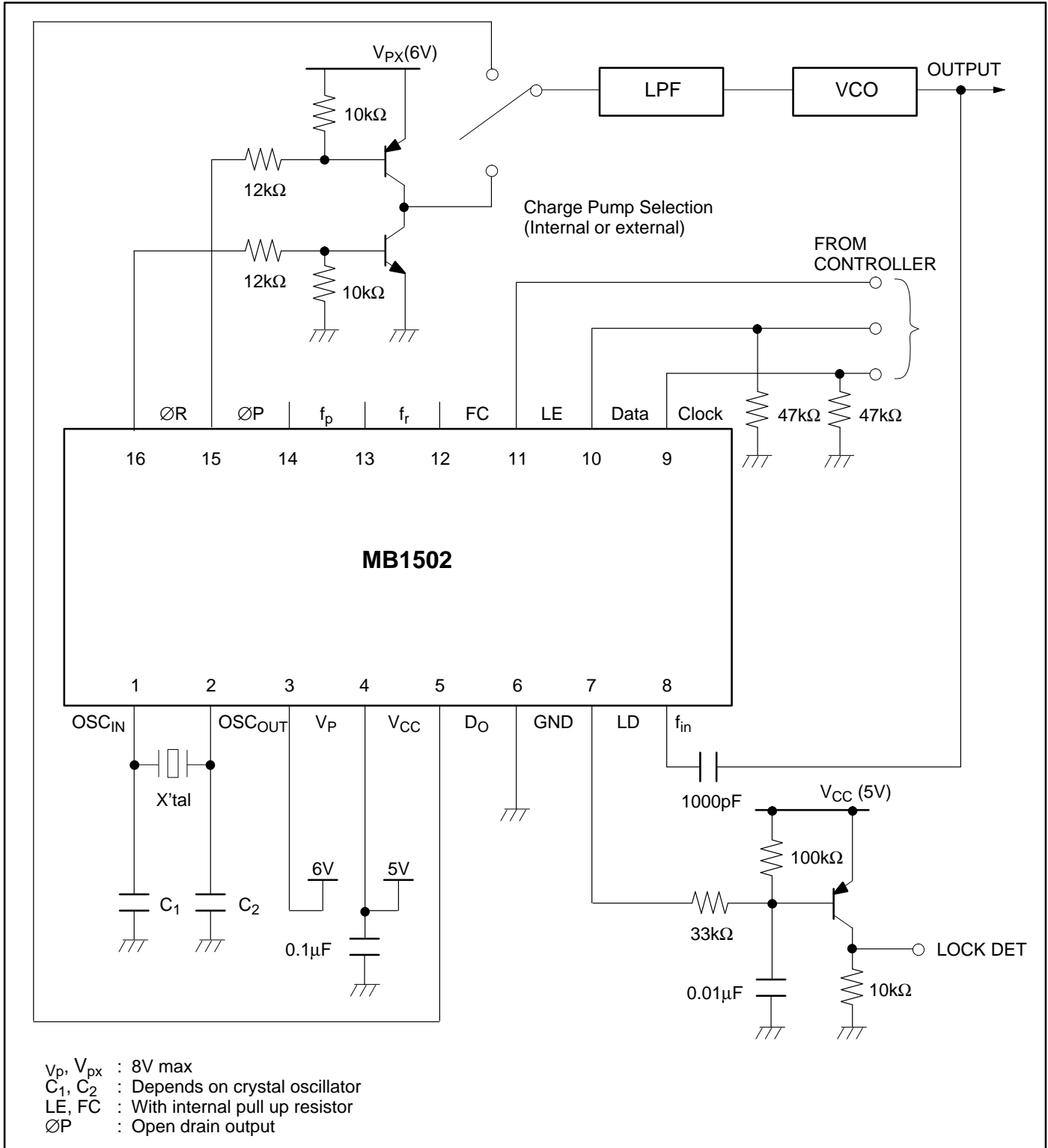

PACKAGE DIMENSIONS

16-Lead Plastic Dual In-Line Package
(Case No.: DIP-16P-M04)

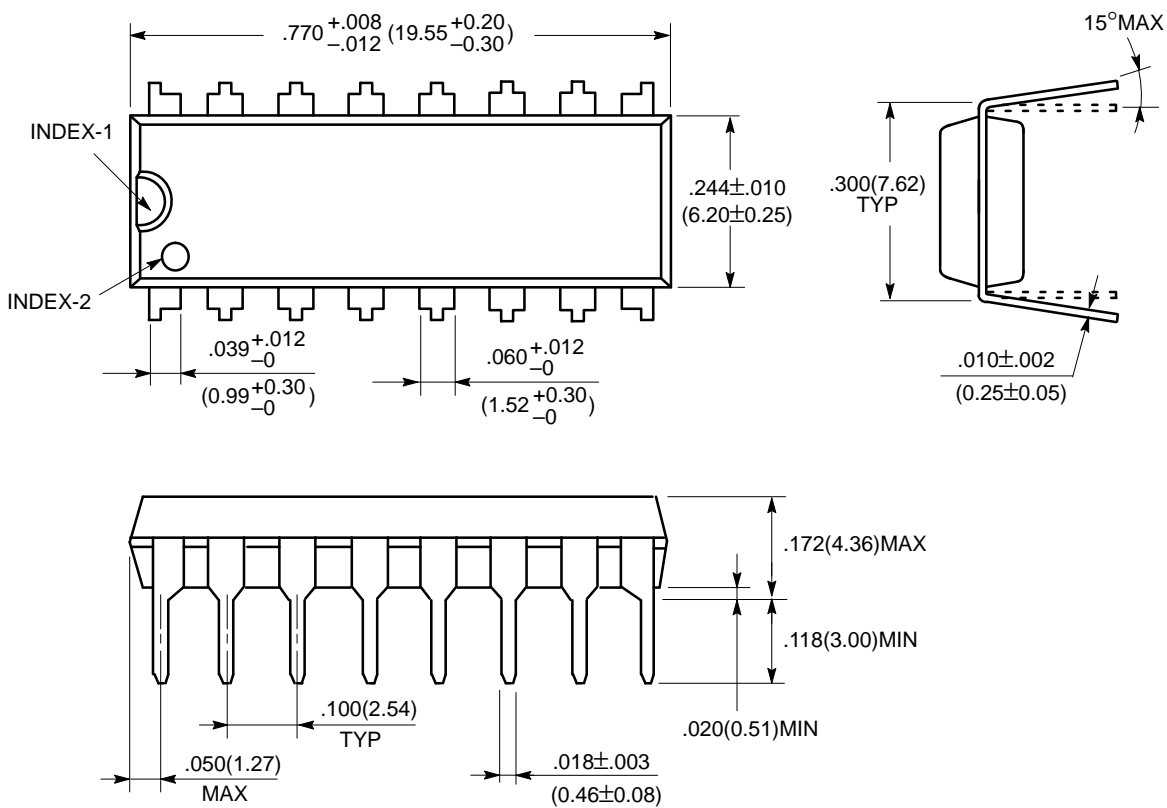

©1991 FUJITSU LIMITED D16033S-2C

Dimensions in
inches (millimeters)

16-Lead Plastic Flat Package
(Case No.: FPT-16P-M06)

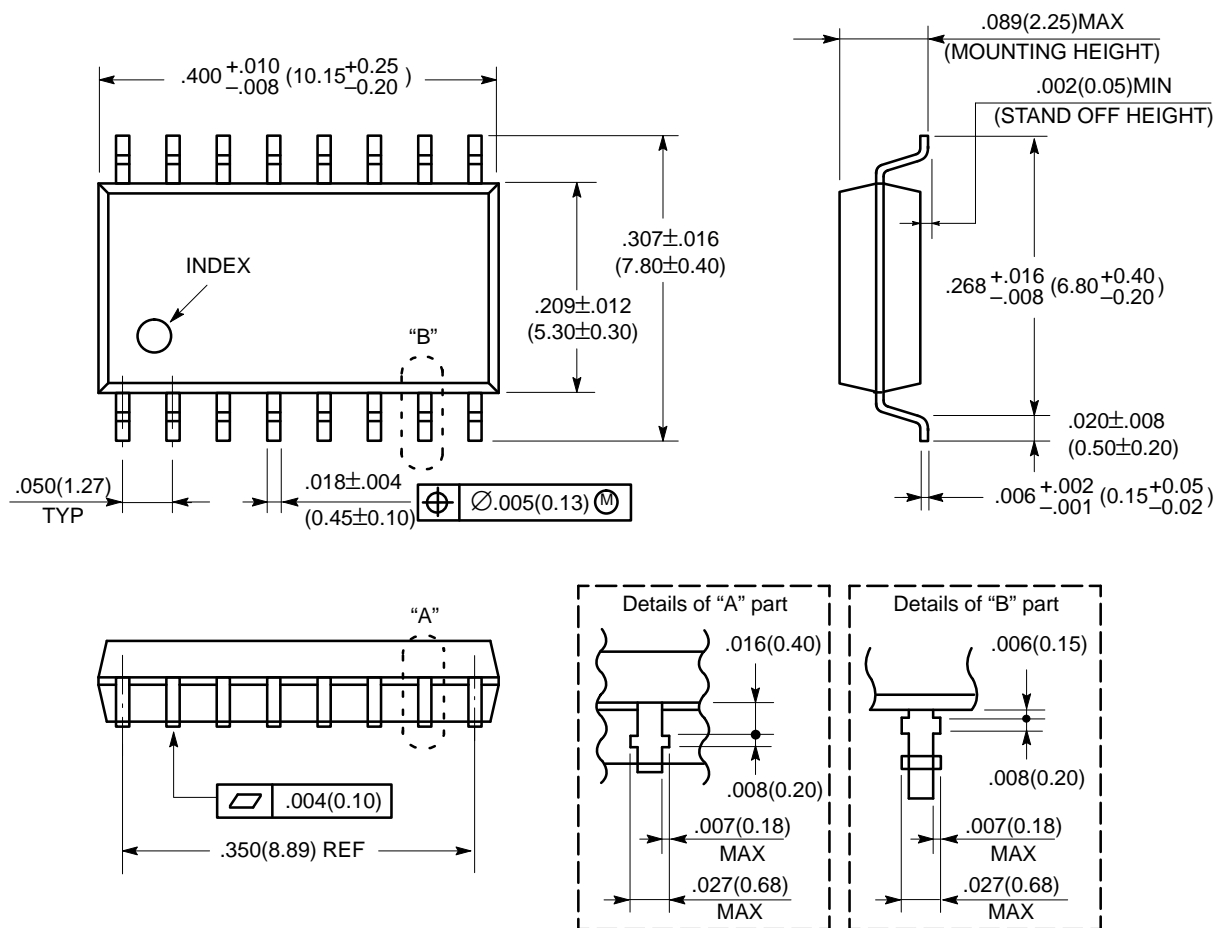

©1991 FUJITSU LIMITED F16015S-2C

Dimensions in
inches (millimeters)

All Rights Reserved.

Circuit diagrams utilizing Fujitsu products are included as a means of illustrating typical semiconductor applications. Complete Information sufficient for construction purposes is not necessarily given.

The information contained in this document has been carefully checked and is believed to be reliable. However, Fujitsu assumes no responsibility for inaccuracies.

The information contained in this document does not convey any license under the copyrights, patent rights or trademarks claimed and owned by Fujitsu.

Fujitsu reserves the right to change products or specifications without notice.

No part of this publication may be copied or reproduced in any form or by any means, or transferred to any third party without prior written consent of Fujitsu.

FUJITSU LIMITED

For further information, please contact:

Japan

FUJITSU LIMITED
Semiconductor Marketing
Furukawa Sogo Bldg.
6-1,Marunouchi 2-chome
Chiyoda-ku, Tokyo 100
Japan
Tel: (03)3216-3211
Telex: 781-2224361
FAX: (03)3216-9771

North and South America

FUJITSU MICROELECTRONICS, INC.
Semiconductor Division
3545 North First Street
San Jose, CA 95134-1804 USA
Tel: (408)922-9000
FAX: (408)432-9044

Europe

FUJITSU MIKROELEKTRONIK GmbH
Arabella Centre 9.0G
Lyoner Strasse 44-48
D-6000 Frankfurt 71
F.R. Germany
Tel: (069) 66320
Telex: 411963
FAX: (069) 6632122

Asia

FUJITSU MICROELECTRONICS ASIA PTE LIMITED
51 Bras Basah Road
Plaza by the Park
#06-04/07
Singapore 0718
Tel: 336-1600
Telex: 55373
FAX: 336-1609