

- Low Supply Voltage Range 1.8 V to 3.6 V
 - Ultralow-Power Consumption
 - Active Mode: 270 μ A at 1 MHz, 2.2 V
 - Standby Mode: 0.7 μ A
 - Off Mode (RAM Retention): 0.1 μ A
 - Ultrafast Wake-Up From Standby Mode in Less Than 1 μ s
 - 16-Bit RISC Architecture, 62.5-ns Instruction Cycle Time
 - Basic Clock Module Configurations:
 - Internal Frequencies up to 16 MHz With Four Calibrated Frequencies to $\pm 1\%$
 - Internal Very-Low-Power Low-Frequency Oscillator
 - 32-kHz Crystal
 - High-Frequency Crystal up to 16 MHz
 - Resonator
 - External Digital Clock Source
 - External Resistor
 - 16-Bit Timer_A With Three Capture/Compare Registers
 - 16-Bit Timer_B With Three Capture/Compare Registers
 - Universal Serial Communication Interface
 - Enhanced UART Supporting Auto-Baudrate Detection (LIN)
 - IrDA Encoder and Decoder
 - Synchronous SPI
 - I²C™
 - 10-Bit, 200-ksps A/D Converter With Internal Reference, Sample-and-Hold, Autoscan, and Data Transfer Controller
 - Two Configurable Operational Amplifiers (MSP430x22x4 Only)
 - Brownout Detector
 - Serial Onboard Programming, No External Programming Voltage Needed
 - Programmable Code Protection by Security Fuse
 - Bootstrap Loader
 - On Chip Emulation Module
 - Family Members Include:
 - MSP430F2232: 8KB + 256B Flash Memory 512B RAM
 - MSP430F2252: 16KB + 256B Flash Memory 512B RAM
 - MSP430F2272: 32KB + 256B Flash Memory 1KB RAM
 - MSP430F2234: 8KB + 256B Flash Memory 512B RAM
 - MSP430F2254: 16KB + 256B Flash Memory 512B RAM
 - MSP430F2274: 32KB + 256B Flash Memory 1KB RAM
- Available in a 38-Pin Thin Shrink Small-Outline Package (TSSOP) and 40-Pin QFN Package
- For Complete Module Descriptions, Refer to the *MSP430x2xx Family User's Guide*

description

The Texas Instruments MSP430 family of ultralow-power microcontrollers consist of several devices featuring different sets of peripherals targeted for various applications. The architecture, combined with five low-power modes is optimized to achieve extended battery life in portable measurement applications. The device features a powerful 16-bit RISC CPU, 16-bit registers, and constant generators that contribute to maximum code efficiency. The digitally controlled oscillator (DCO) allows wake-up from low-power modes to active mode in less than 1 μ s.

The MSP430x22xx series is an ultralow-power mixed signal microcontroller with two built-in 16-bit timers, a universal serial communication interface, 10-bit A/D converter with integrated reference and data transfer controller (DTC), two general-purpose operational amplifiers in the MSP430x22x4 devices, and 32 I/O pins.

Typical applications include sensor systems that capture analog signals, convert them to digital values, and then process the data for display or for transmission to a host system. Stand-alone radio-frequency (RF) sensor front ends are another area of application.



Please be aware that an important notice concerning availability, standard warranty, and use in critical applications of Texas Instruments semiconductor products and disclaimers thereto appears at the end of this data sheet.

All trademarks are the property of their respective owners.

PRODUCTION DATA information is current as of publication date. Products conform to specifications per the terms of Texas Instruments standard warranty. Production processing does not necessarily include testing of all parameters.



POST OFFICE BOX 655303 • DALLAS, TEXAS 75265
POST OFFICE BOX 1443 • HOUSTON, TEXAS 77251-1443

Copyright © 2007 Texas Instruments Incorporated

MSP430x22x2, MSP430x22x4 MIXED SIGNAL MICROCONTROLLER

SLAS504B – JULY 2006 – REVISED JULY 2007

AVAILABLE OPTIONS

| T _A | PACKAGED DEVICES | |
|----------------|---|---|
| | PLASTIC 38-PIN TSSOP (DA) | PLASTIC 40-PIN QFN (RHA) |
| -40°C to 85°C | MSP430F2232IDA MSP430F2252IDA MSP430F2272IDA MSP430F2234IDA MSP430F2254IDA MSP430F2274IDA | MSP430F2232IRHA MSP430F2252IRHA MSP430F2272IRHA MSP430F2234IRHA MSP430F2254IRHA MSP430F2274IRHA |
| -40°C to 105°C | MSP430F2232TDA† MSP430F2252TDA† MSP430F2272TDA† MSP430F2234TDA MSP430F2254TDA MSP430F2274TDA | MSP430F2232TRHA† MSP430F2252TRHA† MSP430F2272TRHA† MSP430F2234TRHA MSP430F2254TRHA MSP430F2274TRHA |

† Product Preview



MSP430x22x2 device pinout, DA package

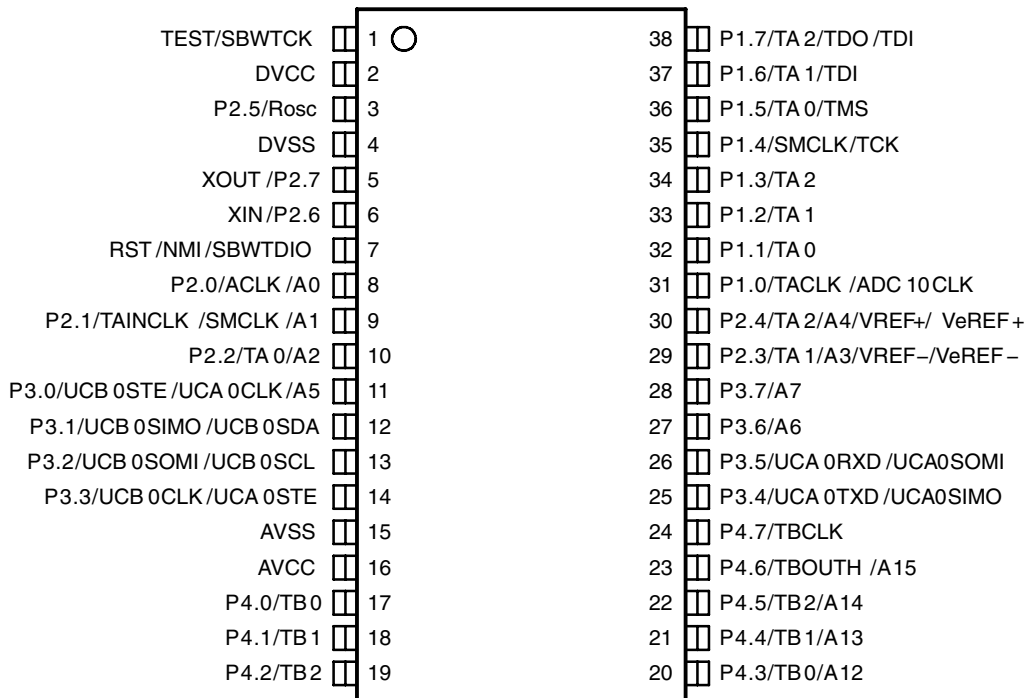

MSP430x22x4 device pinout, DA package

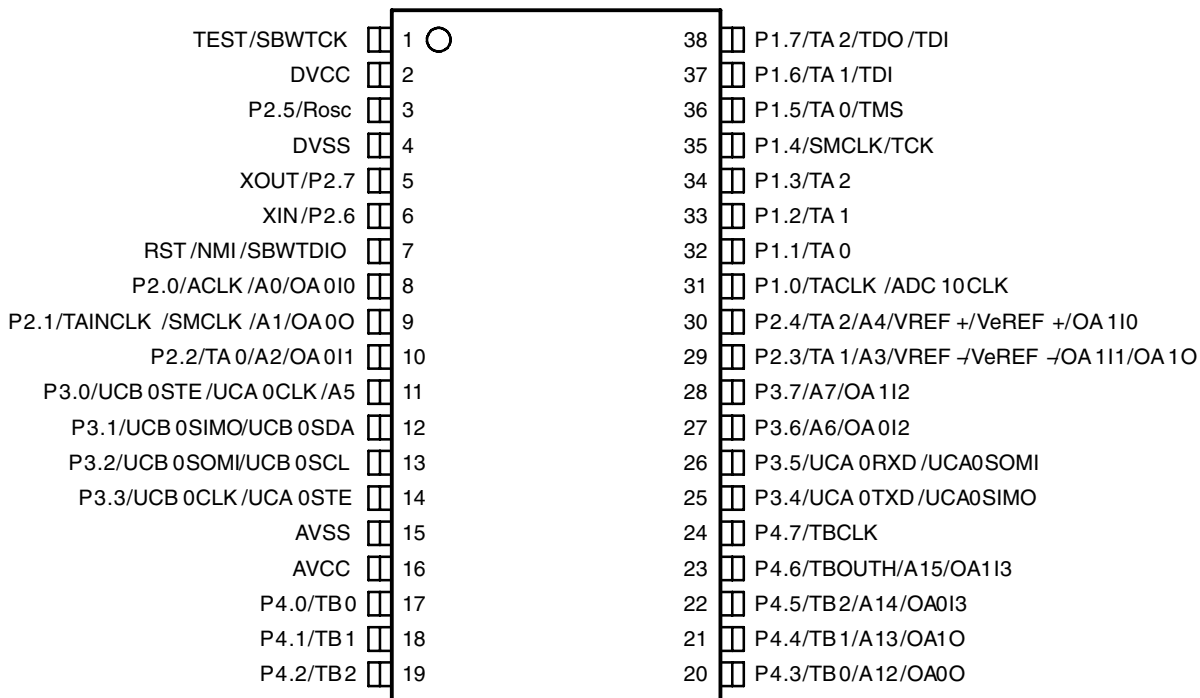

MSP430x22x2, MSP430x22x4 MIXED SIGNAL MICROCONTROLLER

SLAS504B – JULY 2006 – REVISED JULY 2007

MSP430x22x2 device pinout, RHA package

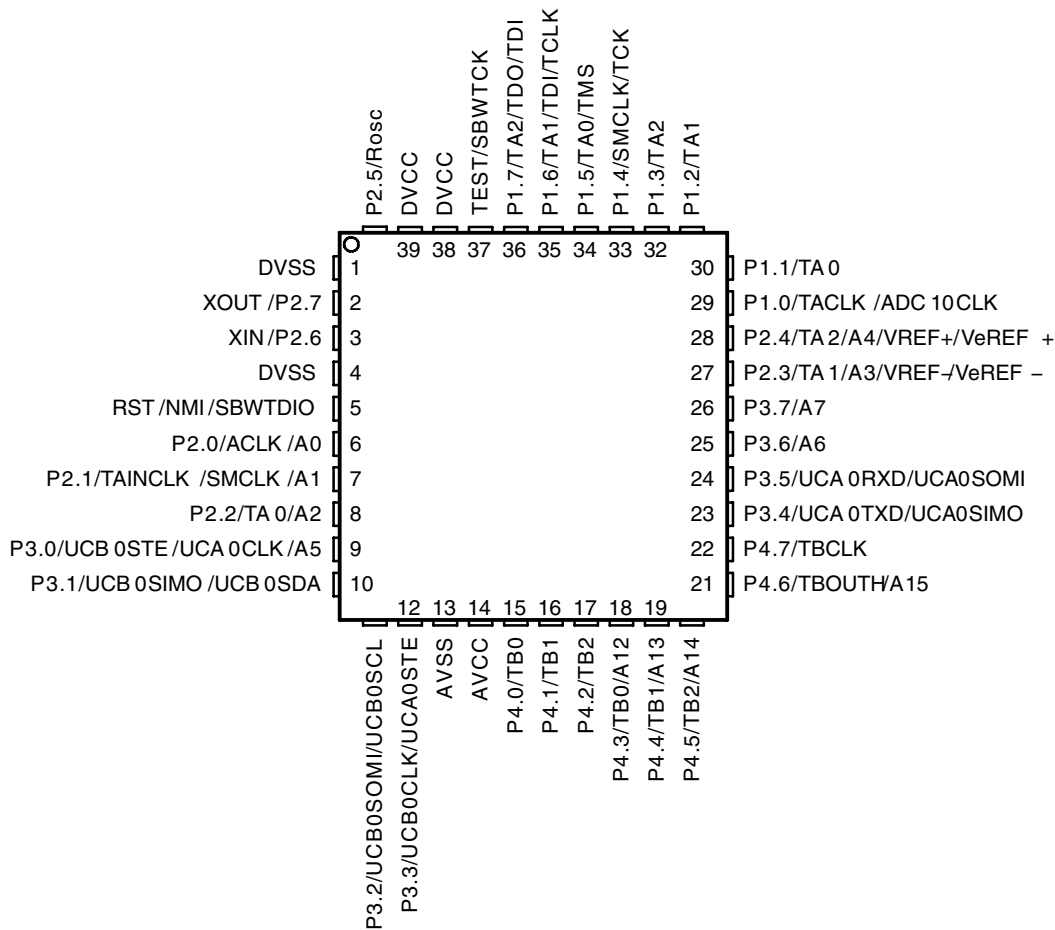

MSP430x22x4 device pinout, RHA package

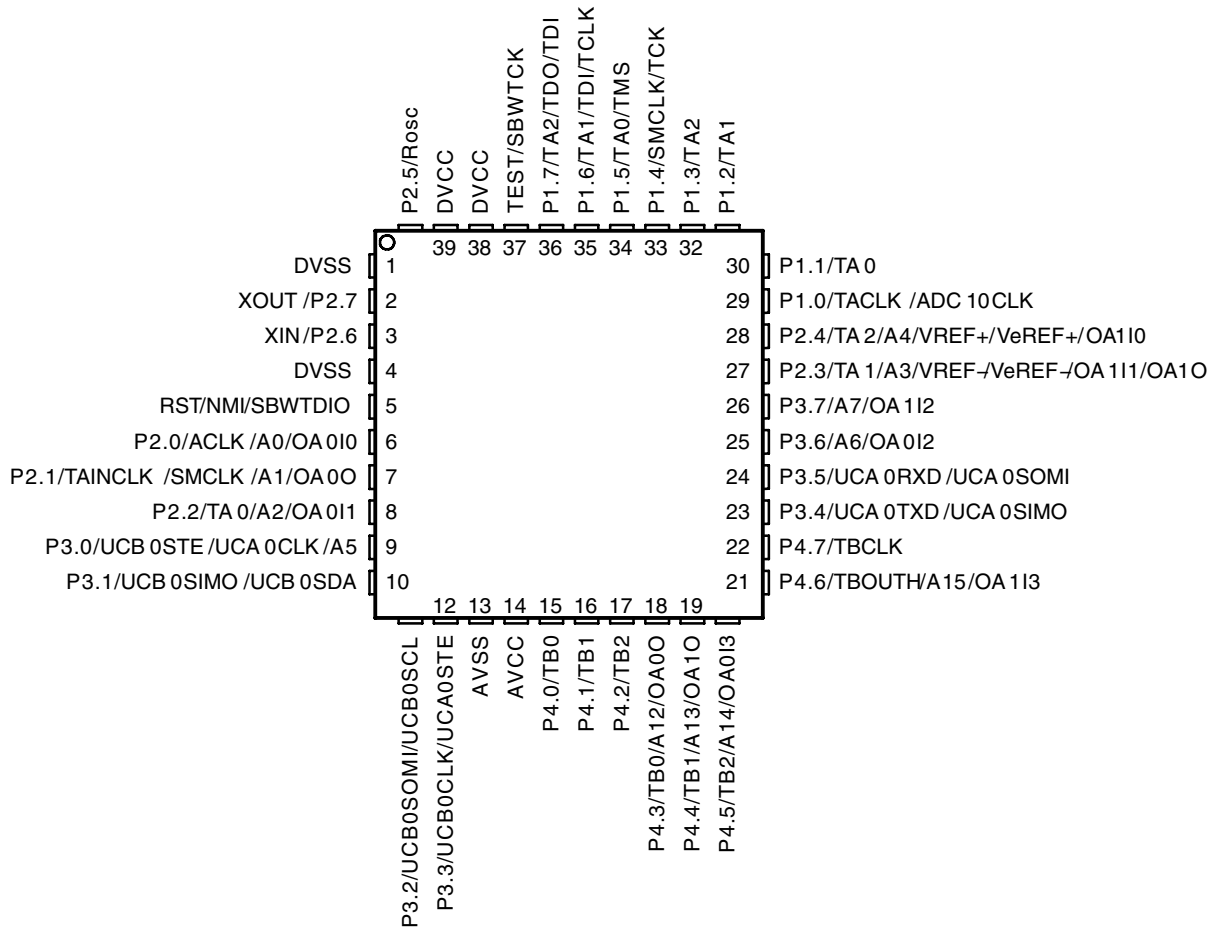

MSP430x22x2, MSP430x22x4 MIXED SIGNAL MICROCONTROLLER

SLAS504B – JULY 2006 – REVISED JULY 2007

MSP430x22x2 functional block diagram

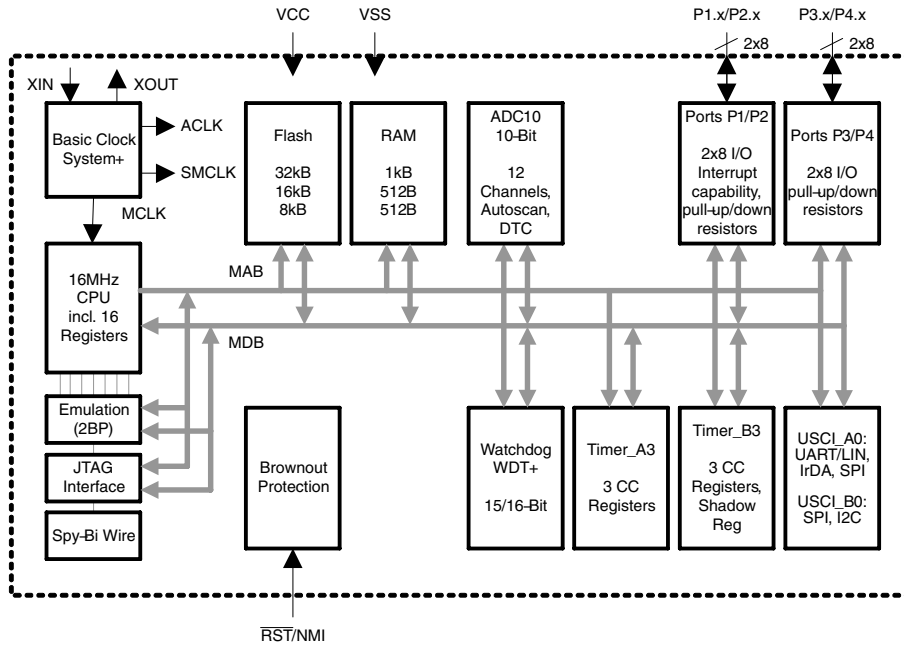

NOTE: See port schematics section for detailed I/O information.

MSP430x22x4 functional block diagram

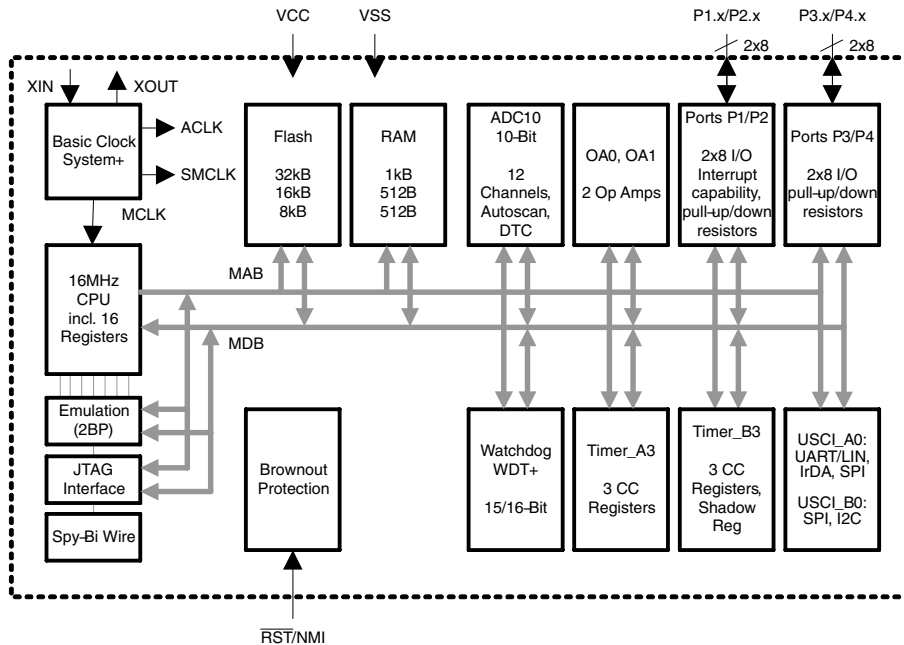

NOTE: See port schematics section for detailed I/O information.



MSP430x22x2, MSP430x22x4 MIXED SIGNAL MICROCONTROLLER

SLAS504B – JULY 2006 – REVISED JULY 2007

Terminal Functions, MSP430x22x2

| TERMINAL | | | | DESCRIPTION |
|--|--------|---------|-----|---|
| NAME | DA NO. | RHA NO. | I/O | |
| P1.0/TACLK/ ADC10CLK | 31 | 29 | I/O | General-purpose digital I/O pin Timer_A, clock signal TACLK input ADC10, conversion clock |
| P1.1/TA0 | 32 | 30 | I/O | General-purpose digital I/O pin Timer_A, capture: CCI0A input, compare: OUT0 output/BSL transmit |
| P1.2/TA1 | 33 | 31 | I/O | General-purpose digital I/O pin Timer_A, capture: CCI1A input, compare: OUT1 output |
| P1.3/TA2 | 34 | 32 | I/O | General-purpose digital I/O pin Timer_A, capture: CCI2A input, compare: OUT2 output |
| P1.4/SMCLK/ TCK | 35 | 33 | I/O | General-purpose digital I/O pin / SMCLK signal output Test Clock input for device programming and test |
| P1.5/TA0/ TMS | 36 | 34 | I/O | General-purpose digital I/O pin / Timer_A, compare: OUT0 output Test Mode Select input for device programming and test |
| P1.6/TA1/ TDI/TCLK | 37 | 35 | I/O | General-purpose digital I/O pin / Timer_A, compare: OUT1 output Test Data Input or Test Clock Input for programming and test |
| P1.7/TA2/ TDO/TDI† | 38 | 36 | I/O | General-purpose digital I/O pin / Timer_A, compare: OUT2 output Test Data Output or Test Data Input for programming and test |
| P2.0/ACLK/A0 | 8 | 6 | I/O | General-purpose digital I/O pin / ACLK output ADC10, analog input A0 |
| P2.1/TAINCLK/SMCLK/A1 | 9 | 7 | I/O | General-purpose digital I/O pin Timer_A, clock signal at INCLK, SMCLK signal output ADC10, analog input A1 |
| P2.2/TA0/A2 | 10 | 8 | I/O | General-purpose digital I/O pin Timer_A, capture: CCI0B input/BSL receive, compare: OUT0 output ADC10, analog input A2 |
| P2.3/TA1/ A3/V _{REF-} /V _{REF-} | 29 | 27 | I/O | General-purpose digital I/O pin Timer_A, capture CCI1B input, compare: OUT1 output ADC10, analog input A3 / negative reference voltage output/input |
| P2.4/TA2/ A4/V _{REF+} /V _{REF+} | 30 | 28 | I/O | General-purpose digital I/O pin / Timer_A, compare: OUT2 output ADC10, analog input A4 / positive reference voltage output/input |
| P2.5/ R _{OSC} | 3 | 40 | I/O | General-purpose digital I/O pin Input for external DCO resistor to define DCO frequency |
| XIN/P2.6 | 6 | 3 | I/O | Input terminal of crystal oscillator General-purpose digital I/O pin |
| XOUT/P2.7 | 5 | 2 | I/O | Output terminal of crystal oscillator General-purpose digital I/O pin |
| P3.0/ UCB0STE/UCA0CLK/ A5 | 11 | 9 | I/O | General-purpose digital I/O pin USCI_B0 slave transmit enable / USCI_A0 clock input/output ADC10, analog input A5 |
| P3.1/ UCB0SIMO/UCB0SDA | 12 | 10 | I/O | General-purpose digital I/O pin USCI_B0 slave in/master out in SPI mode, SDA I ² C data in I ² C mode |
| P3.2/ UCB0SOMI/UCB0SCL | 13 | 11 | I/O | General-purpose digital I/O pin USCI_B0 slave out/master in in SPI mode, SCL I ² C clock in I ² C mode |
| P3.3/ UCB0CLK/UCA0STE | 14 | 12 | I/O | General-purpose digital I/O pin USCI_B0 clock input/output / USCI_A0 slave transmit enable |
| P3.4/ UCA0TXD/UCA0SIMO | 25 | 23 | I/O | General-purpose digital I/O pin USCI_A0 transmit data output in UART mode, slave in/master out in SPI mode |



MSP430x22x2, MSP430x22x4 MIXED SIGNAL MICROCONTROLLER

SLAS504B – JULY 2006 – REVISED JULY 2007

Terminal Functions, MSP430x22x2 (Continued)

| TERMINAL | | | | DESCRIPTION |
|---------------------------|--------|-------------|-----|--|
| NAME | DA NO. | RHA NO. | I/O | |
| P3.5/ UCA0RXD/UCA0SOMI | 26 | 24 | I/O | General-purpose digital I/O pin USCI_A0 receive data input in UART mode, slave out/master in in SPI mode |
| P3.6/A6 | 27 | 25 | I/O | General-purpose digital I/O pin ADC10 analog input A6 |
| P3.7/A7 | 28 | 26 | I/O | General-purpose digital I/O pin ADC10 analog input A7 |
| P4.0/TB0 | 17 | 15 | I/O | General-purpose digital I/O pin Timer_B, capture: CCI0A input, compare: OUT0 output |
| P4.1/TB1 | 18 | 16 | I/O | General-purpose digital I/O pin Timer_B, capture: CCI1A input, compare: OUT1 output |
| P4.2/TB2 | 19 | 17 | I/O | General-purpose digital I/O pin Timer_B, capture: CCI2A input, compare: OUT2 output |
| P4.3/TB0/ A12 | 20 | 18 | I/O | General-purpose digital I/O pin Timer_B, capture: CCI0B input, compare: OUT0 output ADC10 analog input A12 |
| P4.4/TB1 A13 | 21 | 19 | I/O | General-purpose digital I/O pin Timer_B, capture: CCI1B input, compare: OUT1 output ADC10 analog input A13 |
| P4.5/TB2 A14 | 22 | 20 | I/O | General-purpose digital I/O pin Timer_B, compare: OUT2 output ADC10 analog input A14 |
| P4.6/TBOUTH A15 | 23 | 21 | I/O | General-purpose digital I/O pin Timer_B, switch all TB0 to TB3 outputs to high impedance ADC10 analog input A15 |
| P4.7/TBCLK | 24 | 22 | I/O | General-purpose digital I/O pin Timer_B, clock signal TBCLK input |
| RST/NMI/SBWTIO | 7 | 5 | I | Reset or nonmaskable interrupt input Spy-Bi-Wire test data input/output during programming and test |
| TEST/SBWTCK | 1 | 37 | I | Selects test mode for JTAG pins on Port1. The device protection fuse is connected to TEST. Spy-Bi-Wire test clock input during programming and test |
| DV _{CC} | 2 | 38, 39 | | Digital supply voltage |
| AV _{CC} | 16 | 14 | | Analog supply voltage |
| DV _{SS} | 4 | 1, 4 | | Digital ground reference |
| AV _{SS} | 15 | 13 | | Analog ground reference |
| QFN Pad | NA | Package Pad | NA | QFN package pad; connection to DV _{SS} recommended. |

† TDO or TDI is selected via JTAG instruction.

NOTE: If XOUT/P2.7/CA7 is used as an input, excess current will flow until P2SEL.7 is cleared. This is due to the oscillator output driver connection to this pad after reset.



Terminal Functions, MSP430x22x4

| TERMINAL | | | | DESCRIPTION |
|--|--------|---------|-----|--|
| NAME | DA NO. | RHA NO. | I/O | |
| P1.0/TACLK/ ADC10CLK | 31 | 29 | I/O | General-purpose digital I/O pin Timer_A, clock signal TACLK input ADC10, conversion clock |
| P1.1/TA0 | 32 | 30 | I/O | General-purpose digital I/O pin Timer_A, capture: CCI0A input, compare: OUT0 output/BSL transmit |
| P1.2/TA1 | 33 | 31 | I/O | General-purpose digital I/O pin Timer_A, capture: CCI1A input, compare: OUT1 output |
| P1.3/TA2 | 34 | 32 | I/O | General-purpose digital I/O pin Timer_A, capture: CCI2A input, compare: OUT2 output |
| P1.4/SMCLK/ TCK | 35 | 33 | I/O | General-purpose digital I/O pin / SMCLK signal output Test Clock input for device programming and test |
| P1.5/TA0/ TMS | 36 | 34 | I/O | General-purpose digital I/O pin / Timer_A, compare: OUT0 output Test Mode Select input for device programming and test |
| P1.6/TA1/ TDI/TCLK | 37 | 35 | I/O | General-purpose digital I/O pin / Timer_A, compare: OUT1 output Test Data Input or Test Clock Input for programming and test |
| P1.7/TA2/ TDO/TDI† | 38 | 36 | I/O | General-purpose digital I/O pin / Timer_A, compare: OUT2 output Test Data Output or Test Data Input for programming and test |
| P2.0/ACLK/A0/OA0I0 | 8 | 6 | I/O | General-purpose digital I/O pin / ACLK output ADC10, analog input A0 / OA0, analog input I0 |
| P2.1/TAINCLK/SMCLK/ A1/OA0O | 9 | 7 | I/O | General-purpose digital I/O pin / Timer_A, clock signal at INCLK SMCLK signal output ADC10, analog input A1 / OA0, analog output |
| P2.2/TA0/ A2/OA0I1 | 10 | 8 | I/O | General-purpose digital I/O pin Timer_A, capture: CCI0B input/BSL receive, compare: OUT0 output ADC10, analog input A2 / OA0, analog input I1 |
| P2.3/TA1/ A3/V _{REF-} /V _{REF-} / OA1I1/OA1O | 29 | 27 | I/O | General-purpose digital I/O pin Timer_A, capture CCI1B input, compare: OUT1 output ADC10, analog input A3 / negative reference voltage output/input OA1, analog input I1 / OA1, analog output |
| P2.4/TA2/ A4/V _{REF+} /V _{REF+} / OA1I0 | 30 | 28 | I/O | General-purpose digital I/O pin / Timer_A, compare: OUT2 output ADC10, analog input A4 / positive reference voltage output/input OA1, analog input I0 |
| P2.5/ R _{OSC} | 3 | 40 | I/O | General-purpose digital I/O pin Input for external DCO resistor to define DCO frequency |
| XIN/P2.6 | 6 | 3 | I/O | Input terminal of crystal oscillator General-purpose digital I/O pin |
| XOUT/P2.7 | 5 | 2 | I/O | Output terminal of crystal oscillator General-purpose digital I/O pin |
| P3.0/ UCB0STE/UCA0CLK/ A5 | 11 | 9 | I/O | General-purpose digital I/O pin USCI_B0 slave transmit enable / USCI_A0 clock input/output ADC10, analog input A5 |
| P3.1/ UCB0SIMO/UCB0SDA | 12 | 10 | I/O | General-purpose digital I/O pin USCI_B0 slave in/master out in SPI mode, SDA I ² C data in I ² C mode |
| P3.2/ UCB0SOMI/UCB0SCL | 13 | 11 | I/O | General-purpose digital I/O pin USCI_B0 slave out/master in in SPI mode, SCL I ² C clock in I ² C mode |
| P3.3/ UCB0CLK/UCA0STE | 14 | 12 | I/O | General-purpose digital I/O pin USCI_B0 clock input/output / USCI_A0 slave transmit enable |
| P3.4/ UCA0TXD/UCA0SIMO | 25 | 23 | I/O | General-purpose digital I/O pin USCI_A0 transmit data output in UART mode, slave in/master out in SPI mode |



MSP430x22x2, MSP430x22x4 MIXED SIGNAL MICROCONTROLLER

SLAS504B – JULY 2006 – REVISED JULY 2007

Terminal Functions, MSP430x22x4 (Continued)

| TERMINAL | | | | DESCRIPTION |
|---------------------------|--------|-------------|-----|--|
| NAME | DA NO. | RHA NO. | I/O | |
| P3.5/ UCA0RXD/UCA0SOMI | 26 | 24 | I/O | General-purpose digital I/O pin USCI_A0 receive data input in UART mode, slave out/master in in SPI mode |
| P3.6/A6/OA0I2 | 27 | 25 | I/O | General-purpose digital I/O pin ADC10 analog input A6 / OA0 analog input I2 |
| P3.7/A7/OA1I2 | 28 | 26 | I/O | General-purpose digital I/O pin ADC10 analog input A7 / OA1 analog input I2 |
| P4.0/TB0 | 17 | 15 | I/O | General-purpose digital I/O pin Timer_B, capture: CCI0A input, compare: OUT0 output |
| P4.1/TB1 | 18 | 16 | I/O | General-purpose digital I/O pin Timer_B, capture: CCI1A input, compare: OUT1 output |
| P4.2/TB2 | 19 | 17 | I/O | General-purpose digital I/O pin Timer_B, capture: CCI2A input, compare: OUT2 output |
| P4.3/TB0/ A12/OA0O | 20 | 18 | I/O | General-purpose digital I/O pin Timer_B, capture: CCI0B input, compare: OUT0 output ADC10 analog input A12 / OA0 analog output |
| P4.4/TB1 A13/OA1O | 21 | 19 | I/O | General-purpose digital I/O pin Timer_B, capture: CCI1B input, compare: OUT1 output ADC10 analog input A13 / OA1 analog output |
| P4.5/TB2 A14/OA0I3 | 22 | 20 | I/O | General-purpose digital I/O pin Timer_B, compare: OUT2 output ADC10 analog input A14 / OA0 analog input I3 |
| P4.6/TBOUTH A15/OA1I3 | 23 | 21 | I/O | General-purpose digital I/O pin Timer_B, switch all TB0 to TB3 outputs to high impedance ADC10 analog input A15 / OA1 analog input I3 |
| P4.7/TBCLK | 24 | 22 | I/O | General-purpose digital I/O pin Timer_B, clock signal TBCLK input |
| RST/NMI/SBWTIO | 7 | 5 | I | Reset or nonmaskable interrupt input Spy-Bi-Wire test data input/output during programming and test |
| TEST/SBWTCK | 1 | 37 | I | Selects test mode for JTAG pins on Port1. The device protection fuse is connected to TEST. Spy-Bi-Wire test clock input during programming and test |
| DV _{CC} | 2 | 38, 39 | | Digital supply voltage |
| AV _{CC} | 16 | 14 | | Analog supply voltage |
| DV _{SS} | 4 | 1, 4 | | Digital ground reference |
| AV _{SS} | 15 | 13 | | Analog ground reference |
| QFN Pad | NA | Package Pad | NA | QFN package pad connection to DV _{SS} recommended. |

† TDO or TDI is selected via JTAG instruction.

NOTE: If XOUT/P2.7/CA7 is used as an input, excess current will flow until P2SEL.7 is cleared. This is due to the oscillator output driver connection to this pad after reset.



short-form description

CPU

The MSP430 CPU has a 16-bit RISC architecture that is highly transparent to the application. All operations, other than program-flow instructions, are performed as register operations in conjunction with seven addressing modes for source operand and four addressing modes for destination operand.

The CPU is integrated with 16 registers that provide reduced instruction execution time. The register-to-register operation execution time is one cycle of the CPU clock.

Four of the registers, R0 to R3, are dedicated as program counter, stack pointer, status register, and constant generator respectively. The remaining registers are general-purpose registers.

Peripherals are connected to the CPU using data, address, and control buses, and can be handled with all instructions.

| | |
|--------------------------|-----------|
| Program Counter | PC/R0 |
| Stack Pointer | SP/R1 |
| Status Register | SR/CG1/R2 |
| Constant Generator | CG2/R3 |
| General-Purpose Register | R4 |
| General-Purpose Register | R5 |
| General-Purpose Register | R6 |
| General-Purpose Register | R7 |
| General-Purpose Register | R8 |
| General-Purpose Register | R9 |
| General-Purpose Register | R10 |
| General-Purpose Register | R11 |
| General-Purpose Register | R12 |
| General-Purpose Register | R13 |
| General-Purpose Register | R14 |
| General-Purpose Register | R15 |

instruction set

The instruction set consists of 51 instructions with three formats and seven address modes. Each instruction can operate on word and byte data. Table 1 shows examples of the three types of instruction formats; the address modes are listed in Table 2.

Table 1. Instruction Word Formats

| | | |
|-----------------------------------|-----------------|------------------------|
| Dual operands, source-destination | e.g., ADD R4,R5 | R4 + R5 ----> R5 |
| Single operands, destination only | e.g., CALL R8 | PC --> (TOS), R8--> PC |
| Relative jump, un/conditional | e.g., JNE | Jump-on-equal bit = 0 |

Table 2. Address Mode Descriptions

| ADDRESS MODE | S | D | SYNTAX | EXAMPLE | OPERATION |
|------------------------|---|---|-----------------|------------------|----------------------------------|
| Register | ● | ● | MOV Rs,Rd | MOV R10,R11 | R10 --> R11 |
| Indexed | ● | ● | MOV X(Rn),Y(Rm) | MOV 2(R5),6(R6) | M(2+R5)--> M(6+R6) |
| Symbolic (PC relative) | ● | ● | MOV EDE,TONI | | M(EDE) --> M(TONI) |
| Absolute | ● | ● | MOV &MEM,&TCDAT | | M(MEM) --> M(TCDAT) |
| Indirect | ● | | MOV @Rn,Y(Rm) | MOV @R10,Tab(R6) | M(R10) --> M(Tab+R6) |
| Indirect autoincrement | ● | | MOV @Rn+,Rm | MOV @R10+,R11 | M(R10) --> R11 R10 + 2--> R10 |
| Immediate | ● | | MOV #X,TONI | MOV #45,TONI | #45 --> M(TONI) |

NOTE: S = source D = destination



MSP430x22x2, MSP430x22x4 MIXED SIGNAL MICROCONTROLLER

SLAS504B – JULY 2006 – REVISED JULY 2007

operating modes

The MSP430 has one active mode and five software selectable low-power modes of operation. An interrupt event can wake up the device from any of the five low-power modes, service the request, and restore back to the low-power mode on return from the interrupt program.

The following six operating modes can be configured by software:

- Active mode (AM)
 - All clocks are active
- Low-power mode 0 (LPM0)
 - CPU is disabled
ACLK and SMCLK remain active
MCLK is disabled
- Low-power mode 1 (LPM1)
 - CPU is disabled
ACLK and SMCLK remain active
MCLK is disabled
DCO's dc-generator is disabled if DCO not used in active mode
- Low-power mode 2 (LPM2)
 - CPU is disabled
MCLK and SMCLK are disabled
DCO's dc-generator remains enabled
ACLK remains active
- Low-power mode 3 (LPM3)
 - CPU is disabled
MCLK and SMCLK are disabled
DCO's dc-generator is disabled
ACLK remains active
- Low-power mode 4 (LPM4)
 - CPU is disabled
ACLK is disabled
MCLK and SMCLK are disabled
DCO's dc-generator is disabled
Crystal oscillator is stopped



POST OFFICE BOX 655303 • DALLAS, TEXAS 75265
POST OFFICE BOX 1443 • HOUSTON, TEXAS 77251-1443

interrupt vector addresses

The interrupt vectors and the power-up starting address are located in the address range of 0FFFFh to 0FFC0h. The vector contains the 16-bit address of the appropriate interrupt handler instruction sequence.

If the reset vector (located at address 0FFFEh) contains 0FFFFh (e.g., flash is not programmed) the CPU goes into LPM4 immediately after power up.

| INTERRUPT SOURCE | INTERRUPT FLAG | SYSTEM INTERRUPT | WORD ADDRESS | PRIORITY |
|---|--|--|-------------------|------------------|
| Power-up External reset Watchdog Flash key violation PC out-of-range (see Note 1) | PORIFG RSTIFG WDTIFG KEYV (see Note 2) | Reset | 0FFFEh | 31, highest |
| NMI Oscillator fault Flash memory access violation | NMIIFG OFIFG ACCVIFG (see Notes 2 & 4) | (non)-maskable, (non)-maskable, (non)-maskable | 0FFFCh | 30 |
| Timer_B3 | TBCCR0 CCIFG (see Note 3) | maskable | 0FFFAh | 29 |
| Timer_B3 | TBCCR1 and TBCCR2 CCIFGs, TBIFG (see Notes 2 and 3) | maskable | 0FFF8h | 28 |
| | | | 0FFF6h | 27 |
| Watchdog Timer | WDTIFG | maskable | 0FFF4h | 26 |
| Timer_A3 | TACCR0 CCIFG (see Note 3) | maskable | 0FFF2h | 25 |
| Timer_A3 | TACCR1 CCIFG. TACCR2 CCIFG TAIFG (see Notes 2 and 3) | maskable | 0FFF0h | 24 |
| USCI_A0/USCI_B0 Receive | UCA0RXIFG, UCB0RXIFG (see Notes 2) | maskable | 0FFEEh | 23 |
| USCI_A0/USCI_B0 Transmit | UCA0TXIFG, UCB0TXIFG (see Notes 2) | maskable | 0FFECh | 22 |
| ADC10 | ADC10IFG (see Note 3) | maskable | 0FFEAh | 21 |
| | | | 0FFE8h | 20 |
| I/O Port P2 (eight flags) | P2IFG.0 to P2IFG.7 (see Notes 2 and 3) | maskable | 0FFE6h | 19 |
| I/O Port P1 (eight flags) | P1IFG.0 to P1IFG.7 (see Notes 2 and 3) | maskable | 0FFE4h | 18 |
| | | | 0FFE2h | 17 |
| | | | 0FFE0h | 16 |
| (see Note 5) | | | 0FFDEh | 15 |
| (see Note 6) | | | 0FFDCh ... 0FFC0h | 14 ... 0, lowest |

- NOTES:
1. A reset is generated if the CPU tries to fetch instructions from within the module register memory address range (0h–01FFh) or from within unused address ranges.
 2. Multiple source flags
 3. Interrupt flags are located in the module.
 4. (non)-maskable: the individual interrupt-enable bit can disable an interrupt event, but the general interrupt enable cannot. Nonmaskable: neither the individual nor the general interrupt-enable bit will disable an interrupt event.
 5. This location is used as bootstrap loader security key (BSLSKEY).
A 0AA55h at this location disables the BSL completely.
A zero (0h) disables the erasure of the flash if an invalid password is supplied.
 6. The interrupt vectors at addresses 0FFDCh to 0FFC0h are not used in this device and can be used for regular program code if necessary.



MSP430x22x2, MSP430x22x4 MIXED SIGNAL MICROCONTROLLER

SLAS504B – JULY 2006 – REVISED JULY 2007

special function registers

Most interrupt and module enable bits are collected into the lowest address space. Special function register bits not allocated to a functional purpose are not physically present in the device. Simple software access is provided with this arrangement.

interrupt enable 1 and 2

| Address | 7 | 6 | 5 | 4 | 3 | 2 | 1 | 0 |
|---------|---|---|--------|-------|---|---|------|-------|
| 00h | | | ACCVIE | NMIIE | | | OFIE | WDTIE |
| | | | rw-0 | rw-0 | | | rw-0 | rw-0 |

- WDTIE Watchdog Timer interrupt enable. Inactive if watchdog mode is selected. Active if Watchdog Timer is configured in interval timer mode.
- OFIE Oscillator fault enable
- NMIIE (Non)-maskable interrupt enable
- ACCVIE Flash access violation interrupt enable

| Address | 7 | 6 | 5 | 4 | 3 | 2 | 1 | 0 |
|---------|---|---|---|---|----------|----------|----------|----------|
| 01h | | | | | UCB0TXIE | UCB0RXIE | UCA0TXIE | UCA0RXIE |
| | | | | | rw-0 | rw-0 | rw-0 | rw-0 |

- UCA0RXIE USCI_A0 receive-interrupt enable
- UCA0TXIE USCI_A0 transmit-interrupt enable
- UCB0RXIE USCI_B0 receive-interrupt enable
- UCB0TXIE USCI_B0 transmit-interrupt enable



interrupt flag register 1 and 2

| Address | 7 | 6 | 5 | 4 | 3 | 2 | 1 | 0 |
|---------|---|---|---|--------|--------|--------|-------|--------|
| 02h | | | | NMIIFG | RSTIFG | PORIFG | OFIFG | WDTIFG |
| | | | | rw-0 | rw-(0) | rw-(1) | rw-1 | rw-(0) |

- WDTIFG Set on Watchdog Timer overflow (in watchdog mode) or security key violation. Reset on V_{CC} power up or a reset condition at $\overline{\text{RST}}$ /NMI pin in reset mode.
- OFIFG Flag set on oscillator fault
- RSTIFG External reset interrupt flag. Set on a reset condition at $\overline{\text{RST}}$ /NMI pin in reset mode. Reset on V_{CC} power up.
- PORIFG Power-On interrupt flag. Set on V_{CC} power up.
- NMIIFG Set via $\overline{\text{RST}}$ /NMI-pin

| Address | 7 | 6 | 5 | 4 | 3 | 2 | 1 | 0 |
|---------|---|---|---|---|---------------|---------------|---------------|---------------|
| 03h | | | | | UCB0 TXIFG | UCB0 RXIFG | UCA0 TXIFG | UCA0 RXIFG |
| | | | | | rw-1 | rw-0 | rw-1 | rw-0 |

- UCA0RXIFG USCI_A0 receive-interrupt flag
- UCA0TXIFG USCI_A0 transmit-interrupt flag
- UCB0RXIFG USCI_B0 receive-interrupt flag
- UCB0TXIFG USCI_B0 transmit-interrupt flag

- Legend** **rw:** Bit can be read and written.
- rw-0,1:** Bit can be read and written. It is reset or set by PUC.
- rw-(0,1):** Bit can be read and written. It is reset or set by POR.
- SFR bit is not present in device.

MSP430x22x2, MSP430x22x4 MIXED SIGNAL MICROCONTROLLER

SLAS504B – JULY 2006 – REVISED JULY 2007

memory organization

| | | MSP430F223x | MSP430F225x | MSP430F227x |
|---|-----------|--------------------------------|--------------------------------|--------------------------------|
| Memory Main: interrupt vector Main: code memory | Size | 8KB Flash | 16KB Flash | 32KB Flash |
| | Flash | 0FFFFh–0FFC0h 0FFFFh–0E000h | 0FFFFh–0FFC0h 0FFFFh–0C000h | 0FFFFh–0FFC0h 0FFFFh–08000h |
| Information memory | Size | 256 Byte | 256 Byte | 256 Byte |
| | Flash | 010FFh–01000h | 010FFh–01000h | 010FFh–01000h |
| Boot memory | Size | 1KB | 1KB | 1KB |
| | ROM | 0FFFh–0C00h | 0FFFh–0C00h | 0FFFh–0C00h |
| RAM | Size | 512 Byte | 512 Byte | 1KB |
| | | 03FFh–0200h | 03FFh–0200h | 05FFh–0200h |
| Peripherals | 16-bit | 01FFh–0100h | 01FFh–0100h | 01FFh–0100h |
| | 8-bit | 0FFh–010h | 0FFh–010h | 0FFh–010h |
| | 8-bit SFR | 0Fh–00h | 0Fh–00h | 0Fh–00h |

bootstrap loader (BSL)

The MSP430 bootstrap loader (BSL) enables users to program the flash memory or RAM using a UART serial interface. Access to the MSP430 memory via the BSL is protected by user-defined password. For complete description of the features of the BSL and its implementation, see the application report, *Features of the MSP430 Bootstrap Loader*, TI literature number SLAA089.

| BSL Function | DA Package Pins | RHA Package Pins |
|---------------|-----------------|------------------|
| Data transmit | 32 - P1.1 | 30 - P1.1 |
| Data receive | 10 - P2.2 | 8 - P2.2 |

flash memory

The flash memory can be programmed via the JTAG port, the bootstrap loader, or in-system by the CPU. The CPU can perform single-byte and single-word writes to the flash memory. Features of the flash memory include:

- Flash memory has n segments of main memory and four segments of information memory (A to D) of 64 bytes each. Each segment in main memory is 512 bytes in size.
- Segments 0 to n may be erased in one step, or each segment may be individually erased.
- Segments A to D can be erased individually, or as a group with segments 0–n. Segments A to D are also called *information memory*.
- Segment A contains calibration data. After reset, segment A is protected against programming or erasing. It can be unlocked, but care should be taken not to erase this segment if the calibration data is required.



peripherals

Peripherals are connected to the CPU through data, address, and control busses and can be handled using all instructions. For complete module descriptions, refer to the *MSP430x2xx Family User's Guide*.

oscillator and system clock

The clock system is supported by the basic clock module that includes support for a 32768-Hz watch crystal oscillator, an internal very low power, low frequency oscillator, an internal digitally-controlled oscillator (DCO), and a high frequency crystal oscillator. The basic clock module is designed to meet the requirements of both low system cost and low power consumption. The internal DCO provides a fast turn-on clock source and stabilizes in less than 1 μ s. The basic clock module provides the following clock signals:

- Auxiliary clock (ACLK), sourced from a 32768-Hz watch crystal, a high frequency crystal, or the internal very low power LF oscillator.
- Main clock (MCLK), the system clock used by the CPU.
- Sub-Main clock (SMCLK), the sub-system clock used by the peripheral modules.

| DCO Calibration Data (provided from factory in flash info memory segment A) | | | |
|---|----------------------|------|---------|
| DCO Frequency | Calibration Register | Size | Address |
| 1 MHz | CALBC1_1MHZ | byte | 010FFh |
| | CALDCO_1MHZ | byte | 010FEh |
| 8 MHz | CALBC1_8MHZ | byte | 010FDh |
| | CALDCO_8MHZ | byte | 010FCh |
| 12 MHz | CALBC1_12MHZ | byte | 010FBh |
| | CALDCO_12MHZ | byte | 010FAh |
| 16 MHz | CALBC1_16MHZ | byte | 010F9h |
| | CALDCO_16MHZ | byte | 010F8h |

brownout

The brownout circuit is implemented to provide the proper internal reset signal to the device during power on and power off.

digital I/O

There are four 8-bit I/O ports implemented—ports P1, P2, P3, and P4:

- All individual I/O bits are independently programmable.
- Any combination of input, output, and interrupt conditions is possible.
- Edge-selectable interrupt input capability for all the eight bits of port P1 and P2.
- Read/write access to port-control registers is supported by all instructions.
- Each I/O has an individually programmable pullup/pulldown resistor.

watchdog timer (WDT+)

The primary function of the WDT+ module is to perform a controlled system restart after a software problem occurs. If the selected time interval expires, a system reset is generated. If the watchdog function is not needed in an application, the module can be configured as an interval timer and can generate interrupts at selected time intervals.



MSP430x22x2, MSP430x22x4 MIXED SIGNAL MICROCONTROLLER

SLAS504B – JULY 2006 – REVISED JULY 2007

timer_A3

Timer_A3 is a 16-bit timer/counter with three capture/compare registers. Timer_A3 can support multiple capture/compares, PWM outputs, and interval timing. Timer_A3 also has extensive interrupt capabilities. Interrupts may be generated from the counter on overflow conditions and from each of the capture/compare registers.

| Timer_A3 Signal Connections | | | | | | | |
|-----------------------------|-----------|---------------------|-------------------|--------------|----------------------|-------------------|-----------|
| Input Pin Number | | Device Input Signal | Module Input Name | Module Block | Module Output Signal | Output Pin Number | |
| DA | RHA | | | | | DA | RHA |
| 31 - P1.0 | 29 - P1.0 | TACLK | TACLK | Timer | NA | | |
| | | ACLK | ACLK | | | | |
| | | SMCLK | SMCLK | | | | |
| 9 - P2.1 | 7 - P2.1 | TAINCLK | INCLK | | | | |
| 32 - P1.1 | 30 - P1.1 | TA0 | CCI0A | CCR0 | TA0 | 32 - P1.1 | 30 - P1.1 |
| 10 - P2.2 | 8 - P2.2 | TA0 | CCI0B | | | 10 - P2.2 | 8 - P2.2 |
| | | V _{SS} | GND | | | 36 - P1.5 | 34 - P1.5 |
| | | V _{CC} | V _{CC} | | | | |
| 33 - P1.2 | 31 - P1.2 | TA1 | CCI1A | CCR1 | TA1 | 33 - P1.2 | 31 - P1.2 |
| 29 - P2.3 | 27 - P2.3 | TA1 | CCI1B | | | 29 - P2.3 | 27 - P2.3 |
| | | V _{SS} | GND | | | 37 - P1.6 | 35 - P1.6 |
| | | V _{CC} | V _{CC} | | | | |
| 34 - P1.3 | 32 - P1.3 | TA2 | CCI2A | CCR2 | TA2 | 34 - P1.3 | 32 - P1.3 |
| | | ACLK (internal) | CCI2B | | | 30 - P2.4 | 28 - P2.4 |
| | | V _{SS} | GND | | | 38 - P1.7 | 36 - P1.7 |
| | | V _{CC} | V _{CC} | | | | |



timer_B3

Timer_B3 is a 16-bit timer/counter with three capture/compare registers. Timer_B3 can support multiple capture/compares, PWM outputs, and interval timing. Timer_B3 also has extensive interrupt capabilities. Interrupts may be generated from the counter on overflow conditions and from each of the capture/compare registers.

| Timer_B3 Signal Connections | | | | | | | |
|-----------------------------|-----------|---------------------|-------------------|--------------|----------------------|-------------------|-----------|
| Input Pin Number | | Device Input Signal | Module Input Name | Module Block | Module Output Signal | Output Pin Number | |
| DA | RHA | | | | | DA | RHA |
| 24 - P4.7 | 22 - P4.7 | TBCLK | TBCLK | Timer | NA | | |
| | | ACLK | ACLK | | | | |
| | | SMCLK | SMCLK | | | | |
| 24 - P4.7 | 22 - P4.7 | TBCLK | INCLK | | | | |
| 17 - P4.0 | 15 - P4.0 | TB0 | CCI0A | CCR0 | TB0 | 17 - P4.0 | 15 - P4.0 |
| 20 - P4.3 | 18 - P4.3 | TB0 | CCI0B | | | 20 - P4.3 | 18 - P4.3 |
| | | V _{SS} | GND | | | | |
| | | V _{CC} | V _{CC} | | | | |
| 18 - P4.1 | 16 - P4.1 | TB1 | CCI1A | CCR1 | TB1 | 18 - P4.1 | 16 - P4.1 |
| 21 - P4.4 | 19 - P4.4 | TB1 | CCI1B | | | 21 - P4.4 | 19 - P4.4 |
| | | V _{SS} | GND | | | | |
| | | V _{CC} | V _{CC} | | | | |
| 19 - P4.2 | 17 - P4.2 | TB2 | CCI2A | CCR2 | TB2 | 19 - P4.2 | 17 - P4.2 |
| | | ACLK (internal) | CCI2B | | | 22 - P4.5 | 20 - P4.5 |
| | | V _{SS} | GND | | | | |
| | | V _{CC} | V _{CC} | | | | |

universal serial communications interface (USCI)

The USCI module is used for serial data communication. The USCI module supports synchronous communication protocols like SPI (3 or 4 pin), I²C and asynchronous communication protocols such as UART, enhanced UART with automatic baudrate detection (LIN), and IrDA.

USCI_A0 provides support for SPI (3 or 4 pin), UART, enhanced UART, and IrDA.

USCI_B0 provides support for SPI (3 or 4 pin) and I²C.

MSP430x22x2, MSP430x22x4 MIXED SIGNAL MICROCONTROLLER

SLAS504B – JULY 2006 – REVISED JULY 2007

ADC10

The ADC10 module supports fast, 10-bit analog-to-digital conversions. The module implements a 10-bit SAR core, sample select control, reference generator and data transfer controller, or DTC, for automatic conversion result handling allowing ADC samples to be converted and stored without any CPU intervention.

operational amplifier OA (MSP430x22x4 only)

The MSP430x22x4 has two configurable low-current general-purpose operational amplifiers. Each OA input and output terminal is software-selectable and offer a flexible choice of connections for various applications. The OA op amps primarily support front-end analog signal conditioning prior to analog-to-digital conversion.

| OA0 Signal Connections | | | |
|-------------------------|----------|---------------------|-------------------|
| Analog Input Pin Number | | Device Input Signal | Module Input Name |
| DA | RHA | | |
| 8 - A0 | 6 - A0 | OA0I0 | OAxI0 |
| 10 - A2 | 8 - A2 | OA0I1 | OA0I1 |
| 10 - A2 | 8 - A2 | OA0I1 | OAxI1 |
| 27 - A6 | 25 - A6 | OA0I2 | OAxIA |
| 22 - A14 | 20 - A14 | OA0I3 | OAxIB |

| OA1 Signal Connections | | | |
|-------------------------|----------|---------------------|-------------------|
| Analog Input Pin Number | | Device Input Signal | Module Input Name |
| DA | RHA | | |
| 30 - A4 | 28 - A4 | OA1I0 | OAxI0 |
| 10 - A2 | 8 - A2 | OA0I1 | OA0I1 |
| 29 - A3 | 27 - A3 | OA1I1 | OAxI1 |
| 28 - A7 | 26 - A7 | OA1I2 | OAxIA |
| 23 - A15 | 21 - A15 | OA1I3 | OAxIB |



peripheral file map

| PERIPHERALS WITH WORD ACCESS | | | |
|-------------------------------------|--|------------|-------|
| ADC10 | ADC data transfer start address | ADC10SA | 1BCh |
| | ADC memory | ADC10MEM | 1B4h |
| | ADC control register 1 | ADC10CTL1 | 1B2h |
| | ADC control register 0 | ADC10CTL0 | 1B0h |
| | ADC analog enable 0 | ADC10AE0 | 04Ah |
| | ADC analog enable 1 | ADC10AE1 | 04Bh |
| | ADC data transfer control register 1 | ADC10DTC1 | 049h |
| | ADC data transfer control register 0 | ADC10DTC0 | 048h |
| Timer_B | Capture/compare register | TBCCR2 | 0196h |
| | Capture/compare register | TBCCR1 | 0194h |
| | Capture/compare register | TBCCR0 | 0192h |
| | Timer_B register | TBR | 0190h |
| | Capture/compare control | TBCCTL2 | 0186h |
| | Capture/compare control | TBCCTL1 | 0184h |
| | Capture/compare control | TBCCTL0 | 0182h |
| | Timer_B control | TBCTL | 0180h |
| Timer_B interrupt vector | TBIV | 011Eh | |
| Timer_A | Capture/compare register | TACCR2 | 0176h |
| | Capture/compare register | TACCR1 | 0174h |
| | Capture/compare register | TACCR0 | 0172h |
| | Timer_A register | TAR | 0170h |
| | Capture/compare control | TACCTL2 | 0166h |
| | Capture/compare control | TACCTL1 | 0164h |
| | Capture/compare control | TACCTL0 | 0162h |
| | Timer_A control | TACTL | 0160h |
| Timer_A interrupt vector | TAIV | 012Eh | |
| Flash Memory | Flash control 3 | FCTL3 | 012Ch |
| | Flash control 2 | FCTL2 | 012Ah |
| | Flash control 1 | FCTL1 | 0128h |
| Watchdog Timer+ | Watchdog/timer control | WDTCTL | 0120h |
| PERIPHERALS WITH BYTE ACCESS | | | |
| OA1 (MSP430x22x4 only) | Operational Amplifier 1 control register 1 | OA1CTL1 | 0C3h |
| | Operational Amplifier 1 control register 1 | OA1CTL0 | 0C2h |
| OA0 (MSP430x22x4 only) | Operational Amplifier 0 control register 1 | OA0CTL1 | 0C1h |
| | Operational Amplifier 0 control register 1 | OA0CTL0 | 0C0h |
| USCI_B0 | USCI_B0 transmit buffer | UCB0TXBUF | 06Fh |
| | USCI_B0 receive buffer | UCB0RXBUF | 06Eh |
| | USCI_B0 status | UCB0STAT | 06Dh |
| | USCI_B0 bit rate control 1 | UCB0BR1 | 06Bh |
| | USCI_B0 bit rate control 0 | UCB0BR0 | 06Ah |
| | USCI_B0 control 1 | UCB0CTL1 | 069h |
| | USCI_B0 control 0 | UCB0CTL0 | 068h |
| | USCI_B0 I2C slave address | UCB0SA | 011Ah |
| | USCI_B0 I2C own address | UCB0OA | 0118h |
| USCI_A0 | USCI_A0 transmit buffer | UCA0TXBUF | 067h |
| | USCI_A0 receive buffer | UCA0RXBUF | 066h |
| | USCI_A0 status | UCA0STAT | 065h |
| | USCI_A0 modulation control | UCA0MCTL | 064h |
| | USCI_A0 baud rate control 1 | UCA0BR1 | 063h |
| | USCI_A0 baud rate control 0 | UCA0BR0 | 062h |
| | USCI_A0 control 1 | UCA0CTL1 | 061h |
| | USCI_A0 control 0 | UCA0CTL0 | 060h |
| | USCI_A0 IrDA receive control | UCA0IRRCTL | 05Fh |
| | USCI_A0 IrDA transmit control | UCA0IRTCTL | 05Eh |
| | USCI_A0 auto baud rate control | UCA0ABCTL | 05Dh |



MSP430x22x2, MSP430x22x4 MIXED SIGNAL MICROCONTROLLER

SLAS504B – JULY 2006 – REVISED JULY 2007

| PERIPHERALS WITH BYTE ACCESS (continued) | | | |
|--|---|--|--|
| Basic Clock System+ | Basic clock system control 3 Basic clock system control 2 Basic clock system control 1 DCO clock frequency control | BCSCTL3 BCSCTL2 BCSCTL1 DCOCTL | 053h 058h 057h 056h |
| Port P4 | Port P4 resistor enable Port P4 selection Port P4 direction Port P4 output Port P4 input | P4REN P4SEL P4DIR P4OUT P4IN | 011h 01Fh 01Eh 01Dh 01Ch |
| Port P3 | Port P3 resistor enable Port P3 selection Port P3 direction Port P3 output Port P3 input | P3REN P3SEL P3DIR P3OUT P3IN | 010h 01Bh 01Ah 019h 018h |
| Port P2 | Port P2 resistor enable Port P2 selection Port P2 interrupt enable Port P2 interrupt edge select Port P2 interrupt flag Port P2 direction Port P2 output Port P2 input | P2REN P2SEL P2IE P2IES P2IFG P2DIR P2OUT P2IN | 02Fh 02Eh 02Dh 02Ch 02Bh 02Ah 029h 028h |
| Port P1 | Port P1 resistor enable Port P1 selection Port P1 interrupt enable Port P1 interrupt edge select Port P1 interrupt flag Port P1 direction Port P1 output Port P1 input | P1REN P1SEL P1IE P1IES P1IFG P1DIR P1OUT P1IN | 027h 026h 025h 024h 023h 022h 021h 020h |
| Special Function | SFR interrupt flag 2 SFR interrupt flag 1 SFR interrupt enable 2 SFR interrupt enable 1 | IFG2 IFG1 IE2 IE1 | 003h 002h 001h 000h |



absolute maximum ratings (see Note 1)

| | |
|--|--------------------------|
| Voltage applied at V_{CC} to V_{SS} | -0.3 V to 4.1 V |
| Voltage applied to any pin (see Note 2) | -0.3 V to $V_{CC}+0.3$ V |
| Diode current at any device terminal | ± 2 mA |
| Storage temperature range, T_{stg} (unprogrammed device, see Note 3) | -55°C to 150°C |
| Storage temperature range, T_{stg} (programmed device, see Note 3) | -40°C to 105°C |

- NOTES: 1. Stresses beyond those listed under “absolute maximum ratings” may cause permanent damage to the device. These are stress ratings only, and functional operation of the device at these or any other conditions beyond those indicated under “recommended operating conditions” is not implied. Exposure to absolute-maximum-rated conditions for extended periods may affect device reliability.
2. All voltages referenced to V_{SS} . The JTAG fuse-blow voltage, V_{FB} , is allowed to exceed the absolute maximum rating. The voltage is applied to the TEST pin when blowing the JTAG fuse.
3. Higher temperature may be applied during board soldering process according to the current JEDEC J-STD-020 specification with peak reflow temperatures not higher than classified on the device label on the shipping boxes or reels.

recommended operating conditions

| | | MIN | NOM | MAX | UNIT |
|--|---|-----|-----|------|------|
| Supply voltage during program execution, V_{CC} | | 1.8 | | 3.6 | V |
| Supply voltage during program/erase flash memory, V_{CC} | | 2.2 | | 3.6 | V |
| Supply voltage, V_{SS} | | | 0 | | V |
| Operating free-air temperature, T_A | I version | -40 | | 85 | °C |
| | T version | -40 | | 105 | |
| Processor frequency f_{SYSTEM} (maximum MCLK frequency) (see Notes 1, 2 and Figure 1) | $V_{CC} = 1.8$ V, Duty cycle = 50% $\pm 10\%$ | | dc | 4.15 | MHz |
| | $V_{CC} = 2.7$ V, Duty cycle = 50% $\pm 10\%$ | | dc | 12 | |
| | $V_{CC} \geq 3.3$ V, Duty cycle = 50% $\pm 10\%$ | | dc | 16 | |

- NOTES: 1. The MSP430 CPU is clocked directly with MCLK.
Both the high and low phase of MCLK must not exceed the pulse width of the specified maximum frequency.
2. Modules might have a different maximum input clock specification. Refer to the specification of the respective module in this data sheet.

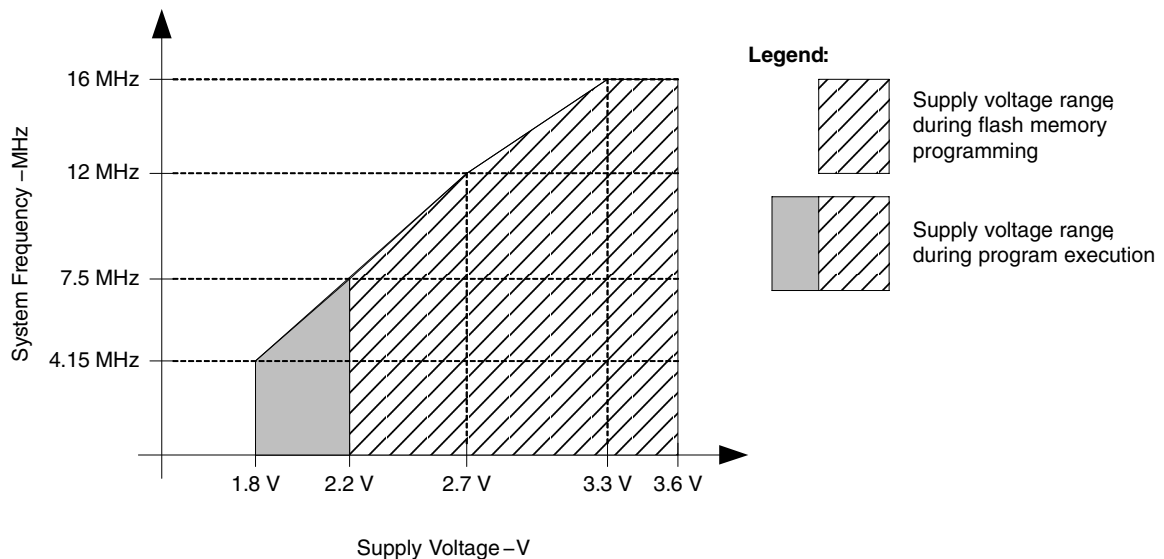

NOTE: Minimum processor frequency is defined by system clock. Flash program or erase operations require a minimum V_{CC} of 2.2 V.

Figure 1. Operating Area

MSP430x22x2, MSP430x22x4 MIXED SIGNAL MICROCONTROLLER

SLAS504B – JULY 2006 – REVISED JULY 2007

electrical characteristics over recommended ranges of supply voltage and operating free-air temperature (unless otherwise noted)

active mode supply current (into DV_{CC} + AV_{CC}) excluding external current (see Notes 1 and 2)

| PARAMETER | TEST CONDITIONS | T _A | V _{CC} | MIN | TYP | MAX | UNIT |
|--|--|----------------|-----------------|-----|-----|-----|------|
| I _{AM, 1MHz} Active mode (AM) current (1 MHz) | f _{DCO} = f _{MCLK} = f _{SMCLK} = 1 MHz, f _{ACLK} = 32,768 Hz, Program executes in flash, BCSCTL1 = CALBC1_1MHZ, DCOCTL = CALDCO_1MHZ, CPUOFF = 0, SCG0 = 0, SCG1 = 0, OSCOFF = 0 | | 2.2 V | | 270 | 390 | μA |
| | | | 3 V | | 390 | 550 | |
| I _{AM, 1MHz} Active mode (AM) current (1 MHz) | f _{DCO} = f _{MCLK} = f _{SMCLK} = 1 MHz, f _{ACLK} = 32,768 Hz, Program executes in RAM, BCSCTL1 = CALBC1_1MHZ, DCOCTL = CALDCO_1MHZ, CPUOFF = 0, SCG0 = 0, SCG1 = 0, OSCOFF = 0 | | 2.2 V | | 240 | | μA |
| | | | 3 V | | 340 | | |
| I _{AM, 4kHz} Active mode (AM) current (4 kHz) | f _{MCLK} = f _{SMCLK} = f _{ACLK} = 32,768 Hz/8 = 4,096 Hz, f _{DCO} = 0 Hz, Program executes in flash, SELMx = 11, SELS = 1, DIVMx = DIVSx = DIVAx = 11, CPUOFF = 0, SCG0 = 1, SCG1 = 0, OSCOFF = 0 | -40–85°C | 2.2 V | | 5 | 9 | μA |
| | | 105°C | 2.2 V | | | 18 | |
| | | -40–85°C | 3 V | | 6 | 10 | |
| | | 105°C | 3 V | | | 20 | |
| I _{AM, 100kHz} Active mode (AM) current (100 kHz) | f _{MCLK} = f _{SMCLK} = f _{DCO(0, 0)} ≈ 100 kHz, f _{ACLK} = 0 Hz, Program executes in flash, RSELx = 0, DCOx = 0, CPUOFF = 0, SCG0 = 0, SCG1 = 0, OSCOFF = 1 | -40–85°C | 2.2 V | | 60 | 85 | μA |
| | | 105°C | 2.2 V | | | 95 | |
| | | -40–85°C | 3 V | | 72 | 95 | |
| | | 105°C | 3 V | | | 105 | |

- NOTES: 1. All inputs are tied to 0 V or V_{CC}. Outputs do not source or sink any current.
2. The currents are characterized with a Micro Crystal CC4V-T1A SMD crystal with a load capacitance of 9 pF. The internal and external load capacitance is chosen to closely match the required 9 pF.



electrical characteristics over recommended ranges of supply voltage and operating free-air temperature (unless otherwise noted) (continued)

typical characteristics – active mode supply current (into $DV_{CC} + AV_{CC}$)

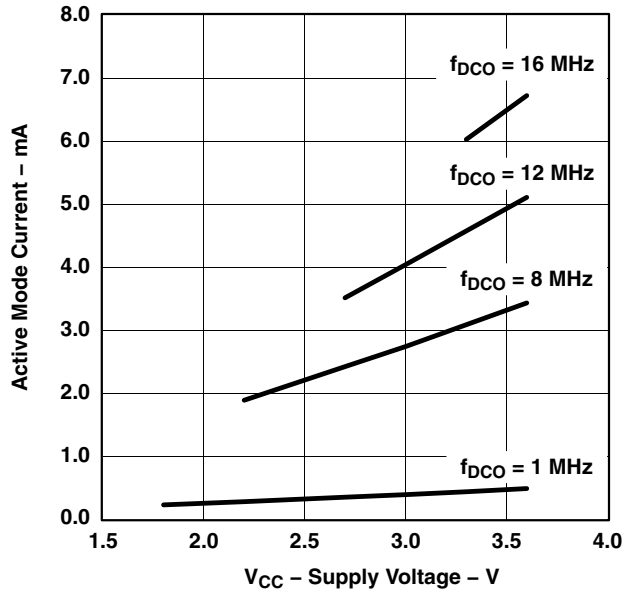

Figure 2. Active Mode Current vs V_{CC} , $T_A = 25^\circ\text{C}$

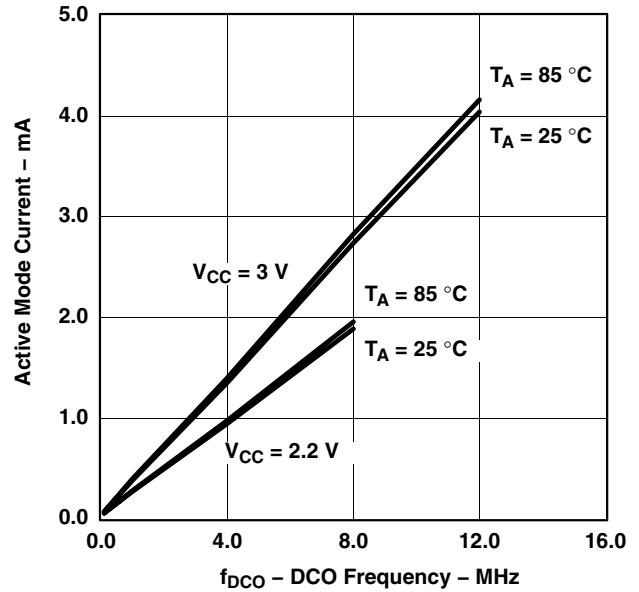

Figure 3. Active Mode Current vs DCO Frequency

MSP430x22x2, MSP430x22x4 MIXED SIGNAL MICROCONTROLLER

SLAS504B – JULY 2006 – REVISED JULY 2007

electrical characteristics over recommended ranges of supply voltage and operating free-air temperature (unless otherwise noted) (continued)

low power mode supply currents (into DV_{CC} + AV_{CC}) excluding external current (see Notes 1 and 2)

| PARAMETER | TEST CONDITIONS | T _A | V _{CC} | MIN | TYP | MAX | UNIT | |
|--|--|----------------|-----------------|-------|-----|-----|------|-----|
| I _{LPM0, 1MHz} Low-power mode 0 (LPM0) current, see Note 3 | f _{MCLK} = 0 MHz, f _{SMCLK} = f _{DCO} = 1 MHz, f _{ACLK} = 32,768 Hz, BCSCTL1 = CALBC1_1MHZ, DCOCTL = CALDCO_1MHZ, CPUOFF = 1, SCG0 = 0, SCG1 = 0, OSCOFF = 0 | | 2.2 V | | 75 | 90 | μA | |
| | | | 3 V | | 90 | 120 | | |
| I _{LPM0, 100kHz} Low-power mode 0 (LPM0) current, see Note 3 | f _{MCLK} = 0 MHz, f _{SMCLK} = f _{DCO(0, 0)} ≈ 100 kHz, f _{ACLK} = 0 Hz, RSELX = 0, DCOx = 0, CPUOFF = 1, SCG0 = 0, SCG1 = 0, OSCOFF = 1 | | 2.2 V | | 37 | 48 | μA | |
| | | | 3 V | | 41 | 65 | | |
| I _{LPM2} Low-power mode 2 (LPM2) current, see Note 4 | f _{MCLK} = f _{SMCLK} = 0 MHz, f _{DCO} = 1 MHz, f _{ACLK} = 32,768 Hz, BCSCTL1 = CALBC1_1MHZ, DCOCTL = CALDCO_1MHZ, CPUOFF = 1, SCG0 = 0, SCG1 = 1, OSCOFF = 0 | -40–85°C | 2.2 V | | 22 | 29 | μA | |
| | | | | 105°C | | | | 31 |
| | | 105°C | 3 V | | 25 | 32 | | |
| | | | | | | 34 | | |
| I _{LPM3, LFXT1} Low-power mode 3 (LPM3) current, see Note 4 | f _{DCO} = f _{MCLK} = f _{SMCLK} = 0 MHz, f _{ACLK} = 32,768 Hz, CPUOFF = 1, SCG0 = 1, SCG1 = 1, OSCOFF = 0 | -40°C | 2.2 V | | 0.7 | 1.4 | μA | |
| | | | | 25°C | | 0.7 | | 1.4 |
| | | | | 85°C | | 2.4 | | 3.3 |
| | | | | 105°C | | 5 | | 10 |
| | | 105°C | 3 V | | 0.9 | 1.5 | | |
| | | | | 25°C | | 0.9 | | 1.5 |
| | | | | 85°C | | 2.6 | | 3.8 |
| | | | | | | 6 | | 12 |
| I _{LPM3, VLO} Low-power mode 3 current, (LPM3) see Note 4 | f _{DCO} = f _{MCLK} = f _{SMCLK} = 0 MHz, f _{ACLK} from internal LF oscillator (VLO), CPUOFF = 1, SCG0 = 1, SCG1 = 1, OSCOFF = 0 | -40°C | 2.2 V | | 0.4 | 1.0 | μA | |
| | | | | 25°C | | 0.5 | | 1.0 |
| | | | | 85°C | | 1.8 | | 2.9 |
| | | | | 105°C | | 4.5 | | 9 |
| | | 105°C | 3 V | | 0.5 | 1.2 | | |
| | | | | 25°C | | 0.6 | | 1.2 |
| | | | | 85°C | | 2.1 | | 3.3 |
| | | | | | | 5.5 | | 11 |
| I _{LPM4} Low-power mode 4 (LPM4) current, see Note 5 | f _{DCO} = f _{MCLK} = f _{SMCLK} = 0 MHz, f _{ACLK} = 0 Hz, CPUOFF = 1, SCG0 = 1, SCG1 = 1, OSCOFF = 1 | -40°C | 2.2 V/3 V | | 0.1 | 0.5 | μA | |
| | | | | 25°C | | 0.1 | | 0.5 |
| | | | | 85°C | | 1.5 | | 3.0 |
| | | | | 105°C | | 4.5 | | 9 |

- NOTES: 1. All inputs are tied to 0 V or V_{CC}. Outputs do not source or sink any current.
 2. The currents are characterized with a Micro Crystal CC4V-T1A SMD crystal with a load capacitance of 9 pF. The internal and external load capacitance is chosen to closely match the required 9 pF.
 3. Current for brownout and WDT clocked by SMCLK included.
 4. Current for brownout and WDT clocked by ACLK included.
 5. Current for brownout included.



electrical characteristics over recommended ranges of supply voltage and operating free-air temperature (unless otherwise noted) (continued)

Schmitt-trigger inputs – Ports P1, P2, P3, P4, and RST/NMI

| PARAMETER | | TEST CONDITIONS | VCC | MIN | TYP | MAX | UNIT |
|-------------------|---|--|-------|------|-----|------|-----------------|
| V _{IT+} | Positive-going input threshold voltage | | | 0.45 | | 0.75 | V _{CC} |
| | | | 2.2 V | 1.00 | | 1.65 | V |
| | | | 3 V | 1.35 | | 2.25 | V |
| V _{IT-} | Negative-going input threshold voltage | | | 0.25 | | 0.55 | V _{CC} |
| | | | 2.2 V | 0.55 | | 1.20 | V |
| | | | 3 V | 0.75 | | 1.65 | V |
| V _{hys} | Input voltage hysteresis (V _{IT+} – V _{IT-}) | | 2.2 V | 0.2 | | 1.0 | V |
| | | | 3 V | 0.3 | | 1.0 | V |
| R _{Pull} | Pullup/pulldown resistor | For pullup: V _{IN} = V _{SS} ; For pulldown: V _{IN} = V _{CC} | | 20 | 35 | 50 | kΩ |
| C _I | Input capacitance | V _{IN} = V _{SS} or V _{CC} | | | 5 | | pF |

inputs – Ports P1 and P2

| PARAMETER | | TEST CONDITIONS | VCC | MIN | TYP | MAX | UNIT |
|--------------------|---------------------------|--|-----------|-----|-----|-----|------|
| t _(int) | External interrupt timing | Port P1, P2: P1.x to P2.x, External trigger pulse width to set interrupt flag (see Note 1) | 2.2 V/3 V | 20 | | | ns |

NOTES: 1. An external signal sets the interrupt flag every time the minimum interrupt pulse width t_(int) is met. It may be set even with trigger signals shorter than t_(int).

leakage current – Ports P1, P2, P3 and P4

| PARAMETER | | TEST CONDITIONS | VCC | MIN | TYP | MAX | UNIT |
|------------------------|--------------------------------|-------------------|-----------|-----|-----|-----|------|
| I _{lkg(Px.x)} | High-impedance leakage current | See Notes 1 and 2 | 2.2 V/3 V | | | ±50 | nA |

NOTES: 1. The leakage current is measured with V_{SS} or V_{CC} applied to the corresponding pin(s), unless otherwise noted.
2. The leakage of the digital port pins is measured individually. The port pin is selected for input and the pullup/pulldown resistor is disabled.



MSP430x22x2, MSP430x22x4 MIXED SIGNAL MICROCONTROLLER

SLAS504B – JULY 2006 – REVISED JULY 2007

electrical characteristics over recommended ranges of supply voltage and operating free-air temperature (unless otherwise noted) (continued)

outputs – Ports P1, P2, P3 and P4

| PARAMETER | TEST CONDITIONS | VCC | MIN | TYP | MAX | UNIT |
|--|---|-------|-----------------------|-----|-----------------------|------|
| V _{OH} High-level output voltage | I _(OHmax) = -1.5 mA (see Note 1) | 2.2 V | V _{CC} -0.25 | | V _{CC} | V |
| | I _(OHmax) = -6 mA (see Note 2) | 2.2 V | V _{CC} -0.6 | | V _{CC} | |
| | I _(OHmax) = -1.5 mA (see Note 1) | 3 V | V _{CC} -0.25 | | V _{CC} | |
| | I _(OHmax) = -6 mA (see Note 2) | 3 V | V _{CC} -0.6 | | V _{CC} | |
| V _{OL} Low-level output voltage | I _(OLmax) = 1.5 mA (see Note 1) | 2.2 V | V _{SS} | | V _{SS} +0.25 | V |
| | I _(OLmax) = 6 mA (see Note 2) | 2.2 V | V _{SS} | | V _{SS} +0.6 | |
| | I _(OLmax) = 1.5 mA (see Note 1) | 3 V | V _{SS} | | V _{SS} +0.25 | |
| | I _(OLmax) = 6 mA (see Note 2) | 3 V | V _{SS} | | V _{SS} +0.6 | |

- NOTES: 1. The maximum total current, I_{OHmax} and I_{OLmax}, for all outputs combined, should not exceed ±12 mA to hold the maximum voltage drop specified.
 2. The maximum total current, I_{OHmax} and I_{OLmax}, for all outputs combined, should not exceed ±48 mA to hold the maximum voltage drop specified.

output frequency – Ports P1, P2, P3 and P4

| PARAMETER | TEST CONDITIONS | VCC | MIN | TYP | MAX | UNIT |
|---|--|-------|-----|-----|-----|------|
| f _{Px.y} Port output frequency (with load) | P1.4/SMCLK, C _L = 20 pF, R _L = 1 kΩ against V _{CC} /2 (see Notes 1 and 2) | 2.2 V | | | 10 | MHz |
| | | 3 V | | | 12 | |
| f _{Port_CLK} Clock output frequency | P2.0/ACLK, P1.4/SMCLK, C _L = 20 pF (see Note 2) | 2.2 V | | | 12 | MHz |
| | | 3 V | | | 16 | |

- NOTES: 1. Alternatively a resistive divider with 2 times 2 kΩ between V_{CC} and V_{SS} is used as load. The output is connected to the center tap of the divider.
 2. The output voltage reaches at least 10% and 90% V_{CC} at the specified toggle frequency.

electrical characteristics over recommended ranges of supply voltage and operating free-air temperature (unless otherwise noted) (continued)

typical characteristics – outputs

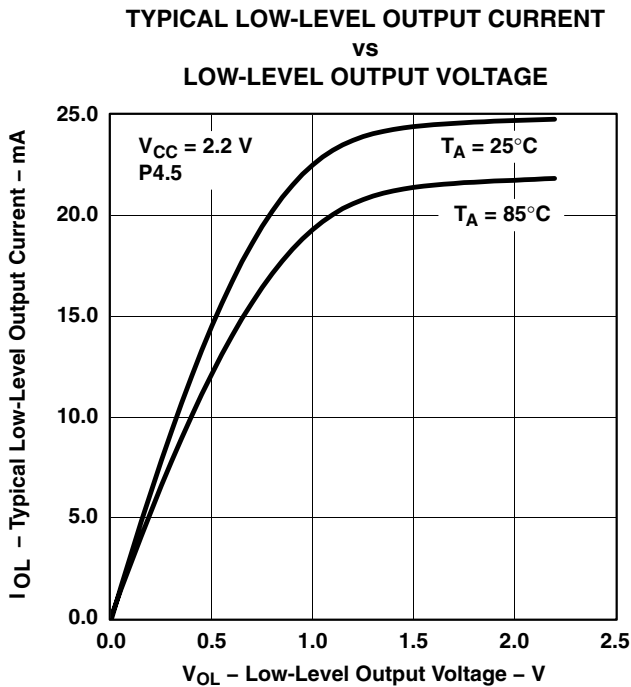

Figure 4

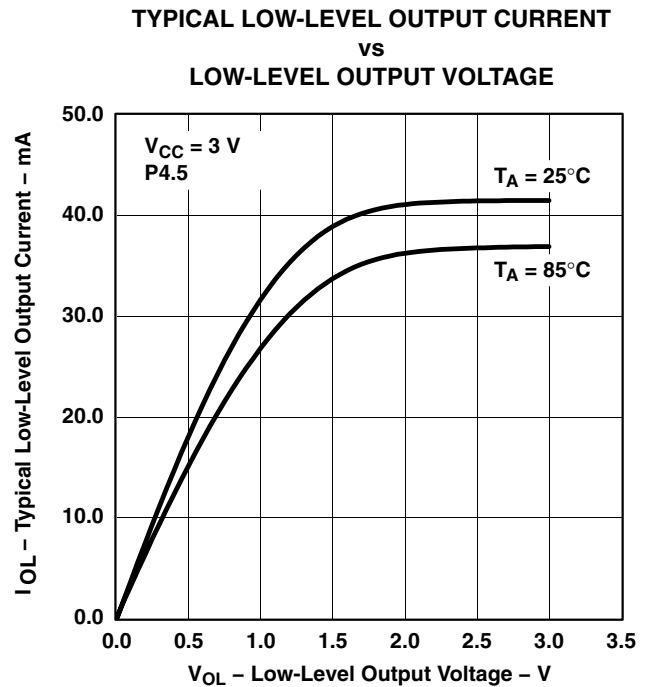

Figure 5

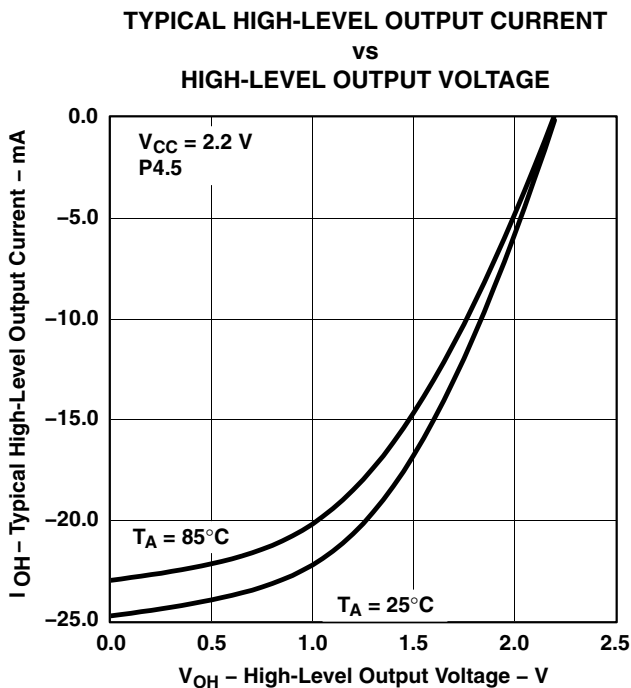

Figure 6

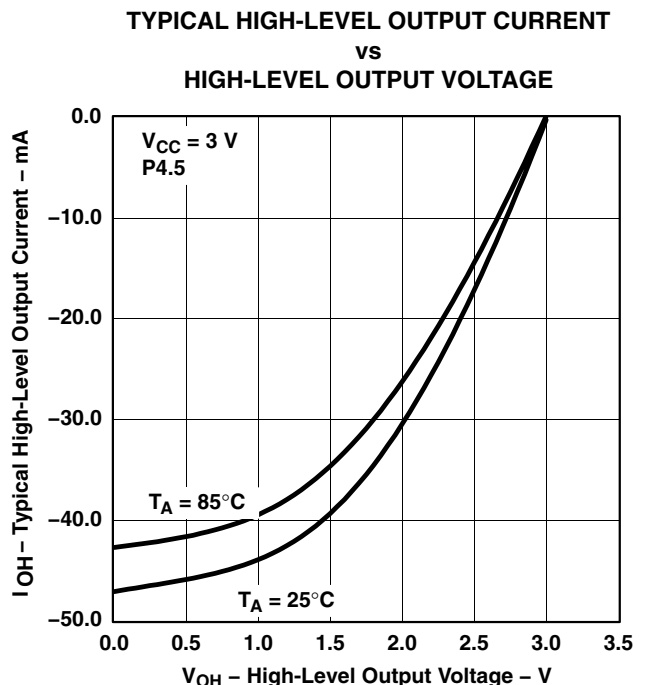

Figure 7

NOTE: One output loaded at a time

MSP430x22x2, MSP430x22x4 MIXED SIGNAL MICROCONTROLLER

SLAS504B – JULY 2006 – REVISED JULY 2007

electrical characteristics over recommended ranges of supply voltage and operating free-air temperature (unless otherwise noted) (continued)

POR/brownout reset (BOR) (see Notes 1 and 2)

| PARAMETER | TEST CONDITIONS | VCC | MIN | TYP | MAX | UNIT |
|-------------------|--|---------------------------------|-----|---------------------------|------|---------------|
| $V_{CC(start)}$ | See Figure 8 | $dV_{CC}/dt \leq 3 \text{ V/s}$ | | $0.7 \times V_{(B_IT-)}$ | | V |
| $V_{(B_IT-)}$ | See Figure 8 through Figure 10 | $dV_{CC}/dt \leq 3 \text{ V/s}$ | | | 1.71 | V |
| $V_{hys(B_IT-)}$ | See Figure 8 | $dV_{CC}/dt \leq 3 \text{ V/s}$ | 70 | 130 | 210 | mV |
| $t_d(BOR)$ | See Figure 8 | | | | 2000 | μs |
| $t_{(reset)}$ | Pulse length needed at $\overline{\text{RST}}/\text{NMI}$ pin to accepted reset internally | 2.2 V/3 V | 2 | | | μs |

- NOTES: 1. The current consumption of the brownout module is already included in the I_{CC} current consumption data. The voltage level $V_{(B_IT-)} + V_{hys(B_IT-)}$ is $\leq 1.8\text{V}$.
2. During power up, the CPU begins code execution following a period of $t_d(BOR)$ after $V_{CC} = V_{(B_IT-)} + V_{hys(B_IT-)}$. The default DCO settings must not be changed until $V_{CC} \geq V_{CC(min)}$, where $V_{CC(min)}$ is the minimum supply voltage for the desired operating frequency.

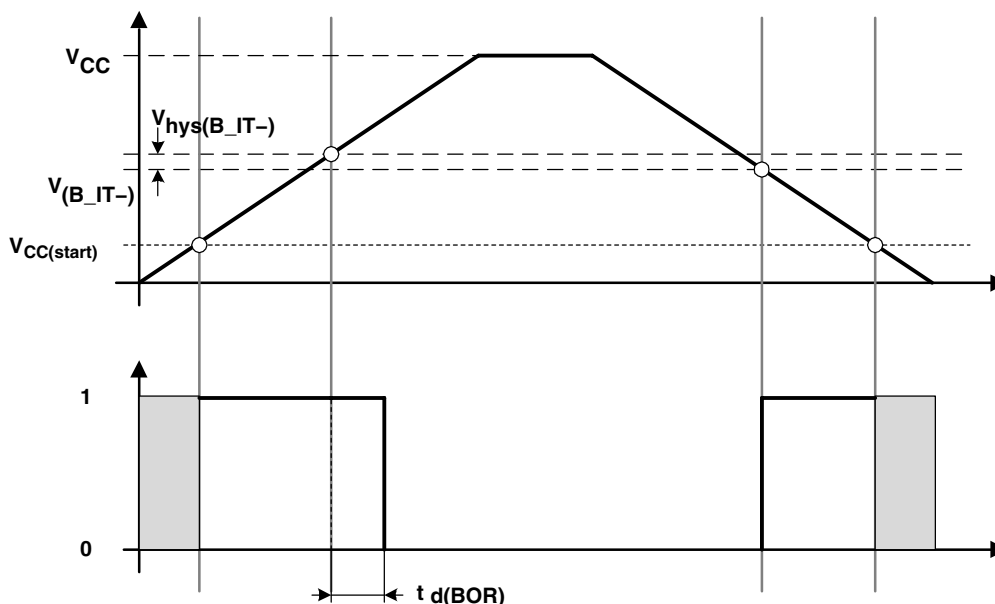

Figure 8. POR/Brownout Reset (BOR) vs Supply Voltage

electrical characteristics over recommended ranges of supply voltage and operating free-air temperature (unless otherwise noted) (continued)

typical characteristics – POR/brownout reset (BOR)

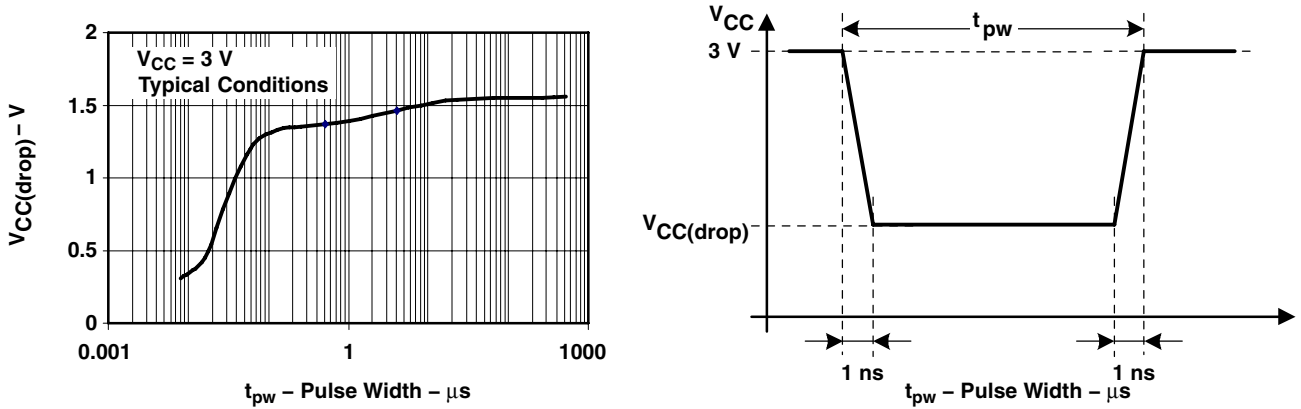

Figure 9. $V_{CC(drop)}$ Level With a Square Voltage Drop to Generate a POR/Brownout Signal

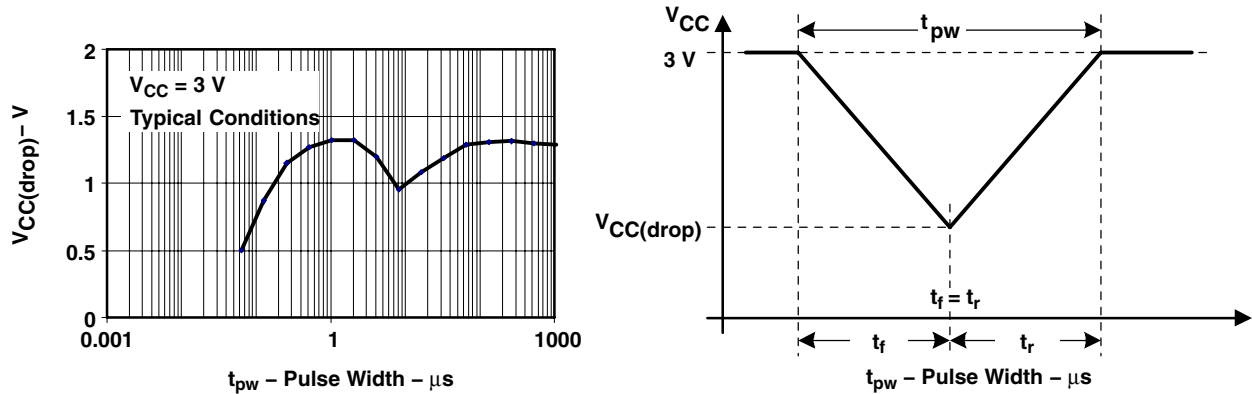

Figure 10. $V_{CC(drop)}$ Level With a Triangle Voltage Drop to Generate a POR/Brownout Signal

MSP430x22x2, MSP430x22x4 MIXED SIGNAL MICROCONTROLLER

SLAS504B – JULY 2006 – REVISED JULY 2007

electrical characteristics over recommended ranges of supply voltage and operating free-air temperature (unless otherwise noted) (continued)

main DCO characteristics

- All ranges selected by RSELx overlap with RSELx + 1: RSELx = 0 overlaps RSELx = 1, ... RSELx = 14 overlaps RSELx = 15.
- DCO control bits DCOx have a step size as defined by parameter S_{DCO}.
- Modulation control bits MODx select how often f_{DCO(RSEL,DCO+1)} is used within the period of 32 DCOCLK cycles. The frequency f_{DCO(RSEL,DCO)} is used for the remaining cycles. The frequency is an average equal to:

$$f_{average} = \frac{32 \times f_{DCO(RSEL,DCO)} \times f_{DCO(RSEL,DCO+1)}}{MOD \times f_{DCO(RSEL,DCO)} + (32 - MOD) \times f_{DCO(RSEL,DCO+1)}}$$

DCO frequency

| PARAMETER | TEST CONDITIONS | VCC | MIN | TYP | MAX | UNIT | |
|-----------------------------|--|--|-----------|------|------|-------|-------|
| Vcc Supply voltage range | RSELx < 14 | | 1.8 | | 3.6 | V | |
| | RSELx = 14 | | 2.2 | | 3.6 | | |
| | RSELx = 15 | | 3.0 | | 3.6 | | |
| f _{DCO(0,0)} | DCO frequency (0, 0) | RSELx = 0, DCOx = 0, MODx = 0 | 2.2 V/3 V | 0.06 | 0.14 | MHz | |
| f _{DCO(0,3)} | DCO frequency (0, 3) | RSELx = 0, DCOx = 3, MODx = 0 | 2.2 V/3 V | 0.07 | 0.17 | MHz | |
| f _{DCO(1,3)} | DCO frequency (1, 3) | RSELx = 1, DCOx = 3, MODx = 0 | 2.2 V/3 V | 0.10 | 0.20 | MHz | |
| f _{DCO(2,3)} | DCO frequency (2, 3) | RSELx = 2, DCOx = 3, MODx = 0 | 2.2 V/3 V | 0.14 | 0.28 | MHz | |
| f _{DCO(3,3)} | DCO frequency (3, 3) | RSELx = 3, DCOx = 3, MODx = 0 | 2.2 V/3 V | 0.20 | 0.40 | MHz | |
| f _{DCO(4,3)} | DCO frequency (4, 3) | RSELx = 4, DCOx = 3, MODx = 0 | 2.2 V/3 V | 0.28 | 0.54 | MHz | |
| f _{DCO(5,3)} | DCO frequency (5, 3) | RSELx = 5, DCOx = 3, MODx = 0 | 2.2 V/3 V | 0.39 | 0.77 | MHz | |
| f _{DCO(6,3)} | DCO frequency (6, 3) | RSELx = 6, DCOx = 3, MODx = 0 | 2.2 V/3 V | 0.54 | 1.06 | MHz | |
| f _{DCO(7,3)} | DCO frequency (7, 3) | RSELx = 7, DCOx = 3, MODx = 0 | 2.2 V/3 V | 0.80 | 1.50 | MHz | |
| f _{DCO(8,3)} | DCO frequency (8, 3) | RSELx = 8, DCOx = 3, MODx = 0 | 2.2 V/3 V | 1.10 | 2.10 | MHz | |
| f _{DCO(9,3)} | DCO frequency (9, 3) | RSELx = 9, DCOx = 3, MODx = 0 | 2.2 V/3 V | 1.60 | 3.00 | MHz | |
| f _{DCO(10,3)} | DCO frequency (10, 3) | RSELx = 10, DCOx = 3, MODx = 0 | 2.2 V/3 V | 2.50 | 4.30 | MHz | |
| f _{DCO(11,3)} | DCO frequency (11, 3) | RSELx = 11, DCOx = 3, MODx = 0 | 2.2 V/3 V | 3.00 | 5.50 | MHz | |
| f _{DCO(12,3)} | DCO frequency (12, 3) | RSELx = 12, DCOx = 3, MODx = 0 | 2.2 V/3 V | 4.30 | 7.30 | MHz | |
| f _{DCO(13,3)} | DCO frequency (13, 3) | RSELx = 13, DCOx = 3, MODx = 0 | 2.2 V/3 V | 6.00 | 9.60 | MHz | |
| f _{DCO(14,3)} | DCO frequency (14, 3) | RSELx = 14, DCOx = 3, MODx = 0 | 2.2 V/3 V | 8.60 | 13.9 | MHz | |
| f _{DCO(15,3)} | DCO frequency (15, 3) | RSELx = 15, DCOx = 3, MODx = 0 | 3 V | 12.0 | 18.5 | MHz | |
| f _{DCO(15,7)} | DCO frequency (15, 7) | RSELx = 15, DCOx = 7, MODx = 0 | 3 V | 16.0 | 26.0 | MHz | |
| S _{RSEL} | Frequency step between range RSEL and RSEL+1 | S _{RSEL} = f _{DCO(RSEL+1,DCO)} /f _{DCO(RSEL,DCO)} | 2.2 V/3 V | | 1.55 | ratio | |
| S _{DCO} | Frequency step between tap DCO and DCO+1 | S _{DCO} = f _{DCO(RSEL,DCO+1)} /f _{DCO(RSEL,DCO)} | 2.2 V/3 V | 1.05 | 1.08 | 1.12 | ratio |
| Duty Cycle | Measured at P1.4/SMCLK | 2.2 V/3 V | 40 | 50 | 60 | % | |



electrical characteristics over recommended ranges of supply voltage and operating free-air temperature (unless otherwise noted) (continued)

calibrated DCO frequencies – tolerance at calibration

| PARAMETER | | TEST CONDITIONS | T _A | VCC | MIN | TYP | MAX | UNIT |
|------------------------------------|--------------------------|---|----------------|-----|-------|------|-------|------|
| Frequency tolerance at calibration | | | 25°C | 3 V | -1 | ±0.2 | +1 | % |
| f _{CAL(1MHz)} | 1-MHz calibration value | BCSCTL1= CALBC1_1MHZ, DCOCTL = CALDCO_1MHZ, Gating time: 5 ms | 25°C | 3 V | 0.990 | 1 | 1.010 | MHz |
| f _{CAL(8MHz)} | 8-MHz calibration value | BCSCTL1= CALBC1_8MHZ, DCOCTL = CALDCO_8MHZ, Gating time: 5 ms | 25°C | 3 V | 7.920 | 8 | 8.080 | MHz |
| f _{CAL(12MHz)} | 12-MHz calibration value | BCSCTL1= CALBC1_12MHZ, DCOCTL = CALDCO_12MHZ, Gating time: 5 ms | 25°C | 3 V | 11.88 | 12 | 12.12 | MHz |
| f _{CAL(16MHz)} | 16-MHz calibration value | BCSCTL1= CALBC1_16MHZ, DCOCTL = CALDCO_16MHZ, Gating time: 2 ms | 25°C | 3 V | 15.84 | 16 | 16.16 | MHz |

calibrated DCO frequencies – tolerance over temperature 0°C to +85°C

| PARAMETER | | TEST CONDITIONS | T _A | VCC | MIN | TYP | MAX | UNIT |
|-----------------------------------|--------------------------|---|----------------|-------|-------|------|-------|------|
| 1-MHz tolerance over temperature | | | 0–85°C | 3.0 V | -2.5 | ±0.5 | +2.5 | % |
| 8-MHz tolerance over temperature | | | 0–85°C | 3.0 V | -2.5 | ±1.0 | +2.5 | % |
| 12-MHz tolerance over temperature | | | 0–85°C | 3.0 V | -2.5 | ±1.0 | +2.5 | % |
| 16-MHz tolerance over temperature | | | 0–85°C | 3.0 V | -3.0 | ±2.0 | +3.0 | % |
| f _{CAL(1MHz)} | 1-MHz calibration value | BCSCTL1= CALBC1_1MHZ, DCOCTL = CALDCO_1MHZ, Gating time: 5 ms | 0–85°C | 2.2 V | 0.970 | 1 | 1.030 | MHz |
| | | | | 3.0 V | 0.975 | 1 | 1.025 | |
| | | | | 3.6 V | 0.970 | 1 | 1.030 | |
| f _{CAL(8MHz)} | 8-MHz calibration value | BCSCTL1= CALBC1_8MHZ, DCOCTL = CALDCO_8MHZ, Gating time: 5 ms | 0–85°C | 2.2 V | 7.760 | 8 | 8.400 | MHz |
| | | | | 3.0 V | 7.800 | 8 | 8.200 | |
| | | | | 3.6 V | 7.600 | 8 | 8.240 | |
| f _{CAL(12MHz)} | 12-MHz calibration value | BCSCTL1= CALBC1_12MHZ, DCOCTL = CALDCO_12MHZ, Gating time: 5 ms | 0–85°C | 2.2 V | 11.70 | 12 | 12.30 | MHz |
| | | | | 3.0 V | 11.70 | 12 | 12.30 | |
| | | | | 3.6 V | 11.70 | 12 | 12.30 | |
| f _{CAL(16MHz)} | 16-MHz calibration value | BCSCTL1= CALBC1_16MHZ, DCOCTL = CALDCO_16MHZ, Gating time: 2 ms | 0–85°C | 3.0 V | 15.52 | 16 | 16.48 | MHz |
| | | | | 3.6 V | 15.00 | 16 | 16.48 | |



MSP430x22x2, MSP430x22x4 MIXED SIGNAL MICROCONTROLLER

SLAS504B – JULY 2006 – REVISED JULY 2007

electrical characteristics over recommended ranges of supply voltage and operating free-air temperature (unless otherwise noted) (continued)

calibrated DCO frequencies – tolerance over supply voltage V_{CC}

| PARAMETER | TEST CONDITIONS | T_A | VCC | MIN | TYP | MAX | UNIT |
|---|---|-------|---------------|-------|-----|-------|------|
| 1-MHz tolerance over V_{CC} | | 25°C | 1.8 V – 3.6 V | -3 | ±2 | +3 | % |
| 8-MHz tolerance over V_{CC} | | 25°C | 1.8 V – 3.6 V | -3 | ±2 | +3 | % |
| 12-MHz tolerance over V_{CC} | | 25°C | 2.2 V – 3.6 V | -3 | ±2 | +3 | % |
| 16 -Hz tolerance over V_{CC} | | 25°C | 3.0 V – 3.6 V | -6 | ±2 | +3 | % |
| $f_{CAL(1MHz)}$ 1-MHz calibration value | BCSCTL1= CALBC1_1MHZ, DCOCTL = CALDCO_1MHZ, Gating time: 5 ms | 25°C | 1.8 V – 3.6 V | 0.970 | 1 | 1.030 | MHz |
| $f_{CAL(8MHz)}$ 8-MHz calibration value | BCSCTL1= CALBC1_8MHZ, DCOCTL = CALDCO_8MHZ, Gating time: 5 ms | 25°C | 1.8 V – 3.6 V | 7.760 | 8 | 8.240 | MHz |
| $f_{CAL(12MHz)}$ 12-MHz calibration value | BCSCTL1= CALBC1_12MHZ, DCOCTL = CALDCO_12MHZ, Gating time: 5 ms | 25°C | 2.2 V – 3.6 V | 11.64 | 12 | 12.36 | MHz |
| $f_{CAL(16MHz)}$ 16-MHz calibration value | BCSCTL1= CALBC1_16MHZ, DCOCTL = CALDCO_16MHZ, Gating time: 2 ms | 25°C | 3.0 V – 3.6 V | 15.00 | 16 | 16.48 | MHz |

calibrated DCO frequencies – overall tolerance

| PARAMETER | TEST CONDITIONS | T_A | VCC | MIN | TYP | MAX | UNIT |
|---|---|-----------------------------|----------------|-------|-----|-------|------|
| 1-MHz tolerance overall | | I: -40–85°C T: -40–105°C | 1.8 V to 3.6 V | -5 | ±2 | +5 | % |
| 8-MHz tolerance overall | | I: -40–85°C T: -40–105°C | 1.8 V to 3.6 V | -5 | ±2 | +5 | % |
| 12-MHz tolerance overall | | I: -40–85°C T: -40–105°C | 2.2 V to 3.6 V | -5 | ±2 | +5 | % |
| 16-MHz tolerance overall | | I: -40–85°C T: -40–105°C | 3.0 V to 3.6 V | -6 | ±3 | +6 | % |
| $f_{CAL(1MHz)}$ 1-MHz calibration value | BCSCTL1= CALBC1_1MHZ, DCOCTL = CALDCO_1MHZ, Gating time: 5 ms | I: -40–85°C T: -40–105°C | 1.8 V to 3.6 V | 0.950 | 1 | 1.050 | MHz |
| $f_{CAL(8MHz)}$ 8-MHz calibration value | BCSCTL1= CALBC1_8MHZ, DCOCTL = CALDCO_8MHZ, Gating time: 5 ms | I: -40–85°C T: -40–105°C | 1.8 V to 3.6 V | 7.600 | 8 | 8.400 | MHz |
| $f_{CAL(12MHz)}$ 12-MHz calibration value | BCSCTL1= CALBC1_12MHZ, DCOCTL = CALDCO_12MHZ, Gating time: 5 ms | I: -40–85°C T: -40–105°C | 2.2 V to 3.6 V | 11.40 | 12 | 12.60 | MHz |
| $f_{CAL(16MHz)}$ 16-MHz calibration value | BCSCTL1= CALBC1_16MHZ, DCOCTL = CALDCO_16MHZ, Gating time: 2 ms | I: -40–85°C T: -40–105°C | 3.0 V to 3.6 V | 15.00 | 16 | 17.00 | MHz |

typical characteristics – calibrated 1-MHz DCO frequency

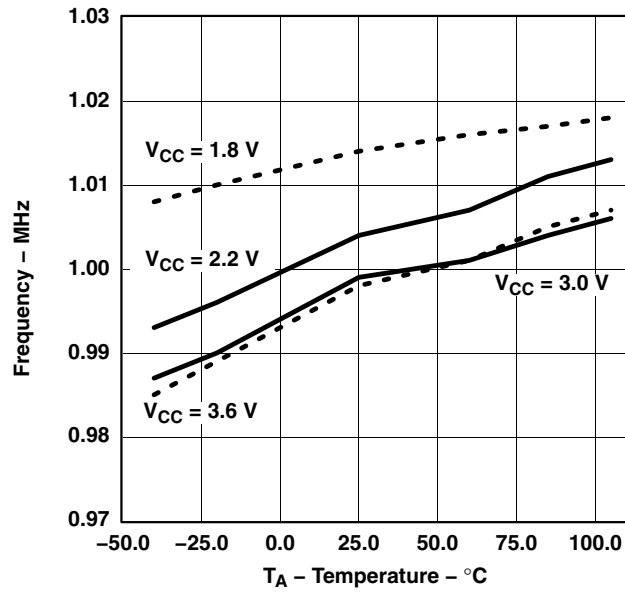

Figure 11. Calibrated 1-MHz Frequency vs Temperature

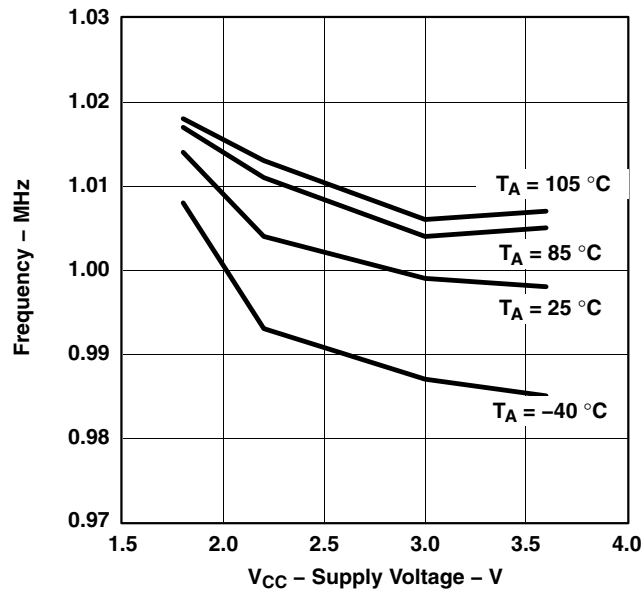

Figure 12. Calibrated 1-MHz Frequency vs V_{CC}

MSP430x22x2, MSP430x22x4 MIXED SIGNAL MICROCONTROLLER

SLAS504B – JULY 2006 – REVISED JULY 2007

electrical characteristics over recommended ranges of supply voltage and operating free-air temperature (unless otherwise noted) (continued)

wake-up from lower power modes (LPM3/4)

| PARAMETER | TEST CONDITIONS | VCC | MIN | TYP | MAX | UNIT |
|--|---|-----------|-----|--------------------------------------|-----|---------|
| $t_{DCO,LPM3/4}$ DCO clock wake-up time from LPM3/4 (see Note 1) | BCSCTL1= CALBC1_1MHZ, DCOCTL = CALDCO_1MHZ | 2.2 V/3 V | | | 2 | μ s |
| | BCSCTL1= CALBC1_8MHZ, DCOCTL = CALDCO_8MHZ | 2.2 V/3 V | | | 1.5 | |
| | BCSCTL1= CALBC1_12MHZ, DCOCTL = CALDCO_12MHZ | 2.2 V/3 V | | | 1 | |
| | BCSCTL1= CALBC1_16MHZ, DCOCTL = CALDCO_16MHZ | 3 V | | | 1 | |
| $t_{CPU,LPM3/4}$ CPU wake-up time from LPM3/4 (see Note 2) | | | | $1/f_{MCLK} +$ $t_{Clock,LPM3/4}$ | | |

NOTES: 1. The DCO clock wake-up time is measured from the edge of an external wake-up signal (e.g., port interrupt) to the first clock edge observable externally on a clock pin (MCLK or SMCLK).
2. Parameter applicable only if DCOCLK is used for MCLK.

typical characteristics – DCO clock wake-up time from LPM3/4

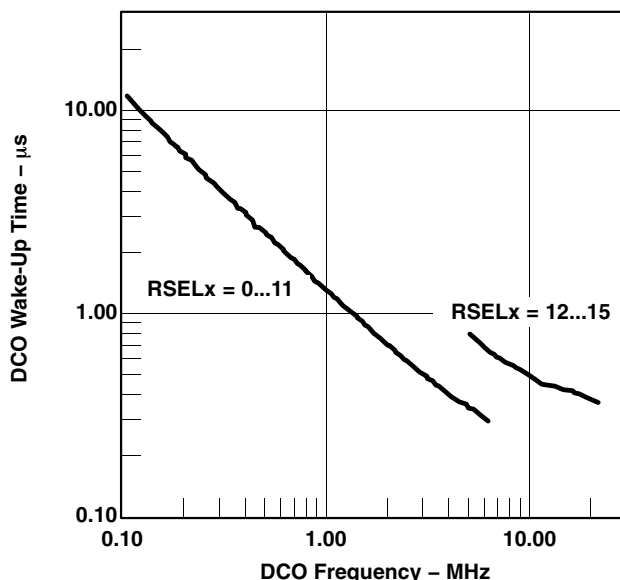

Figure 13. Clock Wake-Up Time From LPM3 vs DCO Frequency

electrical characteristics over recommended ranges of supply voltage and operating free-air temperature (unless otherwise noted) (continued)

DCO with external resistor R_{OSC} (see Note 1)

| PARAMETER | TEST CONDITIONS | VCC | MIN | TYP | MAX | UNIT |
|--|---|-----------|-----|-----------|-----|---------------------|
| $f_{DCO,ROSC}$ DCO output frequency with R_{OSC} | DCOR = 1, RSELx = 4, DCOx = 3, MODx = 0, $T_A = 25^\circ\text{C}$ | 2.2 V | | 1.8 | | MHz |
| | | 3 V | | 1.95 | | |
| D_t Temperature drift | DCOR = 1, RSELx = 4, DCOx = 3, MODx = 0 | 2.2 V/3 V | | ± 0.1 | | %/ $^\circ\text{C}$ |
| D_V Drift with V_{CC} | DCOR = 1, RSELx = 4, DCOx = 3, MODx = 0 | 2.2 V/3 V | | 10 | | %/V |

NOTES: 1. $R_{OSC} = 100\text{k}\Omega$. Metal film resistor, type 0257. 0.6 watt with 1% tolerance and $T_K = \pm 50\text{ppm}/^\circ\text{C}$.

typical characteristics – DCO with external resistor R_{OSC}

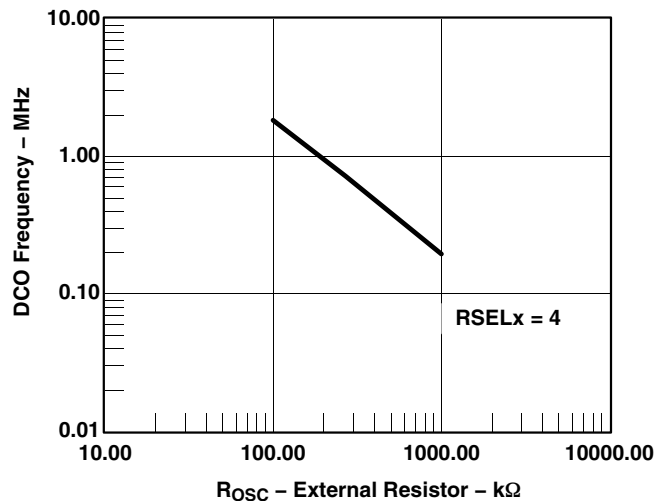

Figure 14. DCO Frequency vs R_{OSC} , $V_{CC} = 2.2\text{ V}$, $T_A = 25^\circ\text{C}$

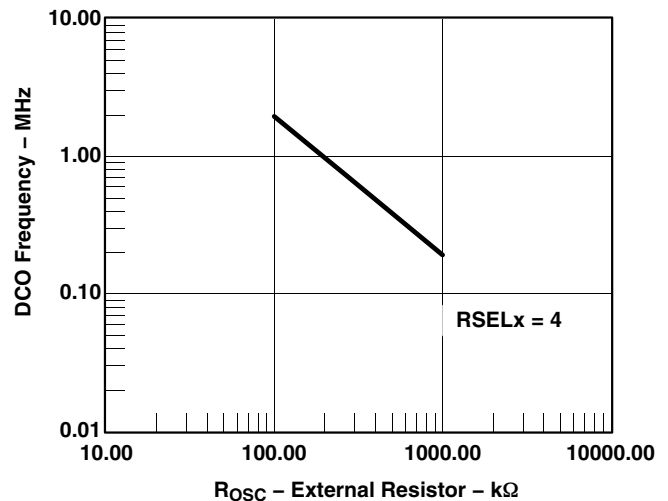

Figure 15. DCO Frequency vs R_{OSC} , $V_{CC} = 3.0\text{ V}$, $T_A = 25^\circ\text{C}$

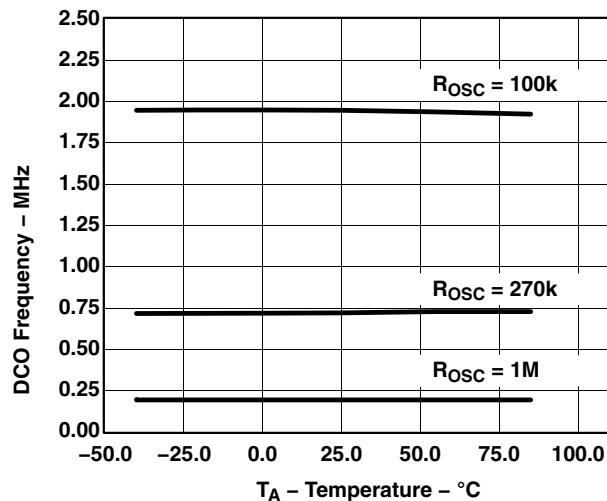

Figure 16. DCO Frequency vs Temperature, $V_{CC} = 3.0\text{ V}$

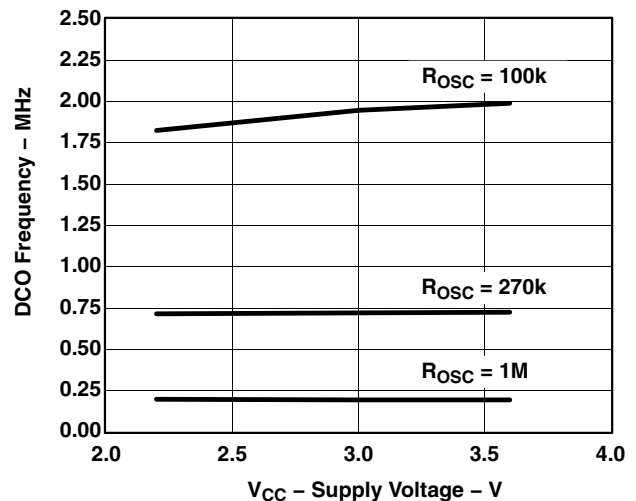

Figure 17. DCO Frequency vs V_{CC} , $T_A = 25^\circ\text{C}$

MSP430x22x2, MSP430x22x4 MIXED SIGNAL MICROCONTROLLER

SLAS504B – JULY 2006 – REVISED JULY 2007

electrical characteristics over recommended ranges of supply voltage and operating free-air temperature (unless otherwise noted) (continued)

crystal oscillator, LFXT1, low frequency modes (see Note 4)

| PARAMETER | | TEST CONDITIONS | VCC | MIN | TYP | MAX | UNIT |
|----------------------|---|--|---------------|--------|--------|--------|------------|
| $f_{LFXT1,LF}$ | LFXT1 oscillator crystal frequency, LF mode 0, 1 | XTS = 0, LFXT1Sx = 0 or 1 | 1.8 V – 3.6 V | | 32,768 | | Hz |
| $f_{LFXT1,LF,logic}$ | LFXT1 oscillator logic level square wave input frequency, LF mode | XTS = 0, LFXT1Sx = 3 | 1.8 V – 3.6 V | 10,000 | 32,768 | 50,000 | Hz |
| OA_{LF} | Oscillation allowance for LF crystals | XTS = 0, LFXT1Sx = 0; $f_{LFXT1,LF} = 32,768$ kHz, $C_{L,eff} = 6$ pF | | | 500 | | k Ω |
| | | XTS = 0, LFXT1Sx = 0; $f_{LFXT1,LF} = 32,768$ kHz, $C_{L,eff} = 12$ pF | | | 200 | | |
| $C_{L,eff}$ | Integrated effective load capacitance, LF mode (see Note 1) | XTS = 0, XCAPx = 0 | | | 1 | | pF |
| | | XTS = 0, XCAPx = 1 | | | 5.5 | | |
| | | XTS = 0, XCAPx = 2 | | | 8.5 | | |
| | | XTS = 0, XCAPx = 3 | | | 11 | | |
| Duty Cycle | LF mode | XTS = 0, Measured at P1.4/ACLK, $f_{LFXT1,LF} = 32,768$ Hz | 2.2 V/3 V | 30 | 50 | 70 | % |
| $f_{Fault,LF}$ | Oscillator fault frequency, LF mode (see Note 3) | XTS = 0, LFXT1Sx = 3 (see Note 2) | 2.2 V/3 V | 10 | | 10,000 | Hz |

- NOTES: 1. Includes parasitic bond and package capacitance (approximately 2pF per pin).
Since the PCB adds additional capacitance it is recommended to verify the correct load by measuring the ACLK frequency. For a correct setup the effective load capacitance should always match the specification of the used crystal.
2. Measured with logic level input frequency but also applies to operation with crystals.
3. Frequencies below the MIN specification set the fault flag, frequencies above the MAX specification do not set the fault flag. Frequencies in between might set the flag.
4. To improve EMI on the LFXT1 oscillator the following guidelines should be observed.
- Keep as short a trace as possible between the device and the crystal.
 - Design a good ground plane around the oscillator pins.
 - Prevent crosstalk from other clock or data lines into oscillator pins XIN and XOUT.
 - Avoid running PCB traces underneath or adjacent to the XIN and XOUT pins.
 - Use assembly materials and praxis to avoid any parasitic load on the oscillator XIN and XOUT pins.
 - If conformal coating is used, ensure that it does not induce capacitive/resistive leakage between the oscillator pins.
 - Do not route the XOUT line to the JTAG header to support the serial programming adapter as shown in other documentation. This signal is no longer required for the serial programming adapter.

internal very low power, low frequency oscillator (VLO)

| PARAMETER | TEST CONDITIONS | T_A | VCC | MIN | TYP | MAX | UNIT |
|--------------------|---|-----------------------------|-------------|-----|-----|-----|------|
| f_{VLO} | VLO frequency | -40–85°C | 2.2 V/3 V | 4 | 12 | 20 | kHz |
| | | 105°C | 2.2 V/3 V | | | 22 | |
| df_{VLO}/dT | VLO frequency temperature drift (see Note 1) | I: -40–85°C T: -40–105°C | 2.2 V/3 V | | 0.5 | | %/°C |
| df_{VLO}/dV_{CC} | VLO frequency supply voltage drift (see Note 2) | 25°C | 1.8V – 3.6V | | 4 | | %/V |

- NOTES: 1. Calculated using the box method:
I version: $(MAX(-40...85^\circ C) - MIN(-40...85^\circ C)) / (MIN(-40...85^\circ C) / (85^\circ C - (-40^\circ C)))$
T version: $(MAX(-40...105^\circ C) - MIN(-40...105^\circ C)) / (MIN(-40...105^\circ C) / (105^\circ C - (-40^\circ C)))$
2. Calculated using the box method: $(MAX(1.8...3.6 V) - MIN(1.8...3.6 V)) / (MIN(1.8...3.6 V) / (3.6 V - 1.8 V))$



electrical characteristics over recommended ranges of supply voltage and operating free-air temperature (unless otherwise noted) (continued)

crystal oscillator, LFXT1, high frequency modes (see Note 5)

| PARAMETER | | TEST CONDITIONS | VCC | MIN | TYP | MAX | UNIT |
|----------------------|---|--|---------------|------|-----|-----|----------|
| $f_{LFXT1,HF0}$ | LFXT1 oscillator crystal frequency, HF mode 0 | XTS = 1, LFXT1Sx = 0 | 1.8 V – 3.6 V | 0.4 | | 1 | MHz |
| $f_{LFXT1,HF1}$ | LFXT1 oscillator crystal frequency, HF mode 1 | XTS = 1, LFXT1Sx = 1 | 1.8 V – 3.6 V | 1 | | 4 | MHz |
| $f_{LFXT1,HF2}$ | LFXT1 oscillator crystal frequency, HF mode 2 | XTS = 1, LFXT1Sx = 2 | 1.8 V – 3.6 V | 2 | | 10 | MHz |
| | | | 2.2 V – 3.6 V | 2 | | 12 | |
| | | | 3.0 V – 3.6 V | 2 | | 16 | |
| $f_{LFXT1,HF,logic}$ | LFXT1 oscillator logic level square-wave input frequency, HF mode | XTS = 1, LFXT1Sx = 3 | 1.8 V – 3.6 V | 0.4 | | 10 | MHz |
| | | | 2.2 V – 3.6 V | 0.4 | | 12 | |
| | | | 3.0 V – 3.6 V | 0.4 | | 16 | |
| OA _{HF} | Oscillation allowance for HF crystals (see Figure 18 and Figure 19) | XTS = 0, LFXT1Sx = 0, $f_{LFXT1,HF} = 1$ MHz, $C_{L,eff} = 15$ pF | | 2700 | | | Ω |
| | | XTS = 0, LFXT1Sx = 1 $f_{LFXT1,HF} = 4$ MHz, $C_{L,eff} = 15$ pF | | 800 | | | |
| | | XTS = 0, LFXT1Sx = 2 $f_{LFXT1,HF} = 16$ MHz, $C_{L,eff} = 15$ pF | | 300 | | | |
| $C_{L,eff}$ | Integrated effective load capacitance, HF mode (see Note 1) | XTS = 1 (see Note 2) | | 1 | | | pF |
| Duty Cycle | HF mode | XTS = 1, Measured at P1.4/ACLK, $f_{LFXT1,HF} = 10$ MHz | 2.2 V/3 V | 40 | 50 | 60 | % |
| | | XTS = 1, Measured at P1.4/ACLK, $f_{LFXT1,HF} = 16$ MHz | 2.2 V/3 V | 40 | 50 | 60 | |
| $f_{Fault,HF}$ | Oscillator fault frequency, HF mode (see Note 4) | XTS = 1, LFXT1Sx = 3 (see Notes 3) | 2.2 V/3 V | 30 | | 300 | kHz |

- NOTES: 1. Includes parasitic bond and package capacitance (approximately 2 pF per pin).
 Since the PCB adds additional capacitance it is recommended to verify the correct load by measuring the ACLK frequency. For a correct setup the effective load capacitance should always match the specification of the used crystal.
2. Requires external capacitors at both terminals. Values are specified by crystal manufacturers.
3. Measured with logic level input frequency but also applies to operation with crystals.
4. Frequencies below the MIN specification set the fault flag, frequencies above the MAX specification do not set the fault flag. Frequencies in between might set the flag.
5. To improve EMI on the LFXT1 oscillator the following guidelines should be observed.
- Keep as short a trace as possible between the device and the crystal.
 - Design a good ground plane around the oscillator pins.
 - Prevent crosstalk from other clock or data lines into oscillator pins XIN and XOUT.
 - Avoid running PCB traces underneath or adjacent to the XIN and XOUT pins.
 - Use assembly materials and praxis to avoid any parasitic load on the oscillator XIN and XOUT pins.
 - If conformal coating is used, ensure that it does not induce capacitive/resistive leakage between the oscillator pins.
 - Do not route the XOUT line to the JTAG header to support the serial programming adapter as shown in other documentation. This signal is no longer required for the serial programming adapter.

MSP430x22x2, MSP430x22x4 MIXED SIGNAL MICROCONTROLLER

SLAS504B – JULY 2006 – REVISED JULY 2007

electrical characteristics over recommended ranges of supply voltage and operating free-air temperature (unless otherwise noted) (continued)

typical characteristics – LFXT1 oscillator in HF mode (XTS = 1)

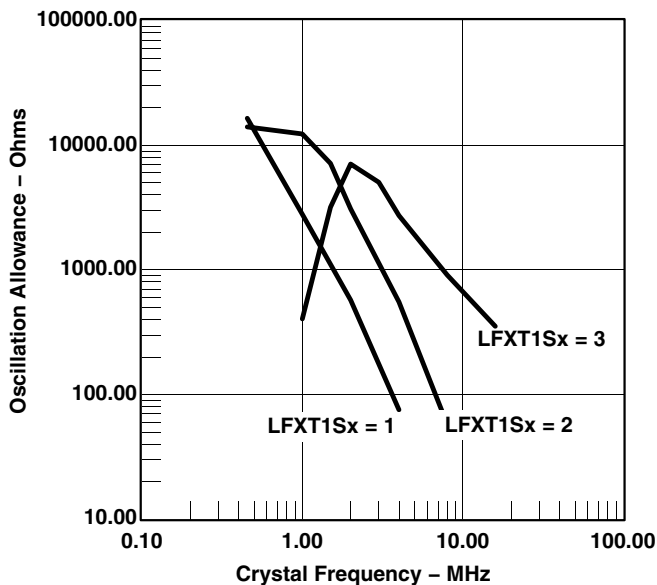

Figure 18. Oscillation Allowance vs Crystal Frequency, $C_{L,eff} = 15 \text{ pF}$, $T_A = 25^\circ\text{C}$

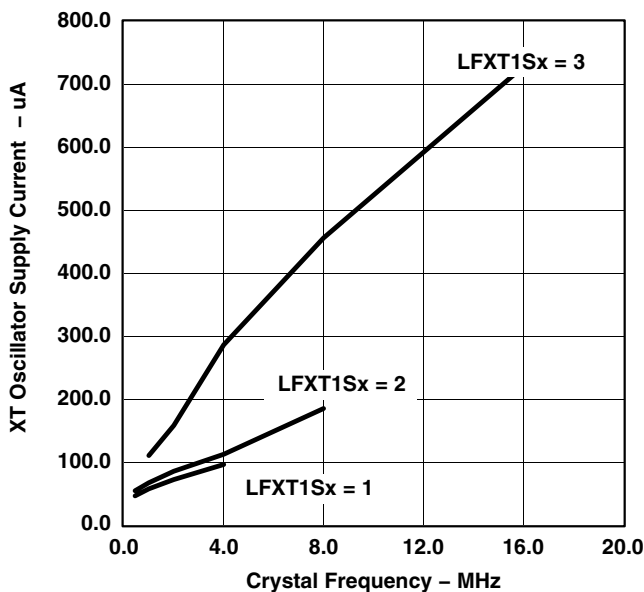

Figure 19. XT Oscillator Supply Current vs Crystal Frequency, $C_{L,eff} = 15 \text{ pF}$, $T_A = 25^\circ\text{C}$

electrical characteristics over recommended ranges of supply voltage and operating free-air temperature (unless otherwise noted) (continued)

Timer_A

| PARAMETER | | TEST CONDITIONS | VCC | MIN | TYP | MAX | UNIT |
|---------------------|-------------------------|--|-----------|-----|-----|-----|------|
| f _{TA} | Timer_A clock frequency | Internal: SMCLK, ACLK, External: TACLK, INCLK, Duty cycle = 50% ±10% | 2.2 V | | | 10 | MHz |
| | | | 3 V | | | 16 | |
| t _{TA,cap} | Timer_A, capture timing | TA0, TA1, TA2 | 2.2 V/3 V | 20 | | | ns |

Timer_B

| PARAMETER | | TEST CONDITIONS | VCC | MIN | TYP | MAX | UNIT |
|---------------------|-------------------------|---|-----------|-----|-----|-----|------|
| f _{TB} | Timer_B clock frequency | Internal: SMCLK, ACLK, External: TBCLK, Duty cycle = 50% ±10% | 2.2 V | | | 10 | MHz |
| | | | 3 V | | | 16 | |
| t _{TB,cap} | Timer_B, capture timing | TB0, TB1, TB2 | 2.2 V/3 V | 20 | | | ns |



MSP430x22x2, MSP430x22x4 MIXED SIGNAL MICROCONTROLLER

SLAS504B – JULY 2006 – REVISED JULY 2007

electrical characteristics over recommended ranges of supply voltage and operating free-air temperature (unless otherwise noted) (continued)

USCI (UART Mode)

| PARAMETER | TEST CONDITIONS | VCC | MIN | TYP | MAX | UNIT |
|---------------------|---|-----------|-----|---------------------|-----|------|
| f _{USCI} | USCI input clock frequency Internal: SMCLK, ACLK External: UCLK Duty cycle = 50% ± 10% | | | f _{SYSTEM} | | MHz |
| f _{BITCLK} | BITCLK clock frequency (equals baud rate in MBaud) | 2.2V /3 V | | | 1 | MHz |
| t _τ | UART receive deglitch time (see Note 1) | 2.2 V | 50 | 150 | 600 | ns |
| | | 3 V | 50 | 100 | 600 | ns |

NOTES: 1. Pulses on the UART receive input (UCxRX) shorter than the UART receive deglitch time are suppressed. To ensure that pulses are correctly recognized, their width should exceed the maximum specification of the deglitch time.

USCI (SPI Master Mode, see Figure 20 and Figure 21)

| PARAMETER | TEST CONDITIONS | VCC | MIN | TYP | MAX | UNIT |
|-----------------------|---|-------|-----|---------------------|-----|------|
| f _{USCI} | USCI input clock frequency SMCLK, ACLK Duty cycle = 50% ± 10% | | | f _{SYSTEM} | | MHz |
| t _{SU,MI} | SOMI input data setup time | 2.2 V | 110 | | | ns |
| | | 3 V | 75 | | | |
| t _{HD,MI} | SOMI input data hold time | 2.2 V | 0 | | | ns |
| | | 3 V | 0 | | | |
| t _{VALID,MO} | SIMO output data valid time C _L = 20 pF | 2.2 V | | | 30 | ns |
| | | 3 V | | | 20 | |

NOTE: $f_{UCxCLK} = \frac{1}{2t_{LO/HI}}$ with $t_{LO/HI} \geq \max(t_{VALID,MO}(USCI) + t_{SU,SI}(Slave), t_{SU,MI}(USCI) + t_{VALID,SO}(Slave))$.

For the slave's parameters t_{SU,SI(Slave)} and t_{VALID,SO(Slave)}, see the SPI parameters of the attached slave.

USCI (SPI Slave Mode, see Figure 22 and Figure 23)

| PARAMETER | TEST CONDITIONS | VCC | MIN | TYP | MAX | UNIT |
|-----------------------|---|-----------|-----|-----|-----|------|
| t _{STE,LEAD} | STE lead time STE low to clock | 2.2 V/3 V | | 50 | | ns |
| t _{STE,LAG} | STE lag time Last clock to STE high | 2.2 V/3 V | 10 | | | ns |
| t _{STE,ACC} | STE access time STE low to SOMI data out | 2.2 V/3 V | | 50 | | ns |
| t _{STE,DIS} | STE disable time STE high to SOMI high impedance | 2.2 V/3 V | | 50 | | ns |
| t _{SU,SI} | SIMO input data setup time | 2.2 V | 20 | | | ns |
| | | 3 V | 15 | | | |
| t _{HD,SI} | SIMO input data hold time | 2.2 V | 10 | | | ns |
| | | 3 V | 10 | | | |
| t _{VALID,SO} | SOMI output data valid time C _L = 20 pF | 2.2 V | | 75 | 110 | ns |
| | | 3 V | | 50 | 75 | |

NOTE: $f_{UCxCLK} = \frac{1}{2t_{LO/HI}}$ with $t_{LO/HI} \geq \max(t_{VALID,MO}(Master) + t_{SU,SI}(USCI), t_{SU,MI}(Master) + t_{VALID,SO}(USCI))$.

For the master's parameters t_{SU,MI(Master)} and t_{VALID,MO(Master)}, see the SPI parameters of the attached master.



electrical characteristics over recommended ranges of supply voltage and operating free-air temperature (unless otherwise noted) (continued)

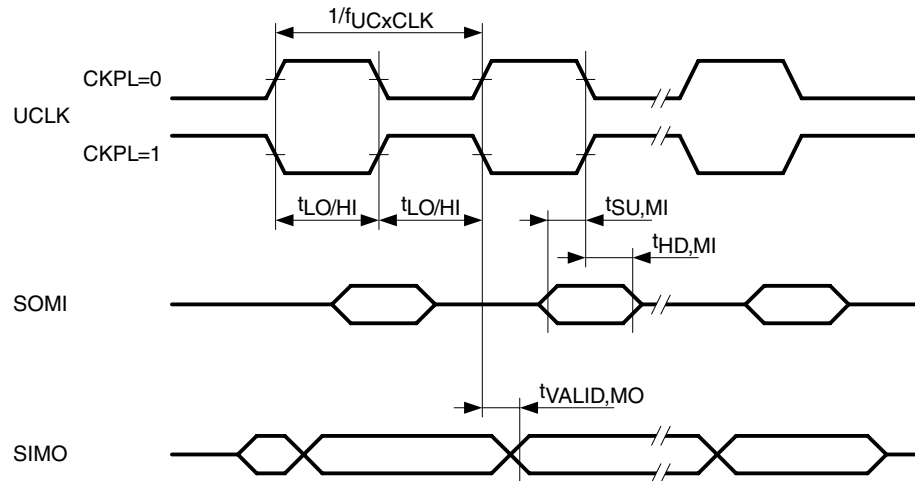

Figure 20. SPI Master Mode, CKPH = 0

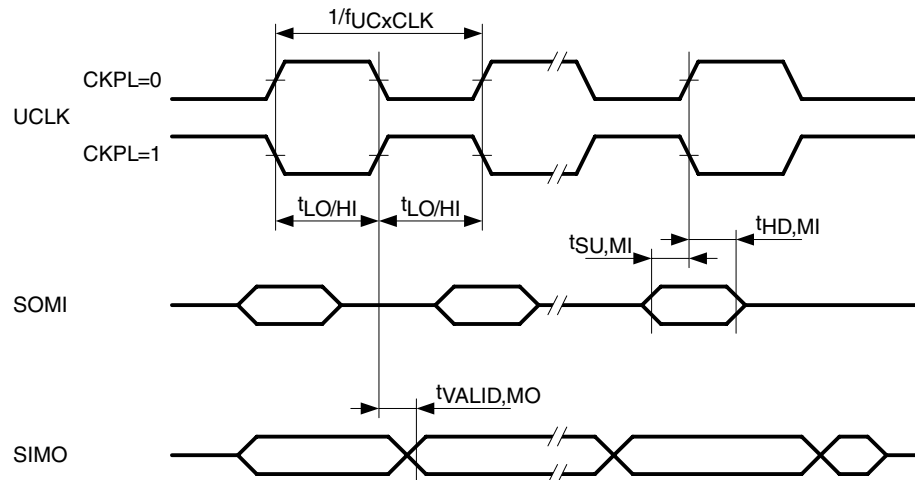

Figure 21. SPI Master Mode, CKPH = 1

MSP430x22x2, MSP430x22x4 MIXED SIGNAL MICROCONTROLLER

SLAS504B – JULY 2006 – REVISED JULY 2007

electrical characteristics over recommended ranges of supply voltage and operating free-air temperature (unless otherwise noted) (continued)

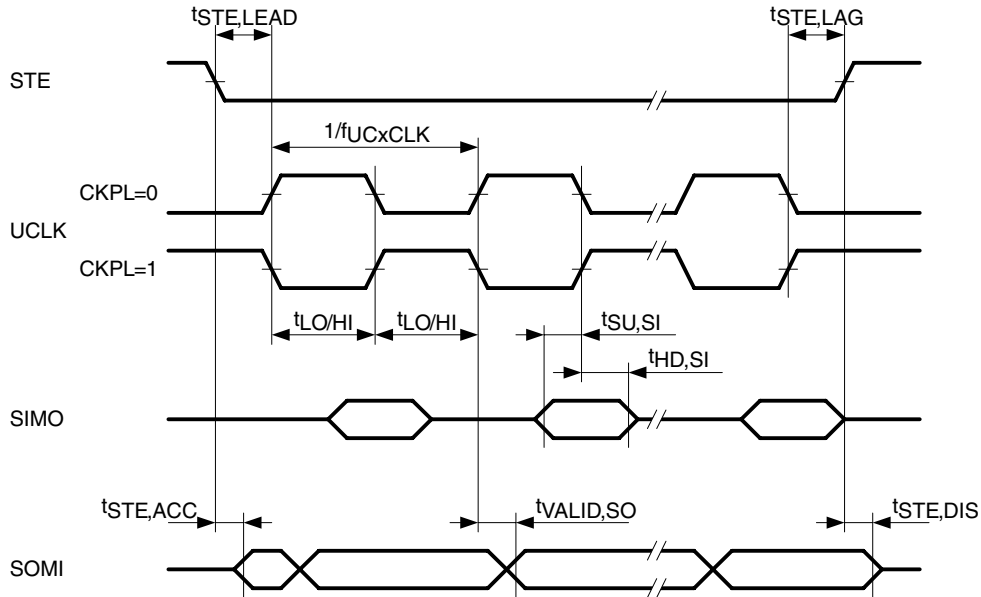

Figure 22. SPI Slave Mode, CKPH = 0

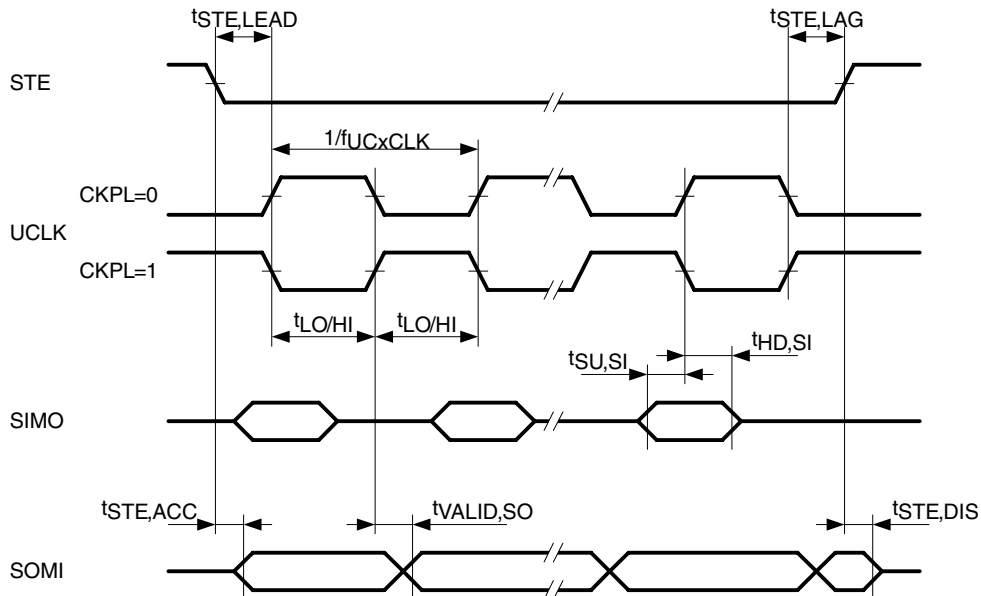

Figure 23. SPI Slave Mode, CKPH = 1

electrical characteristics over recommended ranges of supply voltage and operating free-air temperature (unless otherwise noted) (continued)

USCI (I2C Mode) (see Figure 24)

| PARAMETER | TEST CONDITIONS | VCC | MIN | TYP | MAX | UNIT |
|--------------|--|------------------------|-----------|--------------|-----|---------|
| f_{USCI} | USCI input clock frequency | | | f_{SYSTEM} | | MHz |
| f_{SCL} | SCL clock frequency | 2.2 V/3 V | 0 | | 400 | kHz |
| $t_{HD,STA}$ | Hold time (repeated) START | $f_{SCL} \leq 100$ kHz | 2.2 V/3 V | 4.0 | | μ s |
| | | $f_{SCL} > 100$ kHz | 2.2 V/3 V | 0.6 | | |
| $t_{SU,STA}$ | Setup time for a repeated START | $f_{SCL} \leq 100$ kHz | 2.2 V/3 V | 4.7 | | μ s |
| | | $f_{SCL} > 100$ kHz | 2.2 V/3 V | 0.6 | | |
| $t_{HD,DAT}$ | Data hold time | 2.2 V/3 V | 0 | | | ns |
| $t_{SU,DAT}$ | Data setup time | 2.2 V/3 V | 250 | | | ns |
| $t_{SU,STO}$ | Setup time for STOP | 2.2 V/3 V | 4.0 | | | μ s |
| t_{SP} | Pulse width of spikes suppressed by input filter | 2.2 V | 50 | 150 | 600 | ns |
| | | 3 V | 50 | 100 | 600 | |

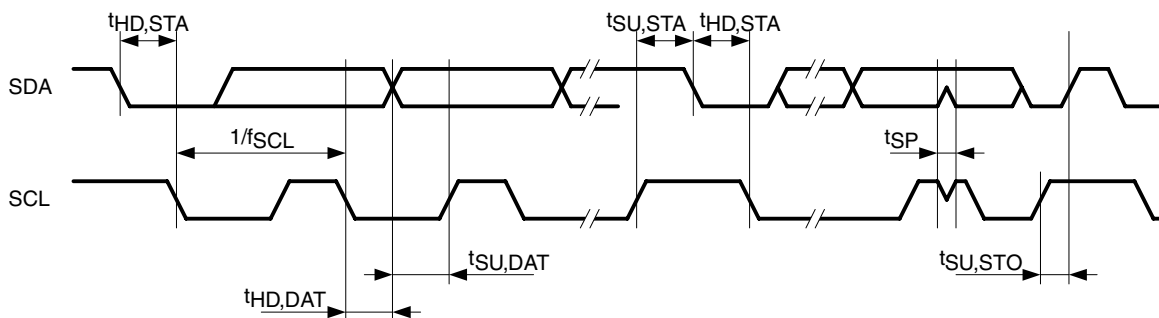

Figure 24. I2C Mode Timing

MSP430x22x2, MSP430x22x4 MIXED SIGNAL MICROCONTROLLER

SLAS504B – JULY 2006 – REVISED JULY 2007

electrical characteristics over recommended ranges of supply voltage and operating free-air temperature (unless otherwise noted) (continued)

10-bit ADC, power supply and input range conditions (see Note 1)

| PARAMETER | TEST CONDITIONS | T _A | V _{CC} | MIN | TYP | MAX | UNIT |
|---------------------|--|--|-----------------------------|------------------------|------|-----------------|------|
| V _{CC} | Analog supply voltage range | V _{SS} = 0 V | | 2.2 | | 3.6 | V |
| V _{Ax} | Analog input voltage range (see Note 2) | All Ax terminals. Analog inputs selected in ADC10AE register | | 0 | | V _{CC} | V |
| I _{ADC10} | ADC10 supply current (see Note 3) | f _{ADC10CLK} = 5.0 MHz ADC10ON = 1, REFON = 0, ADC10SHT0 = 1, ADC10SHT1 = 0, ADC10DIV = 0 | I: -40–85°C T: -40–105°C | 2.2 V | 0.52 | 1.05 | mA |
| | | | | 3 V | 0.6 | 1.2 | |
| I _{REF+} | Reference supply current, reference buffer disabled (see Note 4) | f _{ADC10CLK} = 5.0 MHz, ADC10ON = 0, REF2_5V = 0, REFON = 1, REFOUT = 0 | I: -40–85°C T: -40–105°C | 2.2 V/3 V | 0.25 | 0.4 | mA |
| | | f _{ADC10CLK} = 5.0 MHz, ADC10ON = 0, REF2_5V = 1, REFON = 1, REFOUT = 0 | I: -40–85°C T: -40–105°C | 3 V | | | |
| I _{REFB,0} | Reference buffer supply current with ADC10SR = 0 (see Note 4) | f _{ADC10CLK} = 5.0 MHz, ADC10ON = 0, REFON = 1, REF2_5V = 0, REFOUT = 1, ADC10SR=0 | -40–85°C 105°C | 2.2 V/3 V 2.2 V/3 V | 1.1 | 1.4 1.8 | mA |
| | | | | | | | |
| I _{REFB,1} | Reference buffer supply current with ADC10SR = 1 (see Note 4) | f _{ADC10CLK} = 5.0 MHz, ADC10ON = 0, REFON = 1, REF2_5V = 0, REFOUT = 1, ADC10SR=1 | -40–85°C 105°C | 2.2 V/3 V 2.2 V/3 V | 0.5 | 0.7 0.8 | mA |
| | | | | | | | |
| C _I | Input capacitance | Only one terminal Ax selected at a time | I: -40–85°C T: -40–105°C | | | 27 | pF |
| R _I | Input MUX ON resistance | 0V ≤ V _{Ax} ≤ V _{CC} | I: -40–85°C T: -40–105°C | 2.2 V/3 V | | 2000 | Ω |

- NOTES: 1. The leakage current is defined in the leakage current table with P_{x.x}/A_x parameter.
 2. The analog input voltage range must be within the selected reference voltage range V_{R+} to V_{R-} for valid conversion results.
 3. The internal reference supply current is not included in current consumption parameter I_{ADC10}.
 4. The internal reference current is supplied via terminal V_{CC}. Consumption is independent of the ADC10ON control bit, unless a conversion is active. The REFON bit enables the built-in reference to settle before starting an A/D conversion.



electrical characteristics over recommended ranges of supply voltage and operating free-air temperature (unless otherwise noted) (continued)

10-bit ADC, built-in voltage reference

| PARAMETER | TEST CONDITIONS | | VCC | MIN | TYP | MAX | UNIT |
|---|--|--|-----------|------|-----|------|--------|
| V _{CC,REF+} | Positive built-in reference analog supply voltage range | I _{VREF+} ≤ 1 mA, REF2_5V = 0 | | 2.2 | | | V |
| | | I _{VREF+} ≤ 0.5 mA, REF2_5V = 1 | | 2.8 | | | |
| | | I _{VREF+} ≤ 1 mA, REF2_5V = 1 | | 2.9 | | | |
| V _{REF+} | Positive built-in reference voltage | I _{VREF+} ≤ I _{VREF+,max} , REF2_5V = 0 | 2.2 V/3 V | 1.41 | 1.5 | 1.59 | V |
| | | I _{VREF+} ≤ I _{VREF+,max} , REF2_5V = 1 | 3 V | 2.35 | 2.5 | 2.65 | |
| I _{LD,VREF+} | Maximum V _{REF+} load current | | 2.2 V | ±0.5 | | | mA |
| | | | 3 V | ±1 | | | |
| V _{REF+} load regulation | | I _{VREF+} = 500 μA ± 100 μA, Analog input voltage V _{Ax} ≈ 0.75 V, REF2_5V = 0 | 2.2 V/3 V | ±2 | | | LSB |
| | | I _{VREF+} = 500 μA ± 100 μA, Analog input voltage V _{Ax} ≈ 1.25 V, REF2_5V = 1 | 3 V | ±2 | | | |
| V _{REF+} load regulation response time | | I _{VREF+} = 100 μA → 900 μA, V _{Ax} ≈ 0.5 x V _{REF+} , Error of conversion result ≤ 1 LSB | 3 V | | | 400 | ns |
| | | | | | | 2000 | |
| C _{VREF+} | Max. capacitance at pin V _{REF+} (see Note 1) | I _{VREF+} ≤ ±1 mA, REFON = 1, REFOUT = 1 | 2.2 V/3 V | 100 | | | pF |
| TC _{REF+} | Temperature coefficient | I _{VREF+} = const. with 0 mA ≤ I _{VREF+} ≤ 1 mA | 2.2 V/3 V | ±100 | | | ppm/°C |
| t _{REFON} | Settling time of internal reference voltage (see Note 2) | I _{VREF+} = 0.5 mA, REF2_5V = 0, REFON = 0 → 1 | 3.6 V | 30 | | | μs |
| t _{REFBURST} | Settling time of reference buffer (see Note 2) | I _{VREF+} = 0.5 mA, REF2_5V = 0, REFON = 1, REFBURST = 1 | 2.2 V | | | 1 | μs |
| | | | | | | 2.5 | |
| | | I _{VREF+} = 0.5 mA, REF2_5V = 1, REFON = 1, REFBURST = 1 | 3 V | | | 2 | |
| | | | | | | 4.5 | |

- NOTES: 1. The capacitance applied to the internal buffer operational amplifier, if switched to terminal P2.4/TA2/A4/V_{REF+}/V_{eREF+} (REFOUT=1), must be limited; the reference buffer may become unstable otherwise.
2. The condition is that the error in a conversion started after t_{REFON} or t_{RefBuf} is less than ±0.5 LSB.

MSP430x22x2, MSP430x22x4 MIXED SIGNAL MICROCONTROLLER

SLAS504B – JULY 2006 – REVISED JULY 2007

electrical characteristics over recommended ranges of supply voltage and operating free-air temperature (unless otherwise noted) (continued)

10-bit ADC, external reference (see Note 1)

| PARAMETER | TEST CONDITIONS | VCC | MIN | TYP | MAX | UNIT |
|---|--|-----------|-----|-----|-----------------|------|
| V _{eREF+} Positive external reference input voltage range (see Note 2) | V _{eREF+} > V _{eREF-} , SREF1 = 1, SREF0 = 0 | | 1.4 | | V _{CC} | V |
| | V _{eREF-} ≤ V _{eREF+} ≤ V _{CC} - 0.15 V, SREF1 = 1, SREF0 = 1 (see Note 3) | | 1.4 | | 3.0 | |
| V _{eREF-} Negative external reference input voltage range (see Note 4) | V _{eREF+} > V _{eREF-} | | 0 | | 1.2 | V |
| ΔV _{eREF} Differential external reference input voltage range ΔV _{eREF} = V _{eREF+} - V _{eREF-} | V _{eREF+} > V _{eREF-} (see Note 5) | | 1.4 | | V _{CC} | V |
| I _{VeREF+} Static input current into V _{eREF+} | 0V ≤ V _{eREF+} ≤ V _{CC} , SREF1 = 1, SREF0 = 0 | 2.2 V/3 V | | | ±1 | μA |
| | 0V ≤ V _{eREF+} ≤ V _{CC} - 0.15 V ≤ 3 V, SREF1 = 1, SREF0 = 1 (see Note 3) | | | | 0 | |
| I _{VeREF-} Static input current into V _{eREF-} | 0V ≤ V _{eREF-} ≤ V _{CC} | 2.2 V/3 V | | | ±1 | μA |

- NOTES: 1. The external reference is used during conversion to charge and discharge the capacitance array. The input capacitance, C_I, is also the dynamic load for an external reference during conversion. The dynamic impedance of the reference supply should follow the recommendations on analog-source impedance to allow the charge to settle for 10-bit accuracy.
2. The accuracy limits the minimum positive external reference voltage. Lower reference voltage levels may be applied with reduced accuracy requirements.
3. Under this condition, the external reference is internally buffered. The reference buffer is active and requires the reference buffer supply current I_{REFB}. The current consumption can be limited to the sample and conversion period with REBURST = 1.
4. The accuracy limits the maximum negative external reference voltage. Higher reference voltage levels may be applied with reduced accuracy requirements.
5. The accuracy limits the minimum external differential reference voltage. Lower differential reference voltage levels may be applied with reduced accuracy requirements.



electrical characteristics over recommended ranges of supply voltage and operating free-air temperature (unless otherwise noted) (continued)

10-bit ADC, timing parameters

| PARAMETER | | TEST CONDITIONS | VCC | MIN | TYP | MAX | UNIT |
|-----------------------|-------------------------------------|--|-----------|---|-----|-----------|------|
| f _{ADC10CLK} | ADC10 input clock frequency | For specified performance of ADC10 linearity parameters | 2.2 V/3 V | 0.45 | | 6.3 | MHz |
| | | | | | | ADC10SR=0 | |
| | | ADC10SR=1 | | 0.45 | | | |
| f _{ADC10OSC} | ADC10 built-in oscillator frequency | ADC10DIVx = 0, ADC10SSELx = 0, f _{ADC10CLK} = f _{ADC10OSC} | 2.2 V/3 V | 3.7 | | 6.3 | MHz |
| t _{CONVERT} | Conversion time | ADC10 built-in oscillator, ADC10SSELx = 0, f _{ADC10CLK} = f _{ADC10OSC} | 2.2 V/3 V | 2.06 | | 3.51 | μs |
| | | f _{ADC10CLK} from ACLK, MCLK or SMCLK, ADC10SSELx ≠ 0 | | 13× ADC10DIVx 1/f _{ADC10CLK} | | | |
| t _{ADC10ON} | Turn on settling time of the ADC | (see Note 1) | | | | 100 | ns |

NOTES: 1. The condition is that the error in a conversion started after t_{ADC10ON} is less than ±0.5 LSB. The reference and input signal are already settled.

10-bit ADC, linearity parameters

| PARAMETER | | TEST CONDITIONS | VCC | MIN | TYP | MAX | UNIT |
|----------------|------------------------------|---|-----------|-----|------|-----|------|
| E _I | Integral linearity error | | 2.2 V/3 V | | | ±1 | LSB |
| E _D | Differential linearity error | | 2.2 V/3 V | | | ±1 | LSB |
| E _O | Offset error | Source impedance R _S < 100 Ω, | 2.2 V/3 V | | | ±1 | LSB |
| E _G | Gain error | SREFx = 010, unbuffered external reference, V _{eREF+} = 1.5 V | 2.2 V | | ±1.1 | ±2 | LSB |
| | | SREFx = 010, unbuffered external reference, V _{eREF+} = 2.5 V | 3 V | | ±1.1 | ±2 | |
| | | SREFx = 011, buffered external reference (see Note 1), V _{eREF+} = 1.5 V | 2.2 V | | ±1.1 | ±4 | |
| | | SREFx = 011, buffered external reference (see Note 1), V _{eREF+} = 2.5 V | 3 V | | ±1.1 | ±3 | |
| E _T | Total unadjusted error | SREFx = 010, unbuffered external reference, V _{eREF+} = 1.5 V | 2.2 V | | ±2 | ±5 | LSB |
| | | SREFx = 010, unbuffered external reference, V _{eREF+} = 2.5 V | 3 V | | ±2 | ±5 | |
| | | SREFx = 011, buffered external reference (see Note 1), V _{eREF+} = 1.5 V | 2.2 V | | ±2 | ±7 | |
| | | SREFx = 011, buffered external reference (see Note 1), V _{eREF+} = 2.5 V | 3 V | | ±2 | ±6 | |

NOTES: 1. The reference buffer offset adds to the gain and total unadjusted error.

MSP430x22x2, MSP430x22x4 MIXED SIGNAL MICROCONTROLLER

SLAS504B – JULY 2006 – REVISED JULY 2007

electrical characteristics over recommended ranges of supply voltage and operating free-air temperature (unless otherwise noted) (continued)

10-bit ADC, temperature sensor and built-in V_{MID}

| PARAMETER | | TEST CONDITIONS | VCC | MIN | TYP | MAX | UNIT |
|-----------------------|---|---|-----------|------|------|------|----------------------------|
| I_{SENSOR} | Temperature sensor supply current (see Note 1) | REFON = 0, INCHx = 0Ah, $T_A = 25^\circ\text{C}$ | 2.2 V | | 40 | 120 | μA |
| | | | 3 V | | 60 | 160 | |
| TC_{SENSOR}^\dagger | | ADC10ON = 1, INCHx = 0Ah (see Note 2) | 2.2 V/3 V | 3.44 | 3.55 | 3.66 | $\text{mV}/^\circ\text{C}$ |
| $V_{Offset, Sensor}$ | Sensor offset voltage | ADC10ON = 1, INCHx = 0Ah (see Note 2) | | -100 | | 100 | mV |
| V_{Sensor} | Sensor output voltage (see Note 3) | Temperature sensor voltage at $T_A = 105^\circ\text{C}$ (T version only) | 2.2 V/3 V | 1265 | 1365 | 1465 | mV |
| | | Temperature sensor voltage at $T_A = 85^\circ\text{C}$ | 2.2 V/3 V | 1195 | 1295 | 1395 | |
| | | Temperature sensor voltage at $T_A = 25^\circ\text{C}$ | 2.2 V/3 V | 985 | 1085 | 1185 | |
| | | Temperature sensor voltage at $T_A = 0^\circ\text{C}$ | 2.2 V/3 V | 895 | 995 | 1095 | |
| $t_{Sensor(sample)}$ | Sample time required if channel 10 is selected (see Note 4) | ADC10ON = 1, INCHx = 0Ah, Error of conversion result ≤ 1 LSB | 2.2 V/3 V | 30 | | | μs |
| I_{VMID} | Current into divider at channel 11 (see Note 5) | ADC10ON = 1, INCHx = 0Bh | 2.2 V | | | NA | μA |
| | | | 3 V | | | NA | |
| V_{MID} | V_{CC} divider at channel 11 | ADC10ON = 1, INCHx = 0Bh, V_{MID} is $\approx 0.5 \times V_{CC}$ | 2.2 V | 1.06 | 1.1 | 1.14 | V |
| | | | 3 V | 1.46 | 1.5 | 1.54 | |
| $t_{VMID(sample)}$ | Sample time required if channel 11 is selected (see Note 6) | ADC10ON = 1, INCHx = 0Bh, Error of conversion result ≤ 1 LSB | 2.2 V | 1400 | | | ns |
| | | | 3 V | 1220 | | | |

- NOTES: 1. The sensor current I_{SENSOR} is consumed if (ADC10ON = 1 and REFON = 1), or (ADC10ON = 1 and INCH = 0Ah and sample signal is high). When REFON = 1, I_{SENSOR} is included in I_{REF+} . When REFON = 0, I_{SENSOR} applies during conversion of the temperature sensor input (INCH = 0Ah).
2. The following formula can be used to calculate the temperature sensor output voltage:
 $V_{Sensor,typ} = TC_{Sensor} (273 + T [^\circ\text{C}]) + V_{Offset,sensor} [\text{mV}]$ or
 $V_{Sensor,typ} = TC_{Sensor} T [^\circ\text{C}] + V_{Sensor}(T_A = 0^\circ\text{C}) [\text{mV}]$
3. Results based on characterization and/or production test, not TC_{Sensor} or $V_{Offset,sensor}$.
4. The typical equivalent impedance of the sensor is 51 k Ω . The sample time required includes the sensor-on time $t_{SENSOR(on)}$.
5. No additional current is needed. The V_{MID} is used during sampling.
6. The on time, $t_{VMID(on)}$, is included in the sampling time, $t_{VMID(sample)}$; no additional on time is needed.



electrical characteristics over recommended ranges of supply voltage and operating free-air temperature (unless otherwise noted) (continued)

operational amplifier OA, supply specifications (MSP430x22x4 only)

| PARAMETER | TEST CONDITIONS | VCC | MIN | TYP | MAX | UNIT | |
|-----------------|------------------------------|-----------|-----|-------------|-----|------|----|
| V _{CC} | Supply voltage range | | 2.2 | | 3.6 | V | |
| I _{CC} | Supply current (see Note 1) | 2.2 V/3 V | | Fast Mode | 180 | 290 | μA |
| | | | | Medium Mode | 110 | 190 | |
| | | | | Slow Mode | 50 | 80 | |
| PSRR | Power supply rejection ratio | 2.2 V/3 V | | 70 | | dB | |

NOTES: 1. Corresponding pins configured as OA inputs and outputs respectively.

operational amplifier OA, input/output specifications (MSP430x22x4 only)

| PARAMETER | TEST CONDITIONS | VCC | MIN | TYP | MAX | UNIT | | |
|-----------------------|--|-----------|------|---|----------------------|-----------------|-----|--------|
| V _{I/P} | Input voltage range | | -0.1 | V _{CC} -1.2 | | V | | |
| I _{lkg} | Input leakage current (see Notes 1 and 2) | 2.2 V/3 V | | T _A = -40 to +55°C | -5 | ±0.5 | 5 | nA |
| | | | | T _A = +55 to +85°C | -20 | ±5 | 20 | |
| | | | | T _A = +85 to +105°C | -50 | | 50 | |
| V _n | Voltage noise density, I/P | 2.2 V/3 V | | f _{V(I/P)} = 1 kHz | Fast Mode | | 50 | nV/√Hz |
| | | | | | Medium Mode | | 80 | |
| | | | | | Slow Mode | | 140 | |
| | | | | f _{V(I/P)} = 10 kHz | Fast Mode | | 30 | |
| | | | | | Medium Mode | | 50 | |
| | | | | | Slow Mode | | 65 | |
| V _{IO} | Offset voltage, I/P | 2.2 V/3 V | | | ±10 | mV | | |
| | Offset temperature drift, I/P | 2.2 V/3 V | | ±10 | | μV/°C | | |
| | Offset voltage drift with supply, I/P | 2.2 V/3 V | | | ±1.5 | mV/V | | |
| V _{OH} | High-level output voltage, O/P | 2.2 V/3 V | | Fast Mode, I _{SOURCE} ≤ -500 μA | V _{CC} -0.2 | V _{CC} | V | |
| | | | | Slow Mode, I _{SOURCE} ≤ -150 μA | V _{CC} -0.1 | V _{CC} | | |
| V _{OL} | Low-level output voltage, O/P | 2.2 V/3 V | | Fast Mode, I _{SOURCE} ≤ +500 μA | V _{SS} | 0.2 | V | |
| | | | | Slow Mode, I _{SOURCE} ≤ +150 μA | V _{SS} | 0.1 | | |
| R _{O/P(OAx)} | Output resistance (see Figure 25 and Note 4) | 2.2 V/3 V | | R _{Load} = 3 kΩ, C _{Load} = 50pF, V _{O/P(OAx)} < 0.2 V | | 150 | 250 | Ω |
| | | | | R _{Load} = 3 kΩ, C _{Load} = 50pF, V _{O/P(OAx)} > V _{CC} - 1.2 V | | 150 | 250 | |
| | | | | R _{Load} = 3 kΩ, C _{Load} = 50pF, 0.2 V ≤ V _{O/P(OAx)} ≤ V _{CC} - 0.2 V | | 0.1 | 4 | |
| CMRR | Common-mode rejection ratio | 2.2 V/3 V | | 70 | | dB | | |

- NOTES: 1. ESD damage can degrade input current leakage.
 2. The input bias current is overridden by the input leakage current.
 3. Calculated using the box method
 4. Specification valid for voltage-follower OAx configuration



MSP430x22x2, MSP430x22x4 MIXED SIGNAL MICROCONTROLLER

SLAS504B – JULY 2006 – REVISED JULY 2007

electrical characteristics over recommended ranges of supply voltage and operating free-air temperature (unless otherwise noted) (continued)

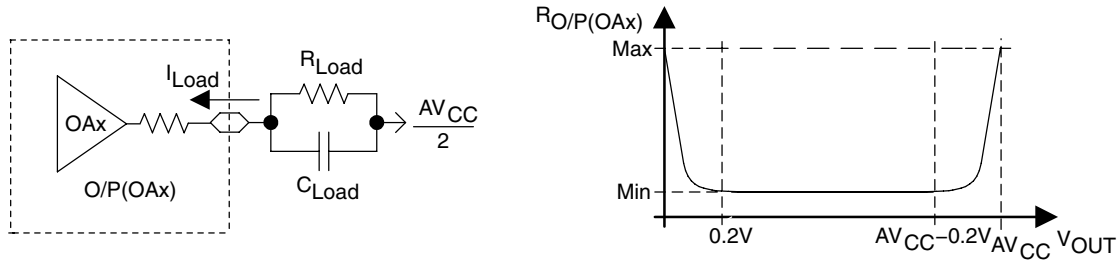

Figure 25. OAx Output Resistance Tests

operational amplifier OA, dynamic specifications (MSP430x22x4 only)

| PARAMETER | TEST CONDITIONS | VCC | MIN | TYP | MAX | UNIT | |
|----------------------|---|--|-----------|-----|-----|------|----|
| SR | Fast Mode | 2.2 V/3 V | | 1.2 | | V/μs | |
| | Medium Mode | | | 0.8 | | | |
| | Slow Mode | | | 0.3 | | | |
| | Open-loop voltage gain | | | 100 | | dB | |
| φ _m | Phase margin | C _L = 50 pF | | 60 | | deg | |
| | Gain margin | C _L = 50 pF | | 20 | | dB | |
| GBW | Noninverting, Fast Mode, R _L = 47 kΩ, C _L = 50 pF | 2.2 V/3 V | | 2.2 | | MHz | |
| | Noninverting, Medium Mode, R _L = 300 kΩ, C _L = 50 pF | | | 1.4 | | | |
| | Non-inverting, Slow Mode, R _L = 300 kΩ, C _L = 50 pF | | | 0.5 | | | |
| t _{en(on)} | Enable time on | t _{on} , Noninverting, Gain = 1 | 2.2 V/3 V | | 10 | 20 | μs |
| t _{en(off)} | Enable time off | | 2.2 V/3 V | | | 1 | μs |

TYPICAL OPEN-LOOP GAIN vs FREQUENCY

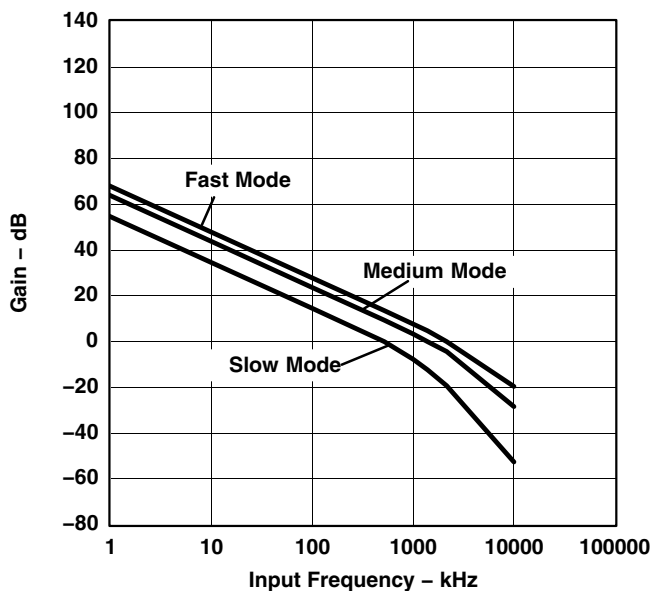

Figure 26

TYPICAL PHASE vs FREQUENCY

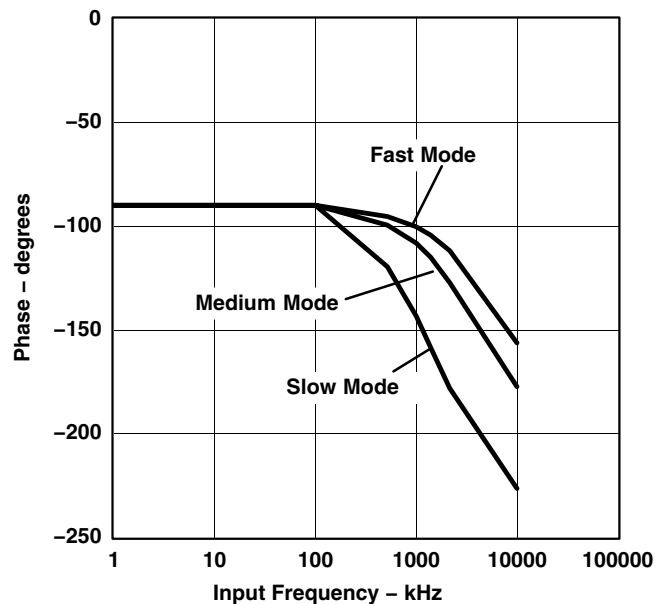

Figure 27



electrical characteristics over recommended ranges of supply voltage and operating free-air temperature (unless otherwise noted) (continued)

operational amplifier OA feedback network, resistor network (see Note 1) (MSP430x22x4 only)

| PARAMETER | TEST CONDITIONS | VCC | MIN | TYP | MAX | UNIT |
|--------------------|---|-----|-----|-----|-----|------|
| R _{total} | Total resistance of resistor string | | 76 | 96 | 128 | kΩ |
| R _{unit} | Unit resistor of resistor string (see Note 2) | | 4.8 | 6 | 8 | kΩ |

NOTES: 1. A single resistor string is composed of 4 R_{unit} + 4 R_{unit} + 2 R_{unit} + 2 R_{unit} + 1 R_{unit} + 1 R_{unit} + 1 R_{unit} + 1 R_{unit} = 16 R_{unit} = R_{total}.
2. For the matching (i.e. the relative accuracy) of the unit resistors on a device refer to the gain and level specifications of the respective configurations.

operational amplifier OA feedback network, comparator mode (OAF_{Cx} = 3) (MSP430x22x4 only)

| PARAMETER | TEST CONDITIONS | VCC | MIN | TYP | MAX | UNIT | | | | |
|-------------------------------|------------------|------------|-----|-----|-----|-----------------|-------------------------------------|---|------------|-------|
| V _{Level} | Comparator level | 2.2 V/ 3 V | | | | V _{CC} | | | | |
| | | | | | | | OAFBR _x = 1, OARRIP = 0 | 0.245 | 1/4 | 0.255 |
| | | | | | | | OAFBR _x = 2, OARRIP = 0 | 0.495 | 1/2 | 0.505 |
| | | | | | | | OAFBR _x = 3, OARRIP = 0 | 0.619 | 5/8 | 0.631 |
| | | | | | | | OAFBR _x = 4, OARRIP = 0 | N/A (see Note 1) | | |
| | | | | | | | OAFBR _x = 5, OARRIP = 0 | N/A (see Note 1) | | |
| | | | | | | | OAFBR _x = 6, OARRIP = 0 | N/A (see Note 1) | | |
| | | | | | | | OAFBR _x = 7, OARRIP = 0 | N/A (see Note 1) | | |
| | | | | | | | OAFBR _x = 1, OARRIP = 1 | 0.061 | 1/16 | 0.065 |
| | | | | | | | OAFBR _x = 2, OARRIP = 1 | 0.122 | 1/8 | 0.128 |
| | | | | | | | OAFBR _x = 3, OARRIP = 1 | 0.184 | 3/16 | 0.192 |
| | | | | | | | OAFBR _x = 4, OARRIP = 1 | 0.245 | 1/4 | 0.255 |
| | | | | | | | OAFBR _x = 5, OARRIP = 1 | 0.367 | 3/8 | 0.383 |
| | | | | | | | OAFBR _x = 6, OARRIP = 1 | 0.495 | 1/2 | 0.505 |
| | | | | | | | OAFBR _x = 7, OARRIP = 1 | N/A (see Note 1) | | |
| | | | | | | | t _{PLH} , t _{PHL} | Propagation delay (low–high and high–low) | 2.2 V/ 3 V | |
| Fast Mode, Overdrive 10 mV | 40 | | | | | | | | | |
| Fast Mode, Overdrive 100 mV | 4 | | | | | | | | | |
| Fast Mode, Overdrive 500 mV | 3 | | | | | | | | | |
| Medium Mode, Overdrive 10 mV | 60 | | | | | | | | | |
| Medium Mode, Overdrive 100 mV | 6 | | | | | | | | | |
| Medium Mode, Overdrive 500 mV | 5 | | | | | | | | | |
| Slow Mode, Overdrive 10 mV | 160 | | | | | | | | | |
| Slow Mode, Overdrive 100 mV | 20 | | | | | | | | | |
| Slow Mode, Overdrive 500 mV | 15 | | | | | | | | | |

NOTES: 1. The level is not available due to the analog input voltage range of the operational amplifier.

MSP430x22x2, MSP430x22x4 MIXED SIGNAL MICROCONTROLLER

SLAS504B – JULY 2006 – REVISED JULY 2007

electrical characteristics over recommended ranges of supply voltage and operating free-air temperature (unless otherwise noted) (continued)

operational amplifier OA feedback network, noninverting amplifier mode (OAFc_x = 4) (MSP430x22x4 only)

| PARAMETER | TEST CONDITIONS | VCC | MIN | TYP | MAX | UNIT | |
|---------------------|--|-----------------|------------------------|-------|-------|-------|--|
| G | Gain | 2.2 V/ 3 V | OAFBR _x = 0 | 0.998 | 1.00 | 1.002 | |
| | | | OAFBR _x = 1 | 1.328 | 1.334 | 1.340 | |
| | | | OAFBR _x = 2 | 1.985 | 2.001 | 2.017 | |
| | | | OAFBR _x = 3 | 2.638 | 2.667 | 2.696 | |
| | | | OAFBR _x = 4 | 3.94 | 4.00 | 4.06 | |
| | | | OAFBR _x = 5 | 5.22 | 5.33 | 5.44 | |
| | | | OAFBR _x = 6 | 7.76 | 7.97 | 8.18 | |
| | | | OAFBR _x = 7 | 15.0 | 15.8 | 16.6 | |
| THD | Total harmonic distortion/ nonlinearity | All gains | 2.2 V | -60 | | dB | |
| | | | 3 V | -70 | | | |
| t _{Settle} | Settling time (see Note 1) | All power modes | 2.2 V/3 V | 7 | 12 | μs | |

NOTES: 1. The settling time specifies the time until an ADC result is stable. This includes the minimum required sampling time of the ADC. The settling time of the amplifier itself might be faster.

operational amplifier OA feedback network, inverting amplifier mode (OAFc_x = 6) (see Note 1) (MSP430x22x4 only)

| PARAMETER | TEST CONDITIONS | VCC | MIN | TYP | MAX | UNIT | |
|---------------------|--|-----------------|------------------------|--------|--------|--------|--|
| G | Gain | 2.2 V/ 3 V | OAFBR _x = 1 | -0.345 | -0.335 | -0.325 | |
| | | | OAFBR _x = 2 | -1.023 | -1.002 | -0.979 | |
| | | | OAFBR _x = 3 | -1.712 | -1.668 | -1.624 | |
| | | | OAFBR _x = 4 | -3.10 | -3.00 | -2.90 | |
| | | | OAFBR _x = 5 | -4.51 | -4.33 | -4.15 | |
| | | | OAFBR _x = 6 | -7.37 | -6.97 | -6.57 | |
| | | | OAFBR _x = 7 | -16.3 | -14.8 | -13.1 | |
| THD | Total harmonic distortion/ nonlinearity | All gains | 2.2 V | -60 | | dB | |
| | | | 3 V | -70 | | | |
| t _{Settle} | Settling time (see Note 2) | All power modes | 2.2 V/3 V | 7 | 12 | μs | |

NOTES: 1. This includes the 2 OA configuration “inverting amplifier with input buffer”. Both OA needs to be set to the same power mode OAPM_x.
2. The settling time specifies the time until an ADC result is stable. This includes the minimum required sampling time of the ADC. The settling time of the amplifier itself might be faster.



electrical characteristics over recommended ranges of supply voltage and operating free-air temperature (unless otherwise noted) (continued)

Flash Memory

| PARAMETER | | TEST CONDITIONS | VCC | MIN | TYP | MAX | UNIT |
|---------------------|---|--------------------------|-------------|--------|--------|-----|------------------|
| $V_{CC(PGM/ERASE)}$ | Program and erase supply voltage | | | 2.2 | | 3.6 | V |
| f_{FTG} | Flash timing generator frequency | | | 257 | | 476 | kHz |
| I_{PGM} | Supply current from V_{CC} during program | | 2.2 V/3.6 V | | 1 | 5 | mA |
| I_{ERASE} | Supply current from V_{CC} during erase | | 2.2 V/3.6 V | | 1 | 7 | mA |
| t_{CPT} | Cumulative program time (see Note 1) | | 2.2 V/3.6 V | | | 10 | ms |
| $t_{CMErase}$ | Cumulative mass erase time | | 2.2 V/3.6 V | 20 | | | ms |
| | Program/erase endurance | | | 10^4 | 10^5 | | cycles |
| $t_{Retention}$ | Data retention duration | $T_J = 25^\circ\text{C}$ | | 100 | | | years |
| t_{Word} | Word or byte program time | see Note 2 | | | 30 | | t _{FTG} |
| $t_{Block, 0}$ | Block program time for first byte or word | see Note 2 | | | 25 | | |
| $t_{Block, 1-63}$ | Block program time for each additional byte or word | see Note 2 | | | 18 | | |
| $t_{Block, End}$ | Block program end-sequence wait time | see Note 2 | | | 6 | | |
| $t_{Mass Erase}$ | Mass erase time | see Note 2 | | | 10593 | | |
| $t_{Seg Erase}$ | Segment erase time | see Note 2 | | | 4819 | | |

- NOTES: 1. The cumulative program time must not be exceeded when writing to a 64-byte flash block. This parameter applies to all programming methods: individual word/byte write and block write modes.
2. These values are hardwired into the flash controller's state machine ($t_{FTG} = 1/f_{FTG}$).

RAM

| PARAMETER | | TEST CONDITIONS | MIN | TYP | MAX | UNIT |
|--------------|---|-----------------|-----|-----|-----|------|
| $V_{(RAMh)}$ | RAM retention supply voltage (see Note 1) | CPU halted | 1.6 | | | V |

NOTE 1: This parameter defines the minimum supply voltage V_{CC} when the data in RAM remains unchanged. No program execution should happen during this supply voltage condition.

MSP430x22x2, MSP430x22x4 MIXED SIGNAL MICROCONTROLLER

SLAS504B – JULY 2006 – REVISED JULY 2007

electrical characteristics over recommended ranges of supply voltage and operating free-air temperature (unless otherwise noted) (continued)

JTAG and Spy-Bi-Wire Interface

| PARAMETER | | TEST CONDITIONS | VCC | MIN | TYP | MAX | UNIT |
|----------------|---|-----------------|-------------|-------|-----|-----|-----------|
| f_{SBW} | Spy-Bi-Wire input frequency | | 2.2 V / 3 V | 0 | | 20 | MHz |
| $t_{SBW,Low}$ | Spy-Bi-Wire low clock pulse length | | 2.2 V / 3 V | 0.025 | | 15 | μs |
| $t_{SBW,En}$ | Spy-Bi-Wire enable time (TEST high to acceptance of first clock edge, see Note 1) | | 2.2 V / 3 V | | | 1 | μs |
| $t_{SBW,Ret}$ | Spy-Bi-Wire return to normal operation time | | 2.2 V / 3 V | 15 | | 100 | μs |
| f_{TCK} | TCK input frequency (see Note 2) | | 2.2 V | 0 | | 5 | MHz |
| | | | 3 V | 0 | | 10 | |
| $R_{Internal}$ | Internal pull-down resistance on TEST | | 2.2 V / 3 V | 25 | 60 | 90 | $k\Omega$ |

- NOTES: 1. Tools accessing the Spy-Bi-Wire interface need to wait for the maximum $t_{SBW,En}$ time after pulling the TEST/SBWCLK pin high before applying the first SBWCLK clock edge.
2. f_{TCK} may be restricted to meet the timing requirements of the module selected.

JTAG Fuse (see Note 1)

| PARAMETER | | TEST CONDITIONS | VCC | MIN | TYP | MAX | UNIT |
|--------------|---|--------------------|-----|-----|-----|-----|------|
| $V_{CC(FB)}$ | Supply voltage during fuse-blow condition | $T_A = 25^\circ C$ | | 2.5 | | | V |
| V_{FB} | Voltage level on TEST for fuse blow | | | 6 | | 7 | V |
| I_{FB} | Supply current into TEST during fuse blow | | | | | 100 | mA |
| t_{FB} | Time to blow fuse | | | | | 1 | ms |

- NOTES: 1. Once the fuse is blown, no further access to the JTAG/Test and emulation feature is possible, and it is switched to bypass mode.



APPLICATION INFORMATION

Port P1 pin schematic: P1.0 to P1.3, input/output with Schmitt trigger

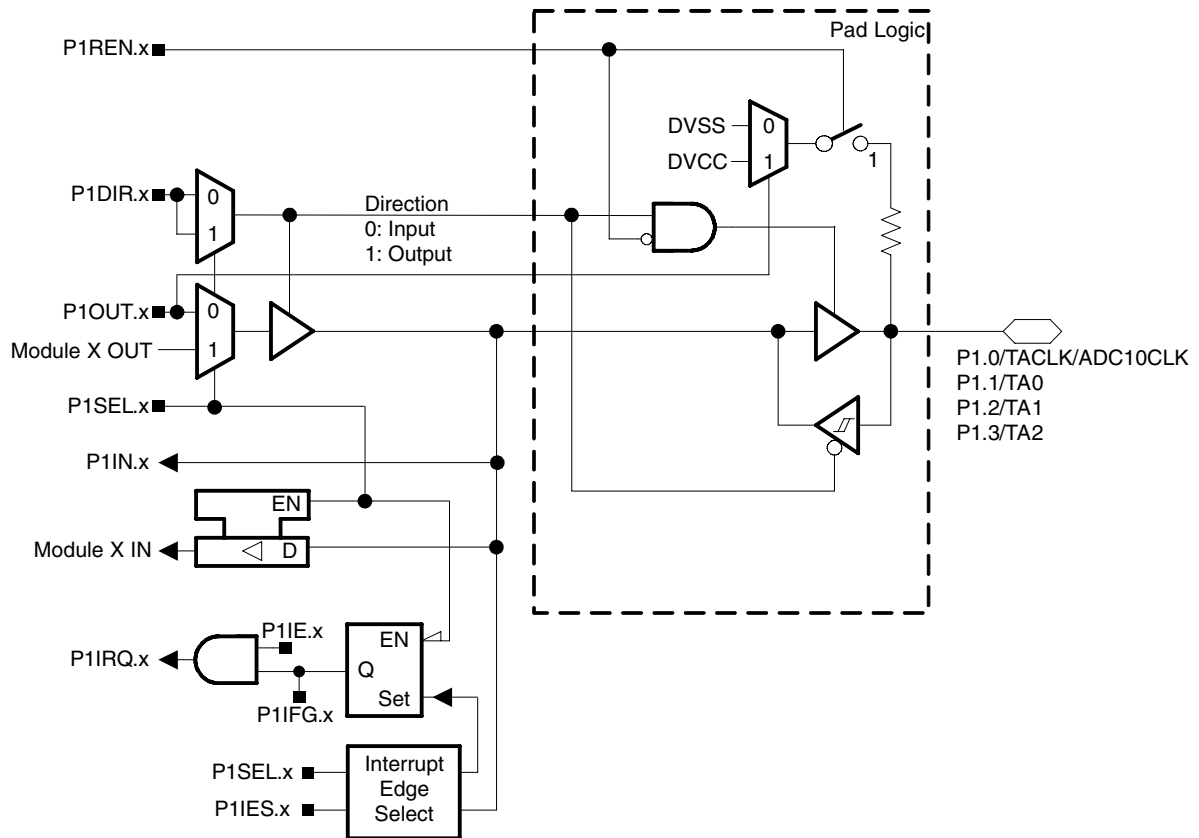

Port P1 (P1.0 to P1.3) pin functions

| PIN NAME (P1.X) | X | FUNCTION | CONTROL BITS / SIGNALS | |
|-------------------------|---|----------------|------------------------|---------|
| | | | P1DIR.x | P1SEL.x |
| P1.0/ TACLK/ADC10CLK | 0 | P1.0† (I/O) | I: 0; O: 1 | 0 |
| | | Timer_A3.TACLK | 0 | 1 |
| | | ADC10CLK | 1 | 1 |
| P1.1/TA0 | 1 | P1.1† (I/O) | I: 0; O: 1 | 0 |
| | | Timer_A3.CCI0A | 0 | 1 |
| | | Timer_A3.TA0 | 1 | 1 |
| P1.2/TA1 | 2 | P1.2† (I/O) | I: 0; O: 1 | 0 |
| | | Timer_A3.CCI0A | 0 | 1 |
| | | Timer_A3.TA0 | 1 | 1 |
| P1.3/TA2 | 3 | P1.3† (I/O) | I: 0; O: 1 | 0 |
| | | Timer_A3.CCI0A | 0 | 1 |
| | | Timer_A3.TA0 | 1 | 1 |

† Default after reset (PUC/POR)

- NOTES: 1. N/A: Not available or not applicable
2. X: Don't care

MSP430x22x2, MSP430x22x4 MIXED SIGNAL MICROCONTROLLER

SLAS504B – JULY 2006 – REVISED JULY 2007

Port P1 pin schematic: P1.4 to P1.6, input/output with Schmitt trigger and in-system access features

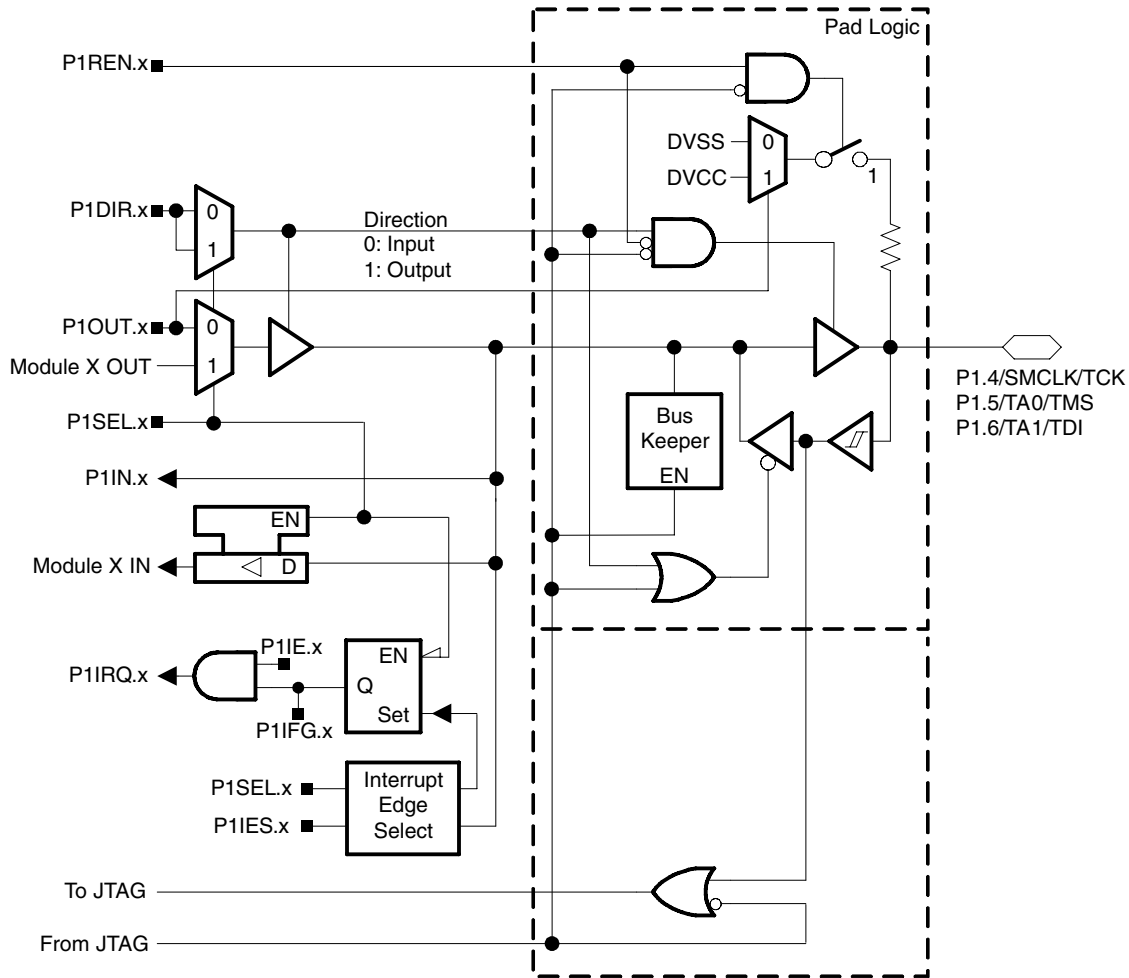

Port P1 (P1.4 to P1.6) pin functions

| PIN NAME (P1.X) | X | FUNCTION | CONTROL BITS / SIGNALS | | |
|-------------------|---|-----------------------|------------------------|---------|-------------|
| | | | P1DIR.x | P1SEL.x | 4-Wire JTAG |
| P1.4/SMCLK/TCK | 4 | P1.4† (I/O) | I: 0; O: 1 | 0 | 0 |
| | | SMCLK | 1 | 1 | 0 |
| | | TCK | X | X | 1 |
| P1.5/TA0/TMS | 5 | P1.5† (I/O) | I: 0; O: 1 | 0 | 0 |
| | | Timer_A3.TA0 | 1 | 1 | 0 |
| | | TMS | X | X | 1 |
| P1.6/TA1/TDI/TCLK | 6 | P1.6† (I/O) | I: 0; O: 1 | 0 | 0 |
| | | Timer_A3.TA1 | 1 | 1 | 0 |
| | | TDI/TCLK (see Note 3) | X | X | 1 |

† Default after reset (PUC/POR)

- NOTES: 1. N/A: Not available or not applicable
 2. X: Don't care
 3. Function controlled by JTAG.



Port P1 pin schematic: P1.7, input/output with Schmitt trigger and in-system access features

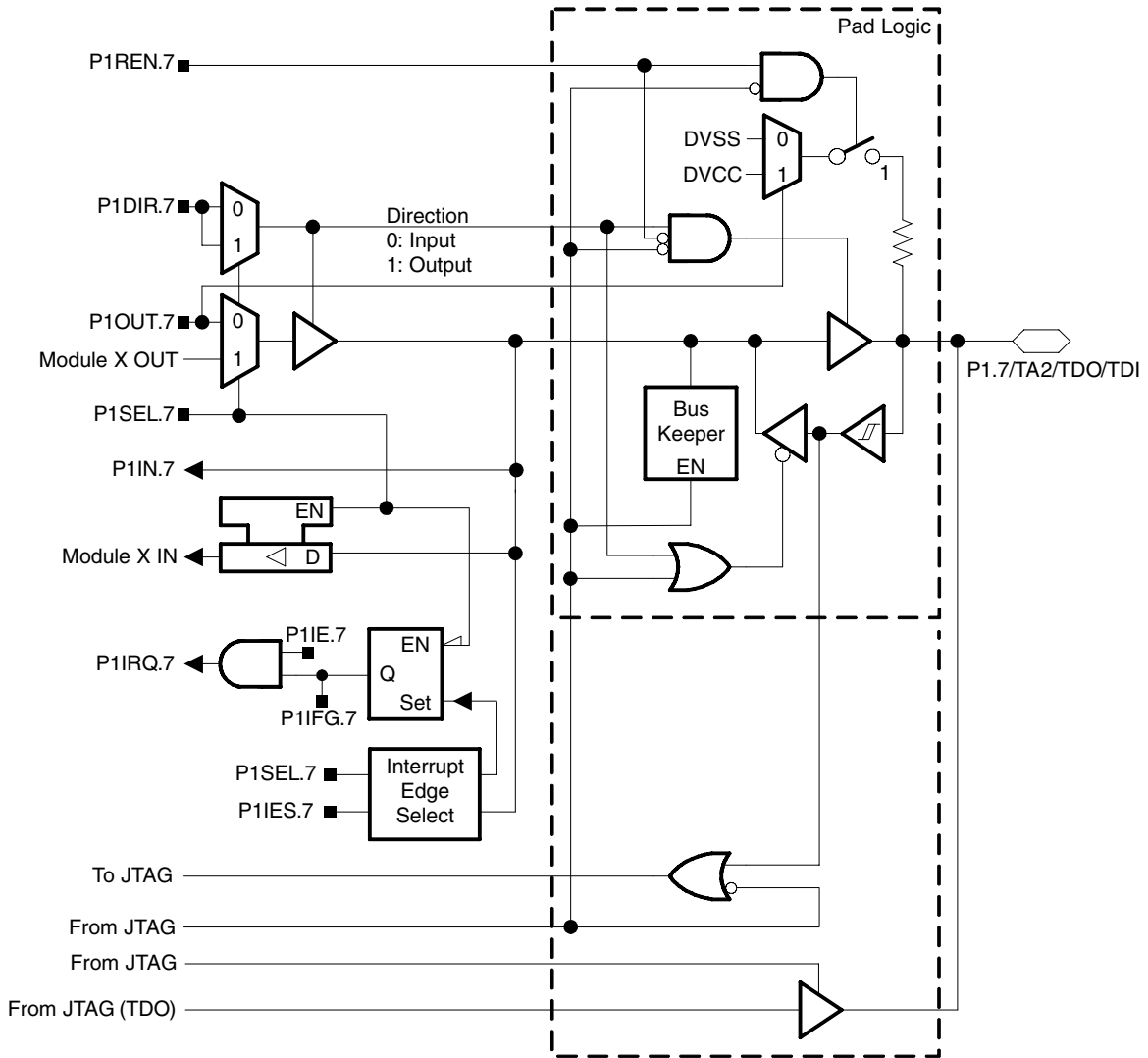

Port P1 (P1.7) pin functions

| PIN NAME (P1.X) | X | FUNCTION | CONTROL BITS / SIGNALS | | |
|-------------------|---|----------------------|------------------------|---------|-------------|
| | | | P1DIR.x | P1SEL.x | 4-Wire JTAG |
| P1.7†/TA2/TDO/TDI | 7 | P1.7† (I/O) | I: 0; O: 1 | 0 | 0 |
| | | Timer_A3.TA2 | 1 | 1 | 0 |
| | | TDO/TDI (see Note 3) | X | X | 1 |

† Default after reset (PUC/POR)

- NOTES: 1. N/A: Not available or not applicable
 2. X: Don't care
 3. Function controlled by JTAG.

MSP430x22x2, MSP430x22x4 MIXED SIGNAL MICROCONTROLLER

SLAS504B – JULY 2006 – REVISED JULY 2007

Port P2 pin schematic: P2.0, P2.2, input/output with Schmitt trigger

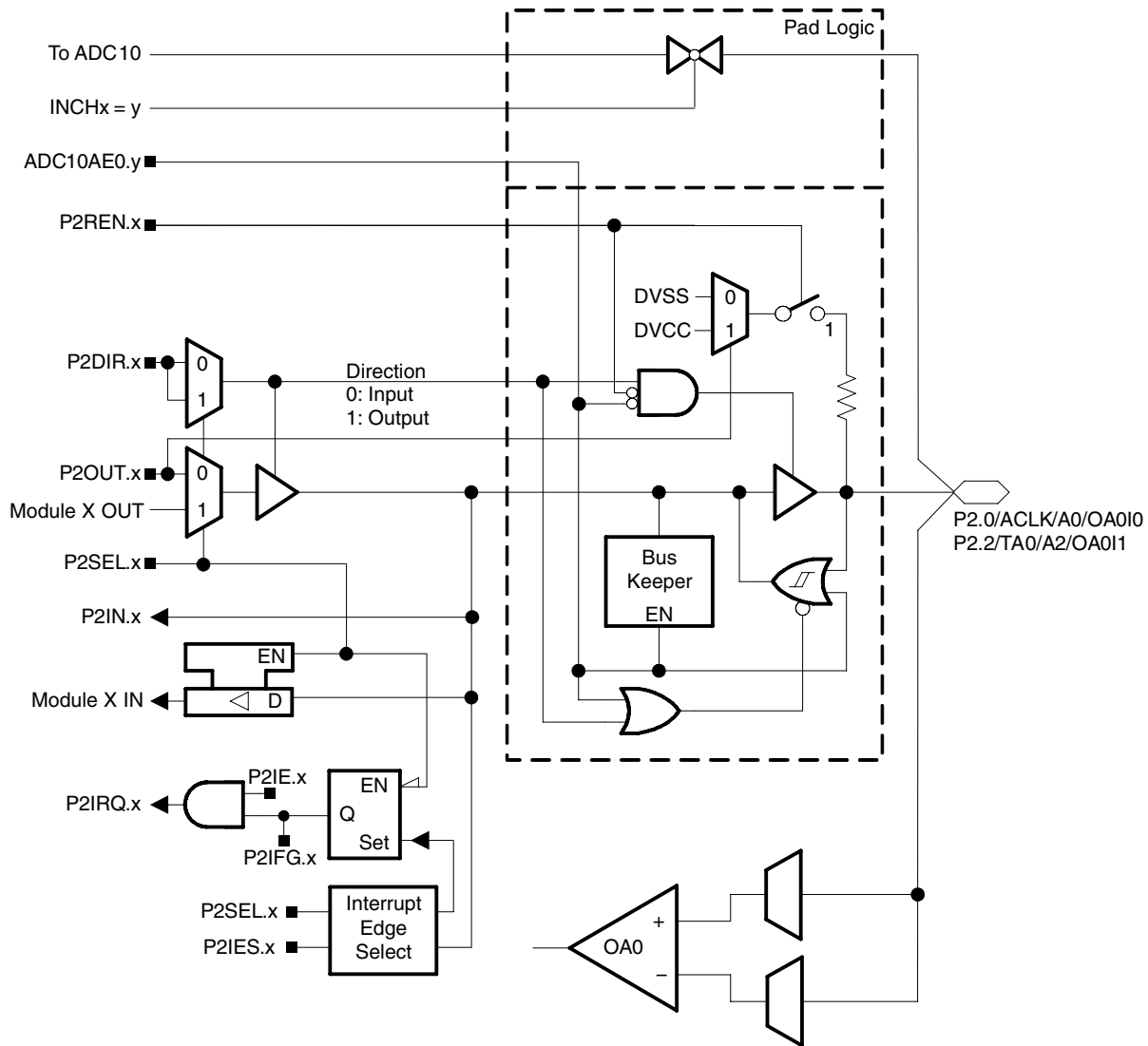

Port P2 (P2.0, P2.2) pin functions

| PIN NAME (P2.X) | X | Y | FUNCTION | CONTROL BITS / SIGNALS | | |
|--------------------|---|---|-----------------------|------------------------|---------|------------|
| | | | | P2DIR.x | P2SEL.x | ADC10AE0.y |
| P2.0/ACLK/A0/OA0I0 | 0 | 0 | P2.0† (I/O) | I: 0; O: 1 | 0 | 0 |
| | | | ACLK | 1 | 1 | 0 |
| | | | A0/OA0I0 (see Note 3) | X | X | 1 |
| P2.2/TA0/A2/OA0I1 | 2 | 2 | P2.2† (I/O) | I: 0; O: 1 | 0 | 0 |
| | | | Timer_A3.CCI0B | 0 | 1 | 0 |
| | | | Timer_A3.TA0 | 1 | 1 | 0 |
| | | | A2/OA0I1 (see Note 3) | X | X | 1 |

† Default after reset (PUC/POR)

NOTES: 1. N/A: Not available or not applicable

2. X: Don't care

3. Setting the ADC10AE0.y bit disables the output driver as well as the input schmitt trigger to prevent parasitic cross currents when applying analog signals.



POST OFFICE BOX 655303 • DALLAS, TEXAS 75265
POST OFFICE BOX 1443 • HOUSTON, TEXAS 77251-1443

Port P2 pin schematic: P2.1, input/output with Schmitt trigger

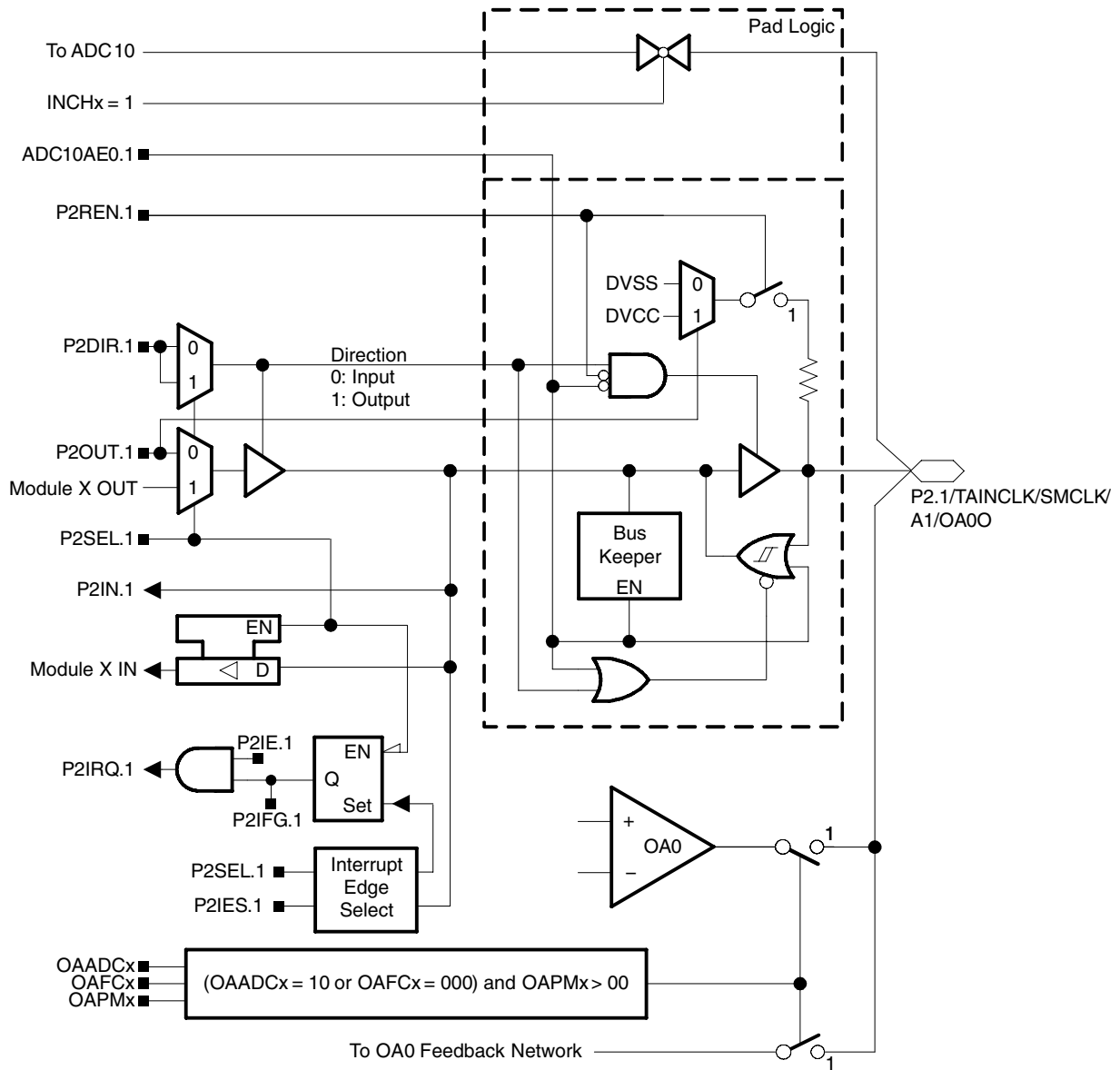

MSP430x22x2, MSP430x22x4 MIXED SIGNAL MICROCONTROLLER

SLAS504B – JULY 2006 – REVISED JULY 2007

Port P2 pin schematic: P2.3, input/output with Schmitt trigger

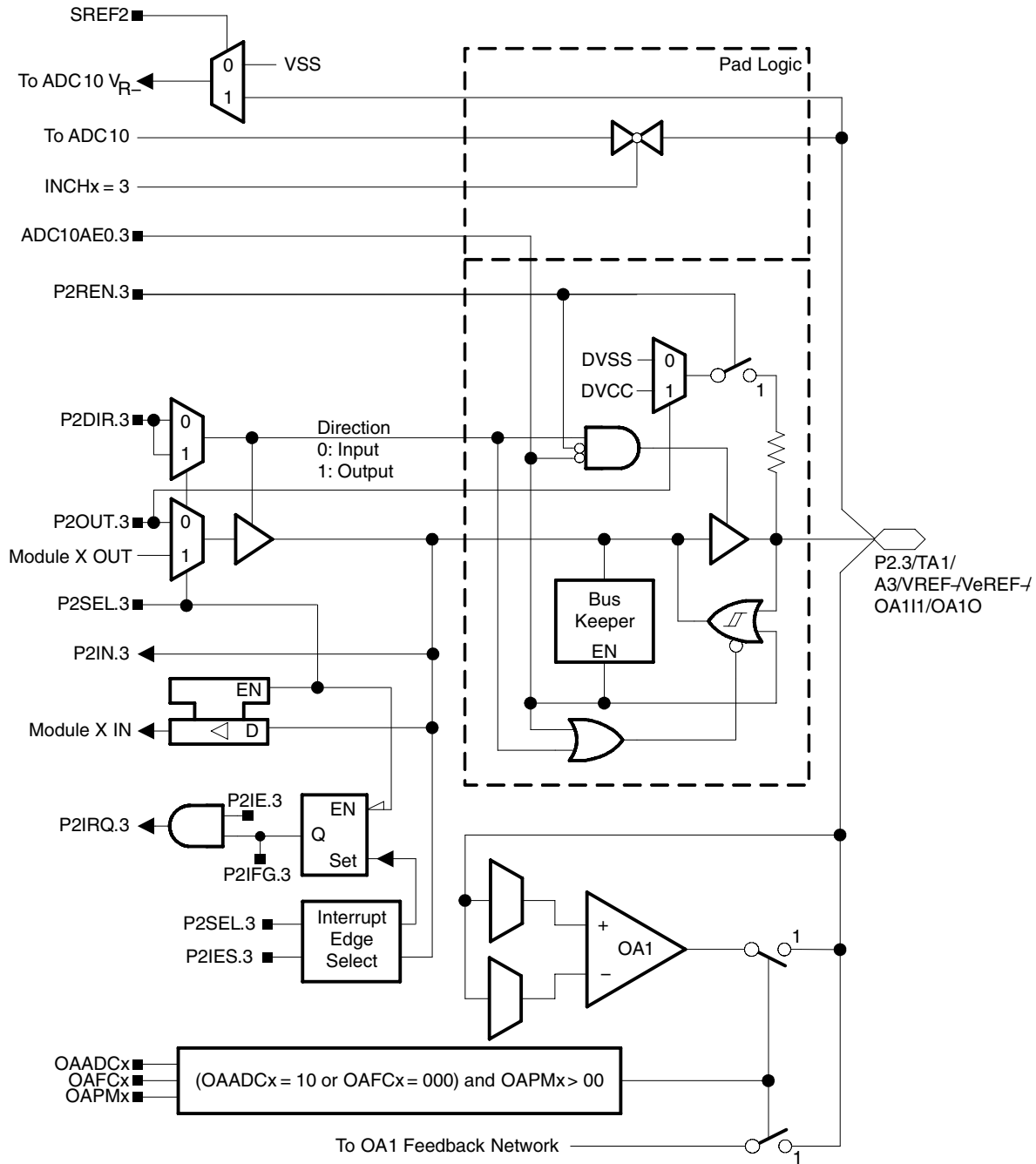

Port P2 (P2.1) pin functions

| PIN NAME (P2.X) | X | Y | FUNCTION | CONTROL BITS / SIGNALS | | |
|--------------------------------|---|---|----------------------|------------------------|---------|------------|
| | | | | P2DIR.x | P2SEL.x | ADC10AE0.y |
| P2.1/TAINCLK/SMCLK /A1/OA00 | 1 | 1 | P2.1† (I/O) | I: 0; O: 1 | 0 | 0 |
| | | | Timer_A3.INCLK | 0 | 1 | 0 |
| | | | SMCLK | 1 | 1 | 0 |
| | | | A1/OA00 (see Note 3) | X | X | 1 |

† Default after reset (PUC/POR)

- NOTES:
1. N/A: Not available or not applicable
 2. X: Don't care
 3. Setting the ADC10AE0.y bit disables the output driver as well as the input schmitt trigger to prevent parasitic cross currents when applying analog signals.

Port P2 (P2.3) pin functions

| PIN NAME (P2.X) | X | Y | FUNCTION | CONTROL BITS / SIGNALS | | |
|---|---|---|---|------------------------|---------|------------|
| | | | | P2DIR.x | P2SEL.x | ADC10AE0.y |
| P2.3/TA1/ A3/V _{REF-} /V _{eREF-} / OA111/OA10 | 3 | 3 | P2.3† (I/O) | I: 0; O: 1 | 0 | 0 |
| | | | Timer_A3.CCI1B | 0 | 1 | 0 |
| | | | Timer_A3.TA1 | 1 | 1 | 0 |
| | | | A3/V _{REF-} /V _{eREF-} /OA111/OA10 (see Note 3) | X | X | 1 |

† Default after reset (PUC/POR)

- NOTES:
1. N/A: Not available or not applicable
 2. X: Don't care
 3. Setting the ADC10AE0.y bit disables the output driver as well as the input schmitt trigger to prevent parasitic cross currents when applying analog signals.

MSP430x22x2, MSP430x22x4 MIXED SIGNAL MICROCONTROLLER

SLAS504B – JULY 2006 – REVISED JULY 2007

Port P2 pin schematic: P2.4, input/output with Schmitt trigger

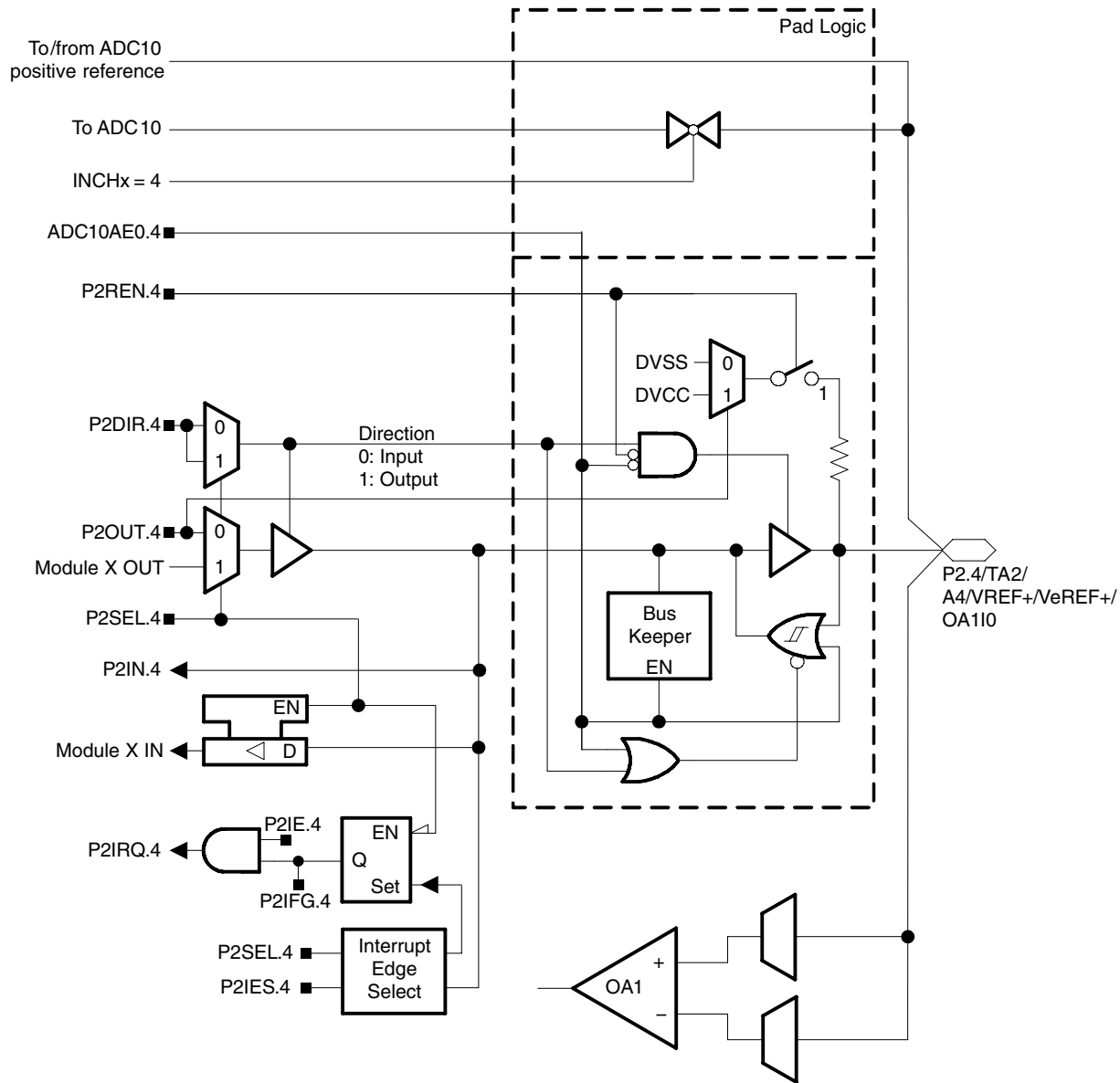

Port P2 (P2.4) pin functions

| PIN NAME (P2.X) | X | Y | FUNCTION | CONTROL BITS / SIGNALS | | |
|--|---|---|------------------------------------|------------------------|---------|------------|
| | | | | P2DIR.x | P2SEL.x | ADC10AE0.y |
| P2.4/TA2/ A4/VREF+/VeREF+/ OA110 | 4 | 4 | P2.4† (I/O) | I: 0; O: 1 | 0 | 0 |
| | | | Timer_A3.TA2 | 1 | 1 | 0 |
| | | | A4/VREF+/VeREF+/OA110 (see Note 3) | X | X | 1 |

† Default after reset (PUC/POR)

NOTES: 1. N/A: Not available or not applicable

2. X: Don't care

3. Setting the ADC10AE0.y bit disables the output driver as well as the input schmitt trigger to prevent parasitic cross currents when applying analog signals.

Port P2 pin schematic: P2.5, input/output with Schmitt trigger and external R_{OSC} for DCO

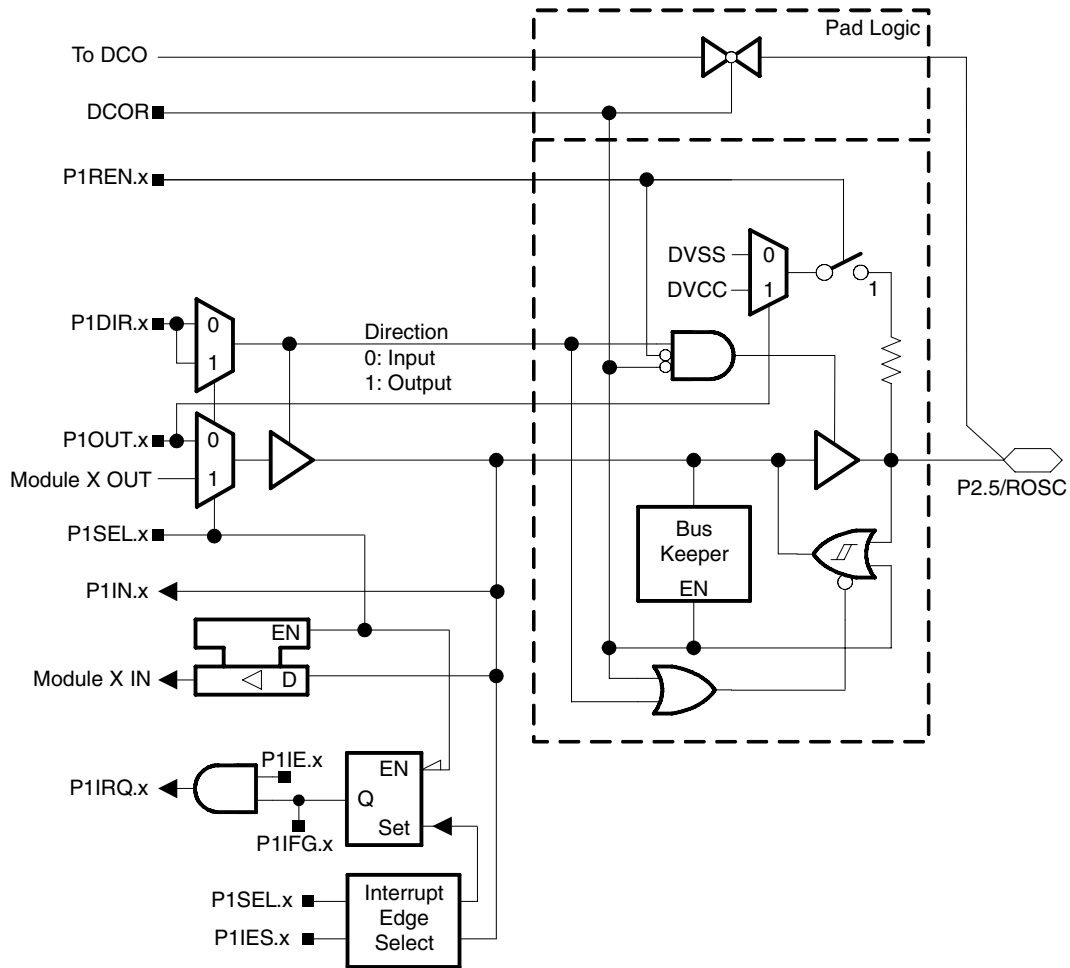

Port P2 (P2.5) pin functions

| PIN NAME (P2.X) | X | FUNCTION | CONTROL BITS / SIGNALS | | |
|-----------------------|---|------------------|------------------------|---------|------|
| | | | P2DIR.x | P2SEL.x | DCOR |
| P2.5/R _{osc} | 5 | P2.5† (I/O) | I: 0; O: 1 | 0 | 0 |
| | | N/A | 0 | 1 | 0 |
| | | DV _{SS} | 1 | 1 | 0 |
| | | R _{osc} | X | X | 1 |

† Default after reset (PUC/POR)

NOTES: 1. N/A: Not available or not applicable

2. X: Don't care

3. Setting the ADC10AE0.y bit disables the output driver as well as the input Schmitt trigger to prevent parasitic cross currents when applying analog signals.

MSP430x22x2, MSP430x22x4 MIXED SIGNAL MICROCONTROLLER

SLAS504B – JULY 2006 – REVISED JULY 2007

Port P2 pin schematic: P2.6, input/output with Schmitt trigger and crystal oscillator input

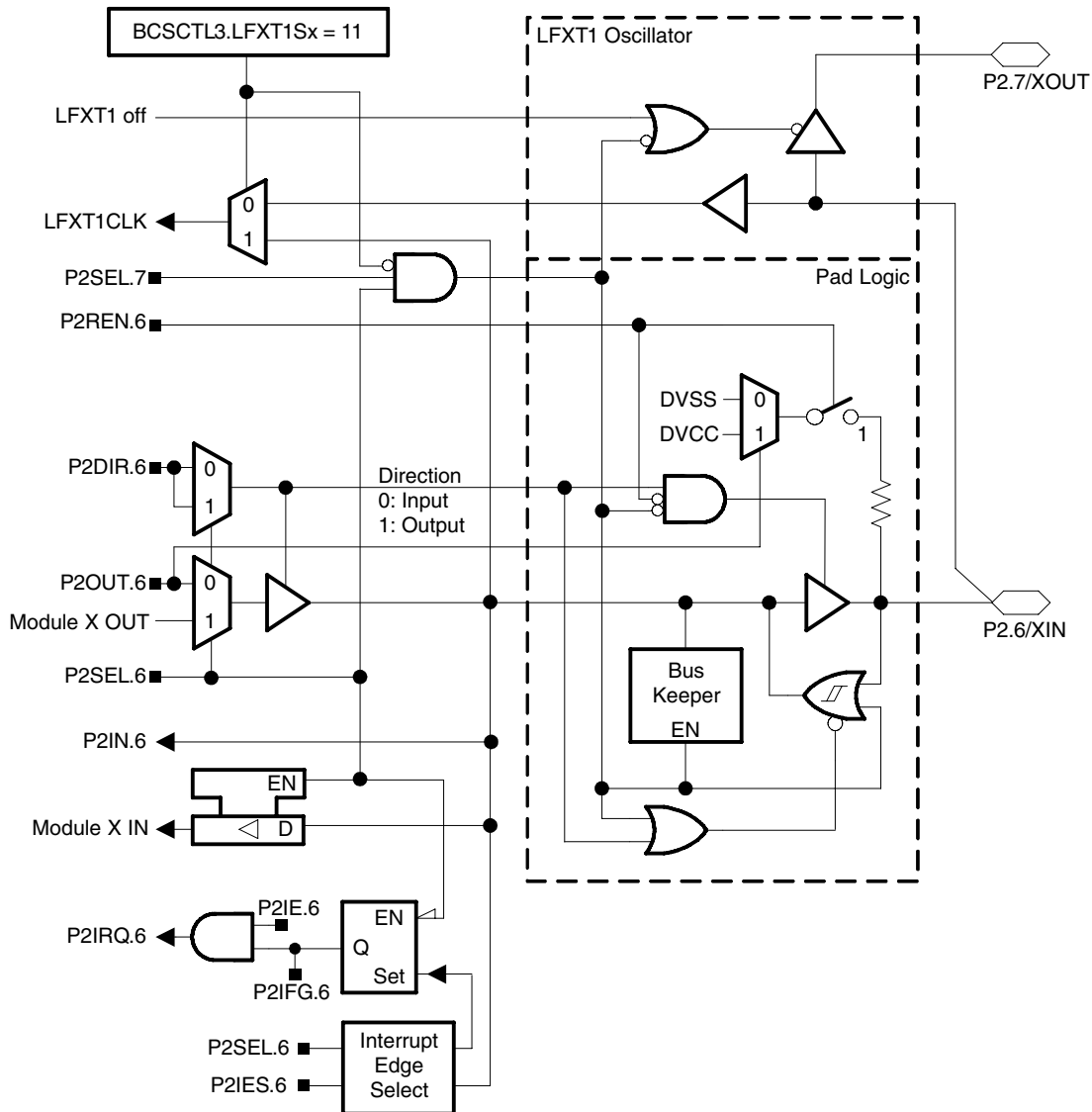

Port P2 (P2.6) pin functions

| PIN NAME (P2.X) | X | FUNCTION | CONTROL BITS / SIGNALS | |
|-----------------|---|------------|------------------------|---------|
| | | | P2DIR.x | P2SEL.x |
| P2.6/XIN | 6 | P2.6 (I/O) | I: 0; O: 1 | 0 |
| | | XIN† | X | 1 |

† Default after reset (PUC/POR)

NOTES: 1. N/A: Not available or not applicable
2. X: Don't care

Port P2 pin schematic: P2.7, input/output with Schmitt trigger and crystal oscillator output

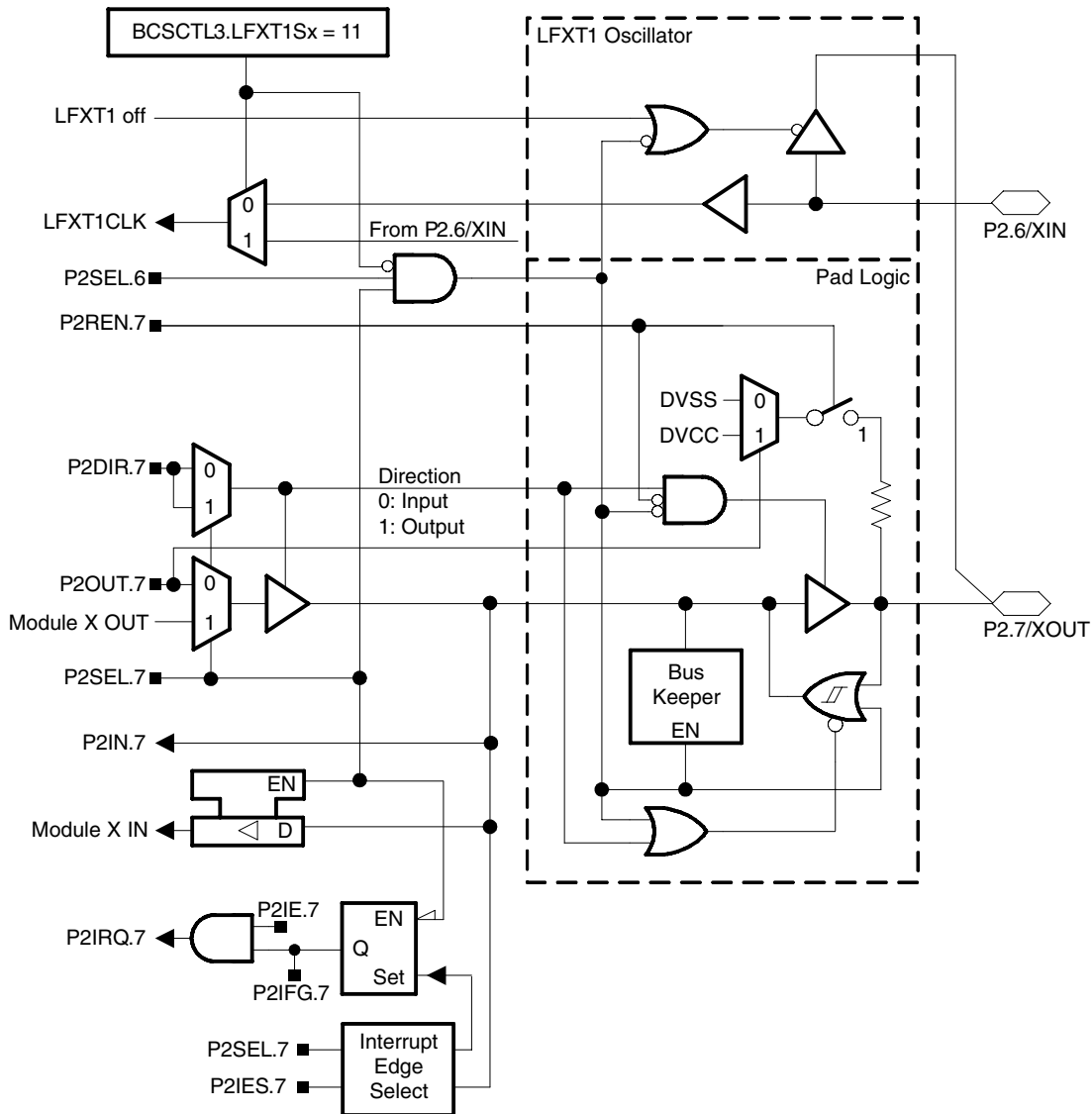

Port P2 (P2.7) pin functions

| PIN NAME (P2.X) | X | FUNCTION | CONTROL BITS / SIGNALS | |
|-----------------|---|--------------------|------------------------|---------|
| | | | P2DIR.x | P2SEL.x |
| XOUT/P2.7 | 6 | P2.7 (I/O) | I: 0; O: 1 | 0 |
| | | XOUT† (see Note 3) | X | 1 |

† Default after reset (PUC/POR)

NOTES: 1. N/A: Not available or not applicable

2. X: Don't care

3. If the pin XOUT/P2.7 is used as an input a current can flow until P2SEL.7 is cleared due to the oscillator output driver connection to this pin after reset.

MSP430x22x2, MSP430x22x4 MIXED SIGNAL MICROCONTROLLER

SLAS504B – JULY 2006 – REVISED JULY 2007

Port P3 pin schematic: P3.0, input/output with Schmitt trigger

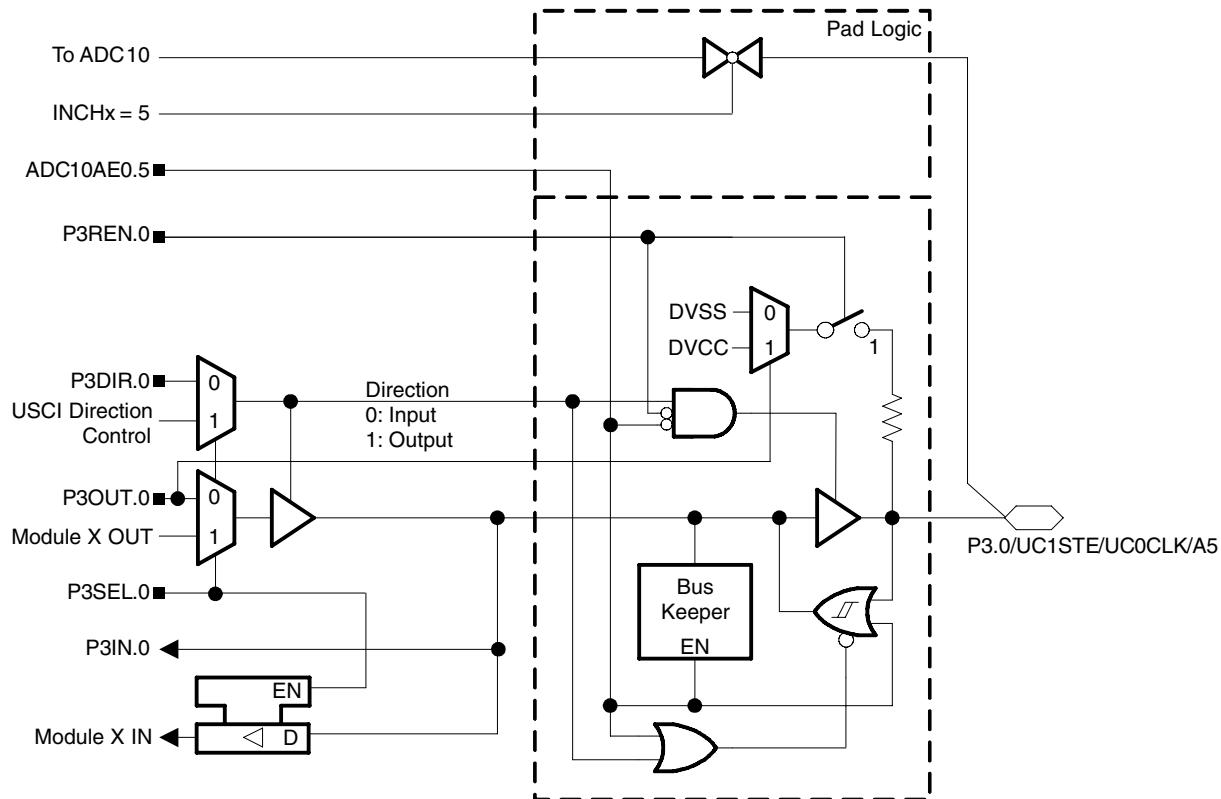

Port P3 (P3.0) pin functions

| PIN NAME (P3.X) | X | Y | FUNCTION | CONTROL BITS / SIGNALS | | |
|---------------------------|---|---|--------------------------------|------------------------|---------|------------|
| | | | | P3DIR.x | P3SEL.x | ADC10AE0.y |
| P3.0/ UC1STE/UC0CLK/A5 | 0 | 5 | P3.0† (I/O) | I: 0; O: 1 | 0 | 0 |
| | | | UC1STE/UC0CLK (see Notes 3, 4) | X | 1 | 0 |
| | | | A5 (see Note 5) | X | X | 1 |

† Default after reset (PUC/POR)

NOTES: 1. N/A: Not available or not applicable

2. X: Don't care

3. The pin direction is controlled by the USCI module.

4. UC0CLK function takes precedence over UC1STE function. If the pin is required as UC0CLK input or output USCI1 will be forced to 3-wire SPI mode if 4-wire SPI mode is selected.

5. Setting the ADC10AE0.y bit disables the output driver as well as the input schmitt trigger to prevent parasitic cross currents when applying analog signals.



Port P3 pin schematic: P3.1 to P3.5, input/output with Schmitt trigger

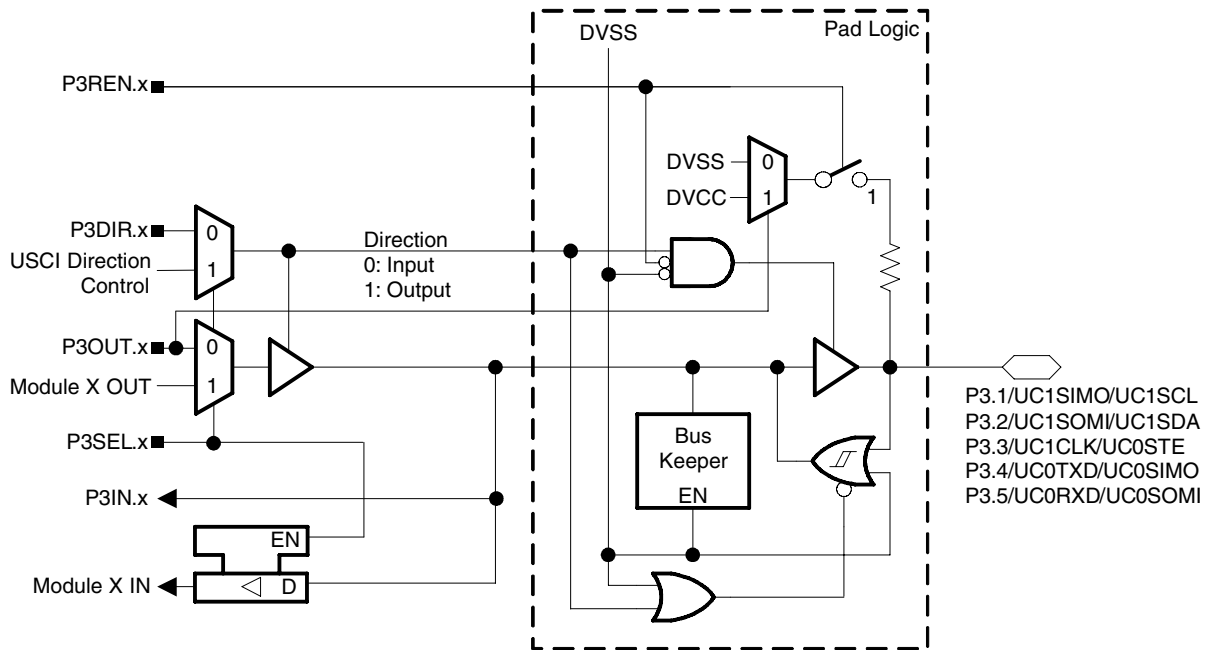

Port P3 (P3.1 to P3.5) pin functions

| PIN NAME (P3.X) | X | FUNCTION | CONTROL BITS / SIGNALS | |
|-------------------------|---|--------------------------------|------------------------|---------|
| | | | P3DIR.x | P3SEL.x |
| P3.1/ UC1SIMO/UC1SDA | 1 | P3.1† (I/O) | I: 0; O: 1 | 0 |
| | | UC1SIMO/UC1SDA (see Note 3) | X | 1 |
| P3.2/ UC1SOMI/UC1SCL | 1 | P3.2† (I/O) | I: 0; O: 1 | 0 |
| | | UC1SOMI/UC1SCL (see Note 3) | X | 1 |
| P3.3/ UC1CLK/UC0STE | 1 | P3.3† (I/O) | I: 0; O: 1 | 0 |
| | | UC1CLK/UC0STE (see Notes 3, 4) | X | 1 |
| P3.4/ UC0TXD/UC0SIMO | 1 | P3.4† (I/O) | I: 0; O: 1 | 0 |
| | | UC0TXD/UC0SIMO (see Note 3) | X | 1 |
| P3.5/ UC0RXD/UC0SOMI | 1 | P3.5† (I/O) | I: 0; O: 1 | 0 |
| | | UC0RXD/UC0SOMI (see Note 3) | X | 1 |

† Default after reset (PUC/POR)

- NOTES:
1. N/A: Not available or not applicable
 2. X: Don't care
 3. The pin direction is controlled by the USCI module.
 4. UC1CLK function takes precedence over UC0STE function. If the pin is required as UC1CLK input or output USCI0 will be forced to 3-wire SPI mode even if 4-wire SPI mode is selected.

MSP430x22x2, MSP430x22x4 MIXED SIGNAL MICROCONTROLLER

SLAS504B – JULY 2006 – REVISED JULY 2007

Port P3 pin schematic: P3.6 to P3.7, input/output with Schmitt trigger

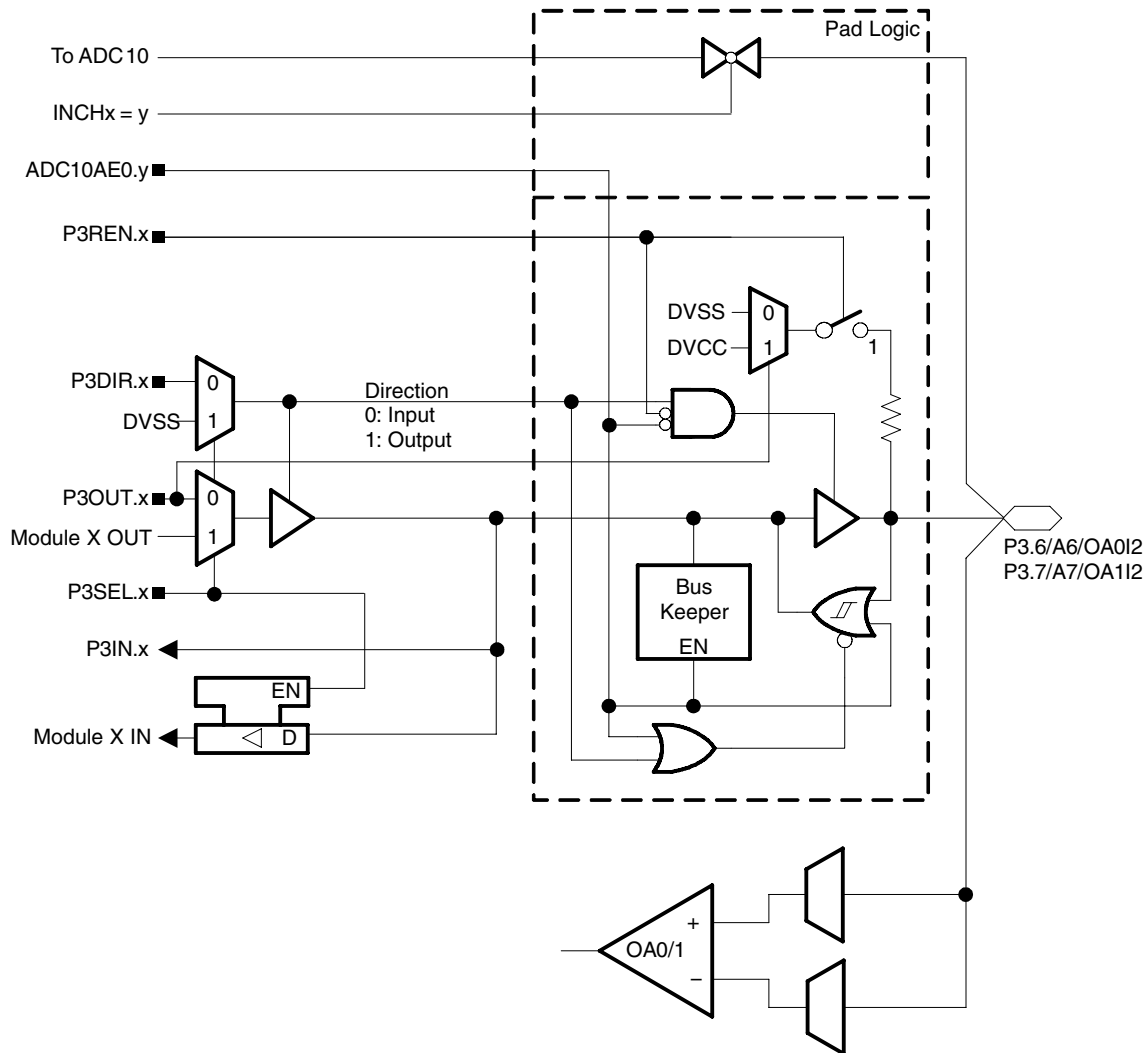

Port P3 (P3.6, P3.7) pin functions

| PIN NAME (P3.X) | X | Y | FUNCTION | CONTROL BITS / SIGNALS | | |
|-----------------|---|---|-----------------------|------------------------|---------|------------|
| | | | | P3DIR.x | P3SEL.x | ADC10AE0.y |
| P3.6/A6/OA0I2 | 6 | 6 | P3.6† (I/O) | I: 0; O: 1 | 0 | 0 |
| | | | A6/OA0I2 (see Note 5) | X | X | 1 |
| P3.7/A7/OA1I2 | 7 | 7 | P3.7† (I/O) | I: 0; O: 1 | 0 | 0 |
| | | | A7/OA1I2 (see Note 5) | X | X | 1 |

† Default after reset (PUC/POR)

NOTES: 1. N/A: Not available or not applicable

2. X: Don't care

3. The pin direction is controlled by the USCI module.

4. UC1CLK function takes precedence over UC0STE function. If the pin is required as UC1CLK input or output USCI0 will be forced to 3-wire SPI mode if 4-wire SPI mode is selected.

5. Setting the ADC10AE0.y bit disables the output driver as well as the input schmitt trigger to prevent parasitic cross currents when applying analog signals.

Port P4 pin schematic: P4.0 to P4.2, input/output with Schmitt trigger

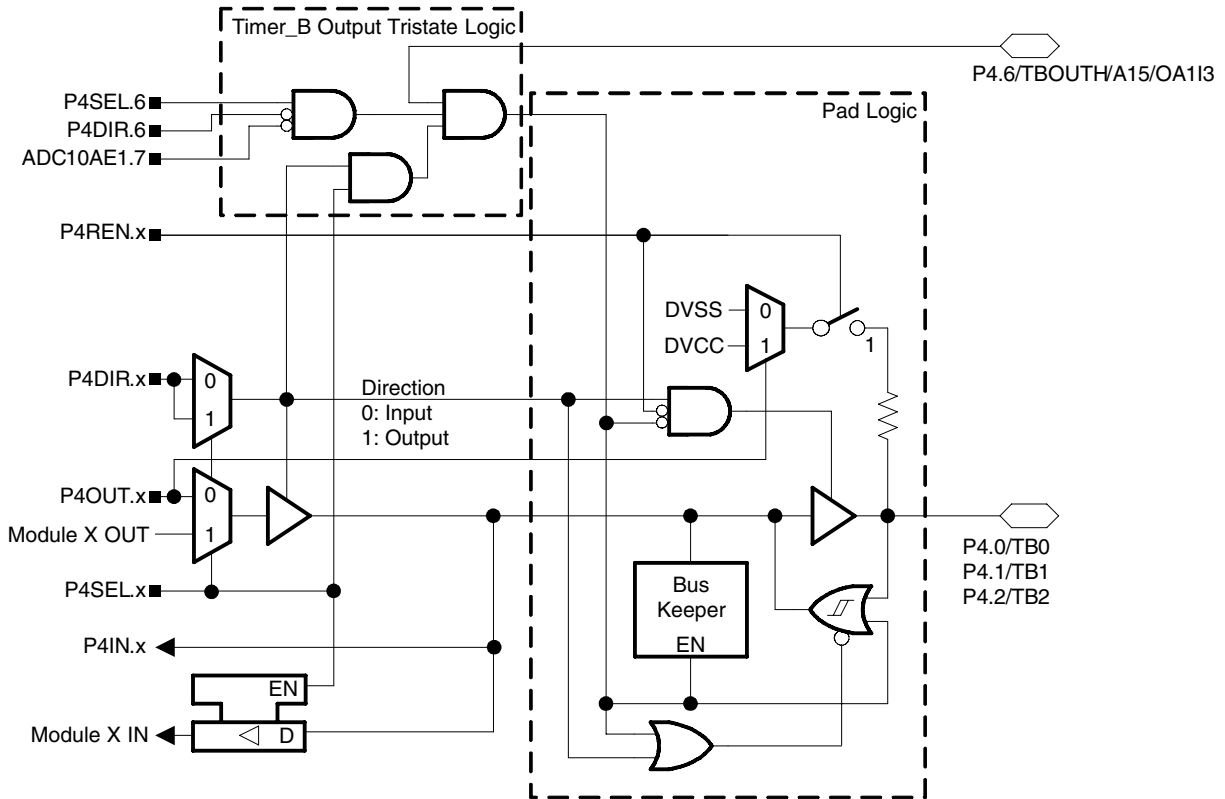

Port P4 (P4.0 to P4.2) pin functions

| PIN NAME (P4.X) | X | FUNCTION | CONTROL BITS / SIGNALS | |
|-----------------|---|----------------|------------------------|---------|
| | | | P4DIR.x | P4SEL.x |
| P4.0/TB0 | 0 | P4.0† (I/O) | I: 0; O: 1 | 0 |
| | | Timer_B3.CCI0A | 0 | 1 |
| | | Timer_B3.TB0 | 1 | 1 |
| P4.1/TB1 | 1 | P4.1† (I/O) | I: 0; O: 1 | 0 |
| | | Timer_B3.CCI1A | 0 | 1 |
| | | Timer_B3.TB1 | 1 | 1 |
| P4.2/TB2 | 2 | P4.2† (I/O) | I: 0; O: 1 | 0 |
| | | Timer_B3.CCI2A | 0 | 1 |
| | | Timer_B3.TB2 | 1 | 1 |

† Default after reset (PUC/POR)

NOTES: 1. N/A: Not available or not applicable
2. X: Don't care

MSP430x22x2, MSP430x22x4 MIXED SIGNAL MICROCONTROLLER

SLAS504B – JULY 2006 – REVISED JULY 2007

Port P4 pin schematic: P4.3 to P4.4, input/output with Schmitt trigger

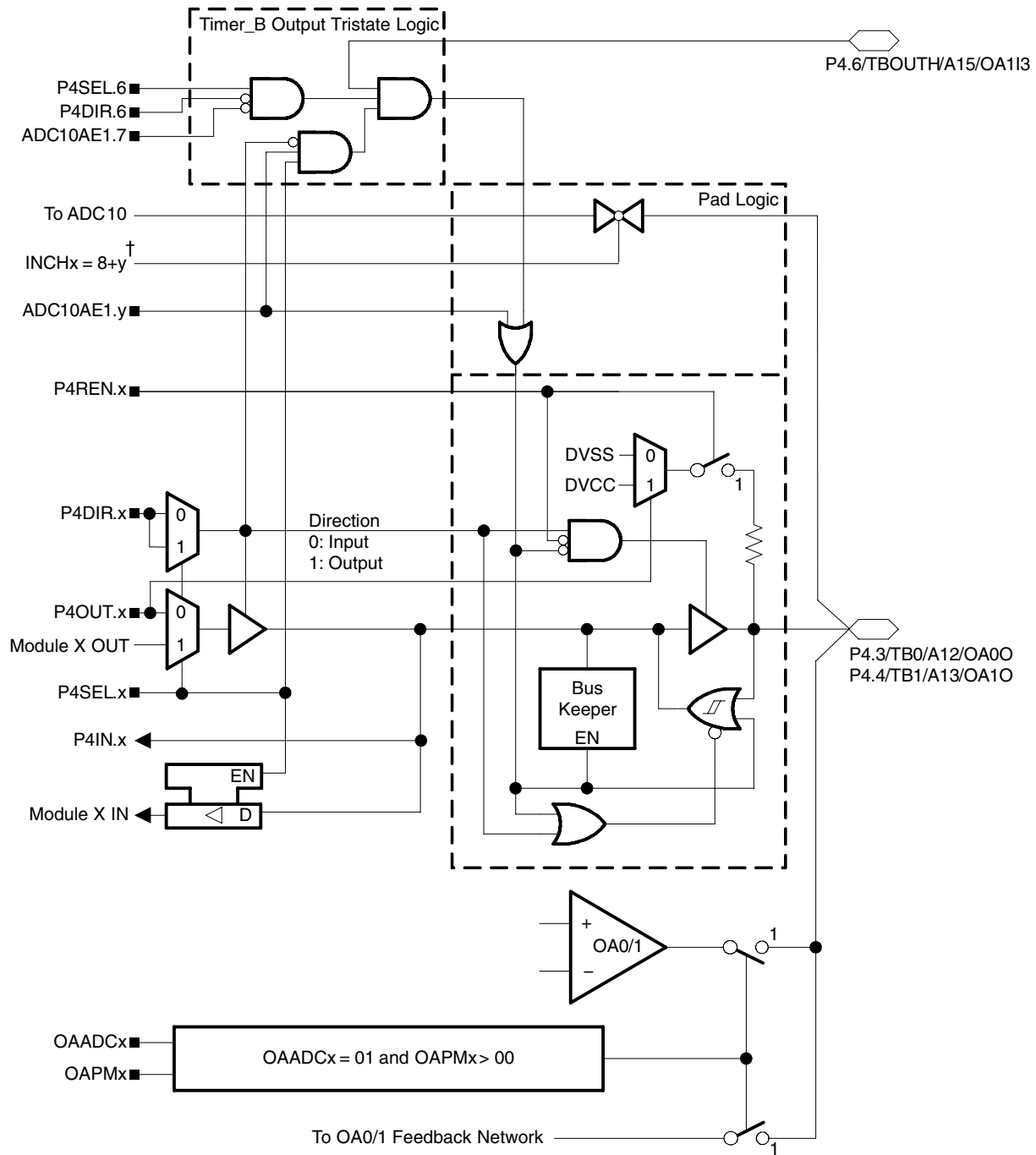

† If OAADCx = 11 and not OAFcx = 000 the ADC input A12 or A13 is internally connected to the OA0 or OA1 output respectively and the connections from the ADC and the operational amplifiers to the pad are disabled.

Port P4 (P4.3 to P4.4) pin functions

| PIN NAME (P4.X) | X | Y | FUNCTION | CONTROL BITS / SIGNALS | | |
|-------------------|---|---|-----------------------|------------------------|---------|------------|
| | | | | P4DIR.x | P4SEL.x | ADC10AE1.y |
| P4.3/TB0/A12/OA00 | 3 | 4 | P4.3† (I/O) | I: 0; O: 1 | 0 | 0 |
| | | | Timer_B3.CCI0B | 0 | 1 | 0 |
| | | | Timer_B3.TB0 | 1 | 1 | 0 |
| | | | A12/OA00 (see Note 3) | X | X | 1 |
| P4.4/TB1/A13/OA10 | 4 | 5 | P4.4† (I/O) | I: 0; O: 1 | 0 | 0 |
| | | | Timer_B3.CCI1B | 0 | 1 | 0 |
| | | | Timer_B3.TB1 | 1 | 1 | 0 |
| | | | A13/OA10 (see Note 3) | X | X | 1 |

† Default after reset (PUC/POR)

- NOTES:
1. N/A: Not available or not applicable
 2. X: Don't care
 3. Setting the ADC10AE1.y bit disables the output driver as well as the input schmitt trigger to prevent parasitic cross currents when applying analog signals.

MSP430x22x2, MSP430x22x4 MIXED SIGNAL MICROCONTROLLER

SLAS504B – JULY 2006 – REVISED JULY 2007

Port P4 pin schematic: P4.5, input/output with Schmitt trigger

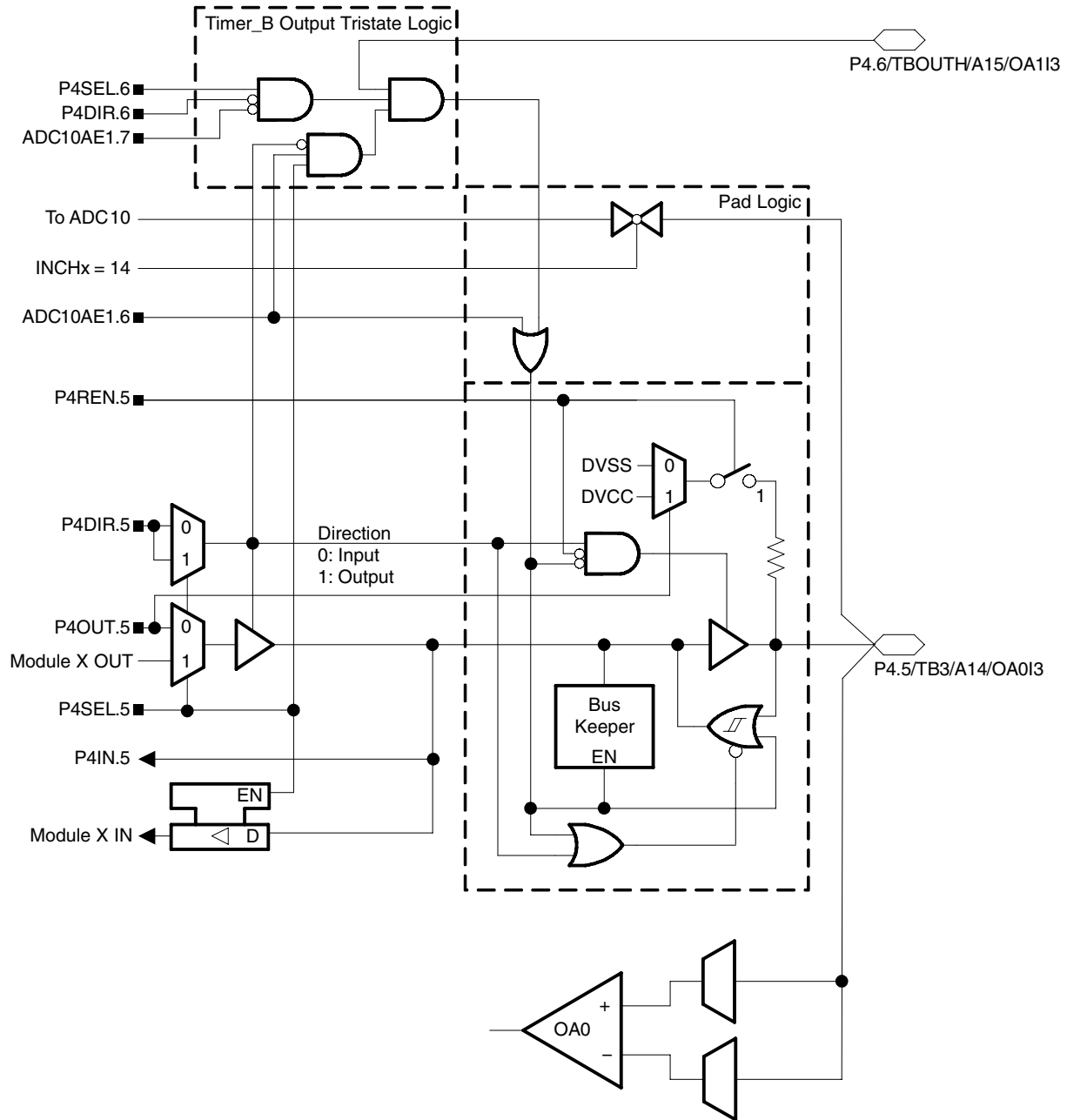

MSP430x22x2, MSP430x22x4 MIXED SIGNAL MICROCONTROLLER

SLAS504B – JULY 2006 – REVISED JULY 2007

Port P4 (P4.5) pin functions

| PIN NAME (P4.X) | X | Y | FUNCTION | CONTROL BITS / SIGNALS | | |
|--------------------|---|---|------------------------|------------------------|---------|------------|
| | | | | P4DIR.x | P4SEL.x | ADC10AE1.y |
| P4.5/TB3/A14/OA0I3 | 5 | 6 | P4.5† (I/O) | I: 0; O: 1 | 0 | 0 |
| | | | Timer_B3.TB2 | 1 | 1 | 0 |
| | | | A14/OA0I3 (see Note 3) | X | X | 1 |

† Default after reset (PUC/POR)

NOTES: 1. N/A: Not available or not applicable

2. X: Don't care

3. Setting the ADC10AE1.y bit disables the output driver as well as the input schmitt trigger to prevent parasitic cross currents when applying analog signals.



Port P4 pin schematic: P4.7, input/output with Schmitt trigger

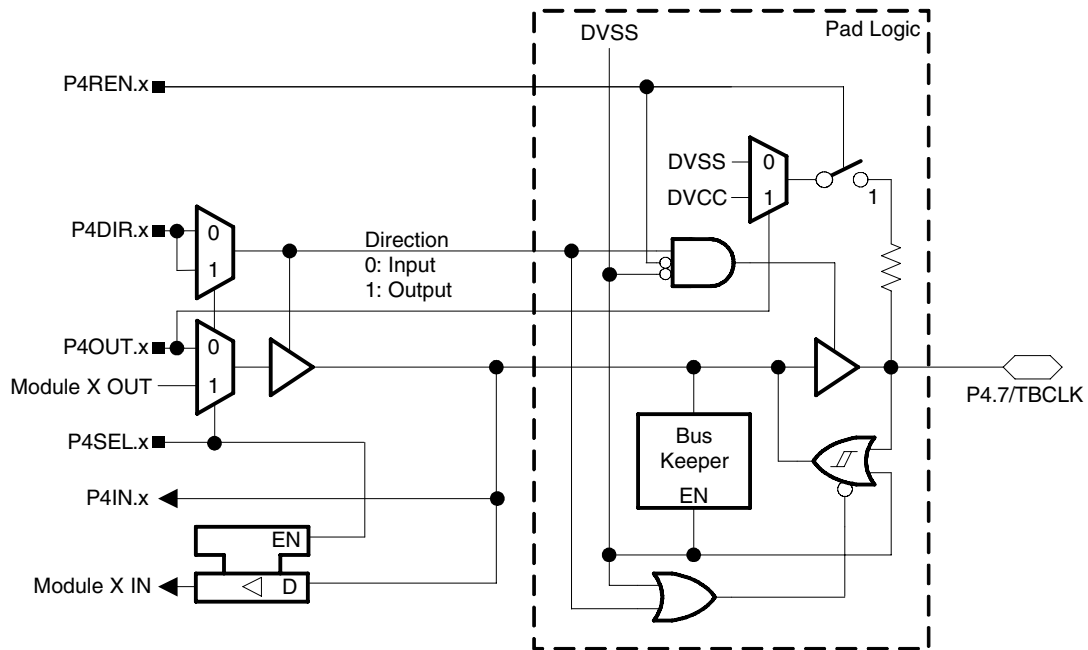

Port P4 (P4.7) pin functions

| PIN NAME (P4.X) | X | FUNCTION | CONTROL BITS / SIGNALS | |
|-----------------|---|------------------|------------------------|---------|
| | | | P4DIR.x | P4SEL.x |
| P4.7/TBCLK | 7 | P4.7† (I/O) | I: 0; O: 1 | 0 |
| | | Timer_B3.TBCLK | 0 | 1 |
| | | DV _{SS} | 1 | 1 |

† Default after reset (PUC/POR)

NOTES: 1. N/A: Not available or not applicable
2. X: Don't care

MSP430x22x2, MSP430x22x4 MIXED SIGNAL MICROCONTROLLER

SLAS504B – JULY 2006 – REVISED JULY 2007

JTAG fuse check mode

MSP430 devices that have the fuse on the TEST terminal have a fuse check mode that tests the continuity of the fuse the first time the JTAG port is accessed after a power-on reset (POR). When activated, a fuse check current, I_{TF} , of 1 mA at 3 V, 2.5 mA at 5 V can flow from the TEST pin to ground if the fuse is not burned. Care must be taken to avoid accidentally activating the fuse check mode and increasing overall system power consumption.

When the TEST pin is again taken low after a test or programming session, the fuse check mode and sense currents are terminated.

Activation of the fuse check mode occurs with the first negative edge on the TMS pin after power up or if TMS is being held low during power up. The second positive edge on the TMS pin deactivates the fuse check mode. After deactivation, the fuse check mode remains inactive until another POR occurs. After each POR the fuse check mode has the potential to be activated.

The fuse check current only flows when the fuse check mode is active and the TMS pin is in a low state (see Figure 28). Therefore, the additional current flow can be prevented by holding the TMS pin high (default condition).

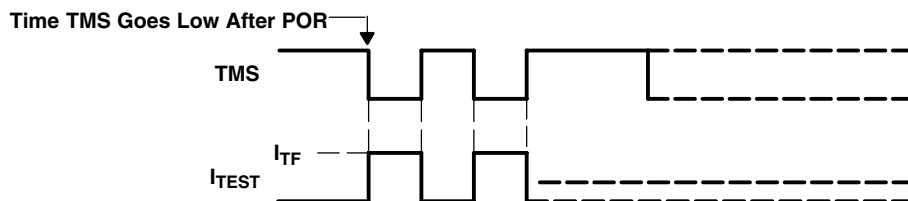

Figure 28. Fuse Check Mode Current, MSP430F22xx

NOTE:

The CODE and RAM data protection is ensured if the JTAG fuse is blown and the 256-bit bootloader access key is used. Also, see the *bootstrap loader* section for more information.

Data Sheet Revision History

| Literature Number | Summary |
|--------------------------|--|
| SLAS504 | Preliminary data sheet release. |
| SLAS504A | Production data sheet release. Updated specification and added characterization graphs. Updated/corrected port pin schematics. |
| SLAS504B | Maximum low-power mode supply current limits decreased. Added note concerning f_{UCxCLK} to USCI SPI parameters. |

NOTE: The referring page and figure numbers are referred to the respective document revision.

PACKAGING INFORMATION

| Orderable Device | Status ⁽¹⁾ | Package Type | Package Drawing | Pins | Package Qty | Eco Plan ⁽²⁾ | Lead/Ball Finish | MSL Peak Temp ⁽³⁾ |
|------------------|-----------------------|--------------|-----------------|------|-------------|-------------------------|------------------|------------------------------|
| MSP430F2232IDA | ACTIVE | TSSOP | DA | 38 | 40 | Green (RoHS & no Sb/Br) | CU NIPDAU | Level-2-260C-1 YEAR |
| MSP430F2232IDAR | ACTIVE | TSSOP | DA | 38 | 2000 | Green (RoHS & no Sb/Br) | CU NIPDAU | Level-2-260C-1 YEAR |
| MSP430F2232IRHAR | ACTIVE | QFN | RHA | 40 | 2500 | Green (RoHS & no Sb/Br) | CU NIPDAU | Level-3-260C-168 HR |
| MSP430F2232IRHAT | ACTIVE | QFN | RHA | 40 | 250 | Green (RoHS & no Sb/Br) | CU NIPDAU | Level-3-260C-168 HR |
| MSP430F2232TDA | ACTIVE | TSSOP | DA | 38 | 40 | Green (RoHS & no Sb/Br) | CU NIPDAU | Level-2-260C-1 YEAR |
| MSP430F2232TDAR | ACTIVE | TSSOP | DA | 38 | 2000 | Green (RoHS & no Sb/Br) | CU NIPDAU | Level-2-260C-1 YEAR |
| MSP430F2232TRHAR | ACTIVE | QFN | RHA | 40 | 2500 | Green (RoHS & no Sb/Br) | CU NIPDAU | Level-3-260C-168 HR |
| MSP430F2232TRHAT | ACTIVE | QFN | RHA | 40 | 250 | Green (RoHS & no Sb/Br) | CU NIPDAU | Level-3-260C-168 HR |
| MSP430F2234IDA | ACTIVE | TSSOP | DA | 38 | 40 | Green (RoHS & no Sb/Br) | CU NIPDAU | Level-2-260C-1 YEAR |
| MSP430F2234IDAR | ACTIVE | TSSOP | DA | 38 | 2000 | Green (RoHS & no Sb/Br) | CU NIPDAU | Level-2-260C-1 YEAR |
| MSP430F2234IRHAR | ACTIVE | QFN | RHA | 40 | 2500 | Green (RoHS & no Sb/Br) | CU NIPDAU | Level-3-260C-168 HR |
| MSP430F2234IRHAT | ACTIVE | QFN | RHA | 40 | 250 | Green (RoHS & no Sb/Br) | CU NIPDAU | Level-3-260C-168 HR |
| MSP430F2234TDA | ACTIVE | TSSOP | DA | 38 | 40 | Green (RoHS & no Sb/Br) | CU NIPDAU | Level-2-260C-1 YEAR |
| MSP430F2234TDAR | ACTIVE | TSSOP | DA | 38 | 2000 | Green (RoHS & no Sb/Br) | CU NIPDAU | Level-2-260C-1 YEAR |
| MSP430F2234TRHAR | ACTIVE | QFN | RHA | 40 | 2500 | Green (RoHS & no Sb/Br) | CU NIPDAU | Level-3-260C-168 HR |
| MSP430F2234TRHAT | ACTIVE | QFN | RHA | 40 | 250 | Green (RoHS & no Sb/Br) | CU NIPDAU | Level-3-260C-168 HR |
| MSP430F2252IDA | ACTIVE | TSSOP | DA | 38 | 40 | Green (RoHS & no Sb/Br) | CU NIPDAU | Level-2-260C-1 YEAR |
| MSP430F2252IDAR | ACTIVE | TSSOP | DA | 38 | 2000 | Green (RoHS & no Sb/Br) | CU NIPDAU | Level-2-260C-1 YEAR |
| MSP430F2252IRHAR | ACTIVE | QFN | RHA | 40 | 2500 | Green (RoHS & no Sb/Br) | CU NIPDAU | Level-3-260C-168 HR |
| MSP430F2252IRHAT | ACTIVE | QFN | RHA | 40 | 250 | Green (RoHS & no Sb/Br) | CU NIPDAU | Level-3-260C-168 HR |
| MSP430F2252TDA | ACTIVE | TSSOP | DA | 38 | 40 | Green (RoHS & no Sb/Br) | CU NIPDAU | Level-2-260C-1 YEAR |
| MSP430F2252TDAR | ACTIVE | TSSOP | DA | 38 | 2000 | Green (RoHS & no Sb/Br) | CU NIPDAU | Level-2-260C-1 YEAR |
| MSP430F2252TRHAR | ACTIVE | QFN | RHA | 40 | 2500 | Green (RoHS & no Sb/Br) | CU NIPDAU | Level-3-260C-168 HR |
| MSP430F2252TRHAT | ACTIVE | QFN | RHA | 40 | 250 | Green (RoHS & no Sb/Br) | CU NIPDAU | Level-3-260C-168 HR |
| MSP430F2254IDA | ACTIVE | TSSOP | DA | 38 | 40 | Green (RoHS & no Sb/Br) | CU NIPDAU | Level-2-260C-1 YEAR |

| Orderable Device | Status ⁽¹⁾ | Package Type | Package Drawing | Pins | Package Qty | Eco Plan ⁽²⁾ | Lead/Ball Finish | MSL Peak Temp ⁽³⁾ |
|------------------|-----------------------|--------------|-----------------|------|-------------|-------------------------|------------------|------------------------------|
| MSP430F2254IDAR | ACTIVE | TSSOP | DA | 38 | 2000 | Green (RoHS & no Sb/Br) | CU NIPDAU | Level-2-260C-1 YEAR |
| MSP430F2254IRHAR | ACTIVE | QFN | RHA | 40 | 2500 | Green (RoHS & no Sb/Br) | CU NIPDAU | Level-3-260C-168 HR |
| MSP430F2254IRHAT | ACTIVE | QFN | RHA | 40 | 250 | Green (RoHS & no Sb/Br) | CU NIPDAU | Level-3-260C-168 HR |
| MSP430F2254TDA | ACTIVE | TSSOP | DA | 38 | 40 | Green (RoHS & no Sb/Br) | CU NIPDAU | Level-2-260C-1 YEAR |
| MSP430F2254TDAR | ACTIVE | TSSOP | DA | 38 | 2000 | Green (RoHS & no Sb/Br) | CU NIPDAU | Level-2-260C-1 YEAR |
| MSP430F2254TRHAR | ACTIVE | QFN | RHA | 40 | 2500 | Green (RoHS & no Sb/Br) | CU NIPDAU | Level-3-260C-168 HR |
| MSP430F2254TRHAT | ACTIVE | QFN | RHA | 40 | 250 | Green (RoHS & no Sb/Br) | CU NIPDAU | Level-3-260C-168 HR |
| MSP430F2272IDA | ACTIVE | TSSOP | DA | 38 | 40 | Green (RoHS & no Sb/Br) | CU NIPDAU | Level-2-260C-1 YEAR |
| MSP430F2272IDAR | ACTIVE | TSSOP | DA | 38 | 2000 | Green (RoHS & no Sb/Br) | CU NIPDAU | Level-2-260C-1 YEAR |
| MSP430F2272IRHAR | ACTIVE | QFN | RHA | 40 | 2500 | Green (RoHS & no Sb/Br) | CU NIPDAU | Level-3-260C-168 HR |
| MSP430F2272IRHAT | ACTIVE | QFN | RHA | 40 | 250 | Green (RoHS & no Sb/Br) | CU NIPDAU | Level-3-260C-168 HR |
| MSP430F2272TDA | ACTIVE | TSSOP | DA | 38 | 40 | Green (RoHS & no Sb/Br) | CU NIPDAU | Level-2-260C-1 YEAR |
| MSP430F2272TDAR | ACTIVE | TSSOP | DA | 38 | 2000 | Green (RoHS & no Sb/Br) | CU NIPDAU | Level-2-260C-1 YEAR |
| MSP430F2272TRHAR | ACTIVE | QFN | RHA | 40 | 2500 | Green (RoHS & no Sb/Br) | CU NIPDAU | Level-3-260C-168 HR |
| MSP430F2272TRHAT | ACTIVE | QFN | RHA | 40 | 250 | Green (RoHS & no Sb/Br) | CU NIPDAU | Level-3-260C-168 HR |
| MSP430F2274IDA | ACTIVE | TSSOP | DA | 38 | 40 | Green (RoHS & no Sb/Br) | CU NIPDAU | Level-2-260C-1 YEAR |
| MSP430F2274IDAR | ACTIVE | TSSOP | DA | 38 | 2000 | Green (RoHS & no Sb/Br) | CU NIPDAU | Level-2-260C-1 YEAR |
| MSP430F2274IRHAR | ACTIVE | QFN | RHA | 40 | 2500 | Green (RoHS & no Sb/Br) | CU NIPDAU | Level-3-260C-168 HR |
| MSP430F2274IRHAT | ACTIVE | QFN | RHA | 40 | 250 | Green (RoHS & no Sb/Br) | CU NIPDAU | Level-3-260C-168 HR |
| MSP430F2274TDA | ACTIVE | TSSOP | DA | 38 | 40 | Green (RoHS & no Sb/Br) | CU NIPDAU | Level-2-260C-1 YEAR |
| MSP430F2274TDAR | ACTIVE | TSSOP | DA | 38 | 2000 | Green (RoHS & no Sb/Br) | CU NIPDAU | Level-2-260C-1 YEAR |
| MSP430F2274TRHAR | ACTIVE | QFN | RHA | 40 | 2500 | Green (RoHS & no Sb/Br) | CU NIPDAU | Level-3-260C-168 HR |
| MSP430F2274TRHAT | ACTIVE | QFN | RHA | 40 | 250 | Green (RoHS & no Sb/Br) | CU NIPDAU | Level-3-260C-168 HR |

⁽¹⁾ The marketing status values are defined as follows:

ACTIVE: Product device recommended for new designs.

LIFEBUY: TI has announced that the device will be discontinued, and a lifetime-buy period is in effect.

NRND: Not recommended for new designs. Device is in production to support existing customers, but TI does not recommend using this part in a new design.

PREVIEW: Device has been announced but is not in production. Samples may or may not be available.

OBSOLETE: TI has discontinued the production of the device.

⁽²⁾ Eco Plan - The planned eco-friendly classification: Pb-Free (RoHS), Pb-Free (RoHS Exempt), or Green (RoHS & no Sb/Br) - please check <http://www.ti.com/productcontent> for the latest availability information and additional product content details.

TBD: The Pb-Free/Green conversion plan has not been defined.

Pb-Free (RoHS): TI's terms "Lead-Free" or "Pb-Free" mean semiconductor products that are compatible with the current RoHS requirements for all 6 substances, including the requirement that lead not exceed 0.1% by weight in homogeneous materials. Where designed to be soldered at high temperatures, TI Pb-Free products are suitable for use in specified lead-free processes.

Pb-Free (RoHS Exempt): This component has a RoHS exemption for either 1) lead-based flip-chip solder bumps used between the die and package, or 2) lead-based die adhesive used between the die and leadframe. The component is otherwise considered Pb-Free (RoHS compatible) as defined above.

Green (RoHS & no Sb/Br): TI defines "Green" to mean Pb-Free (RoHS compatible), and free of Bromine (Br) and Antimony (Sb) based flame retardants (Br or Sb do not exceed 0.1% by weight in homogeneous material)

⁽³⁾ MSL, Peak Temp. -- The Moisture Sensitivity Level rating according to the JEDEC industry standard classifications, and peak solder temperature.

Important Information and Disclaimer:The information provided on this page represents TI's knowledge and belief as of the date that it is provided. TI bases its knowledge and belief on information provided by third parties, and makes no representation or warranty as to the accuracy of such information. Efforts are underway to better integrate information from third parties. TI has taken and continues to take reasonable steps to provide representative and accurate information but may not have conducted destructive testing or chemical analysis on incoming materials and chemicals. TI and TI suppliers consider certain information to be proprietary, and thus CAS numbers and other limited information may not be available for release.

In no event shall TI's liability arising out of such information exceed the total purchase price of the TI part(s) at issue in this document sold by TI to Customer on an annual basis.

RHA (S-PQFP-N40)

PLASTIC QUAD FLATPACK

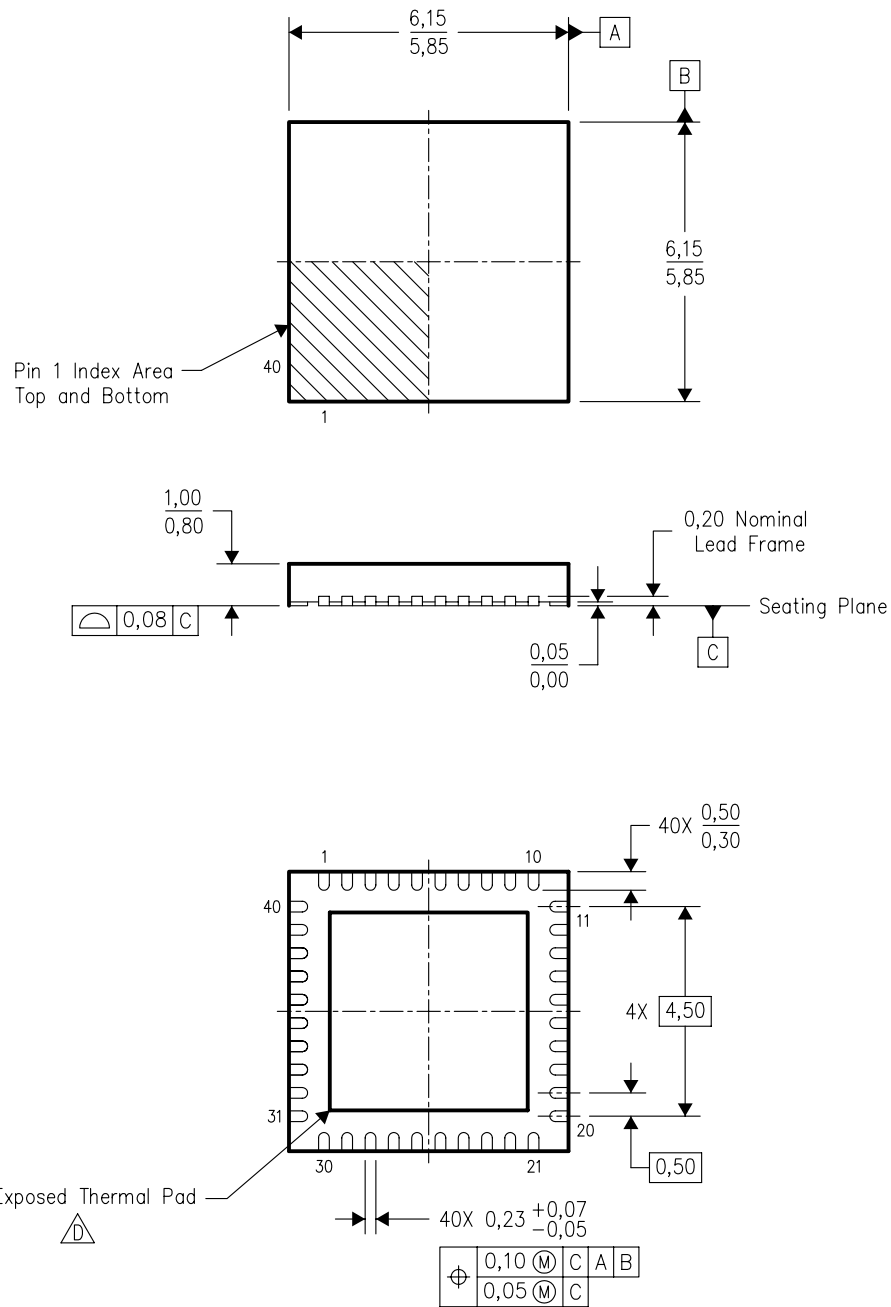

Bottom View

4204276/C 12/2004

- NOTES:
- A. All linear dimensions are in millimeters. Dimensioning and tolerancing per ASME Y14.5M-1994.
 - B. This drawing is subject to change without notice.
 - C. QFN (Quad Flatpack No-Lead) Package configuration.
 -  The package thermal pad must be soldered to the board for thermal and mechanical performance. See the Product Data Sheet for details regarding the exposed thermal pad dimensions.
 - E. Package complies to JEDEC MO-220 variation VJJD-2.

THERMAL INFORMATION

This package incorporates an exposed thermal pad that is designed to be attached directly to an external heatsink. The thermal pad must be soldered directly to the printed circuit board (PCB). After soldering, the PCB can be used as a heatsink. In addition, through the use of thermal vias, the thermal pad can be attached directly to the appropriate copper plane shown in the electrical schematic for the device, or alternatively, can be attached to a special heatsink structure designed into the PCB. This design optimizes the heat transfer from the integrated circuit (IC).

For information on the Quad Flatpack No-Lead (QFN) package and its advantages, refer to Application Report, Quad Flatpack No-Lead Logic Packages, Texas Instruments Literature No. SCBA017. This document is available at www.ti.com.

The exposed thermal pad dimensions for this package are shown in the following illustration.

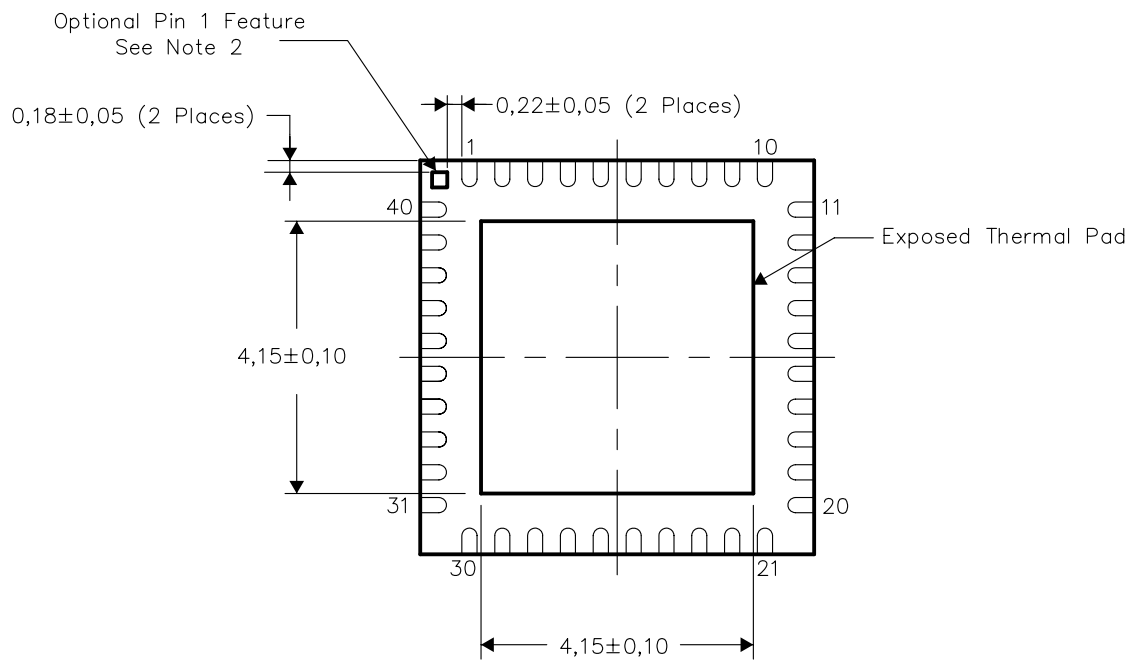

Bottom View

NOTES:

- 1) All linear dimensions are in millimeters
- 2) The Pin 1 Identification mark is an optional feature that may be present on some devices
 In addition, this Pin 1 feature if present is electrically connected to the center thermal pad and therefore should be considered when routing the board layout.

Exposed Thermal Pad Dimensions

RHA (S-PQFP-N40)

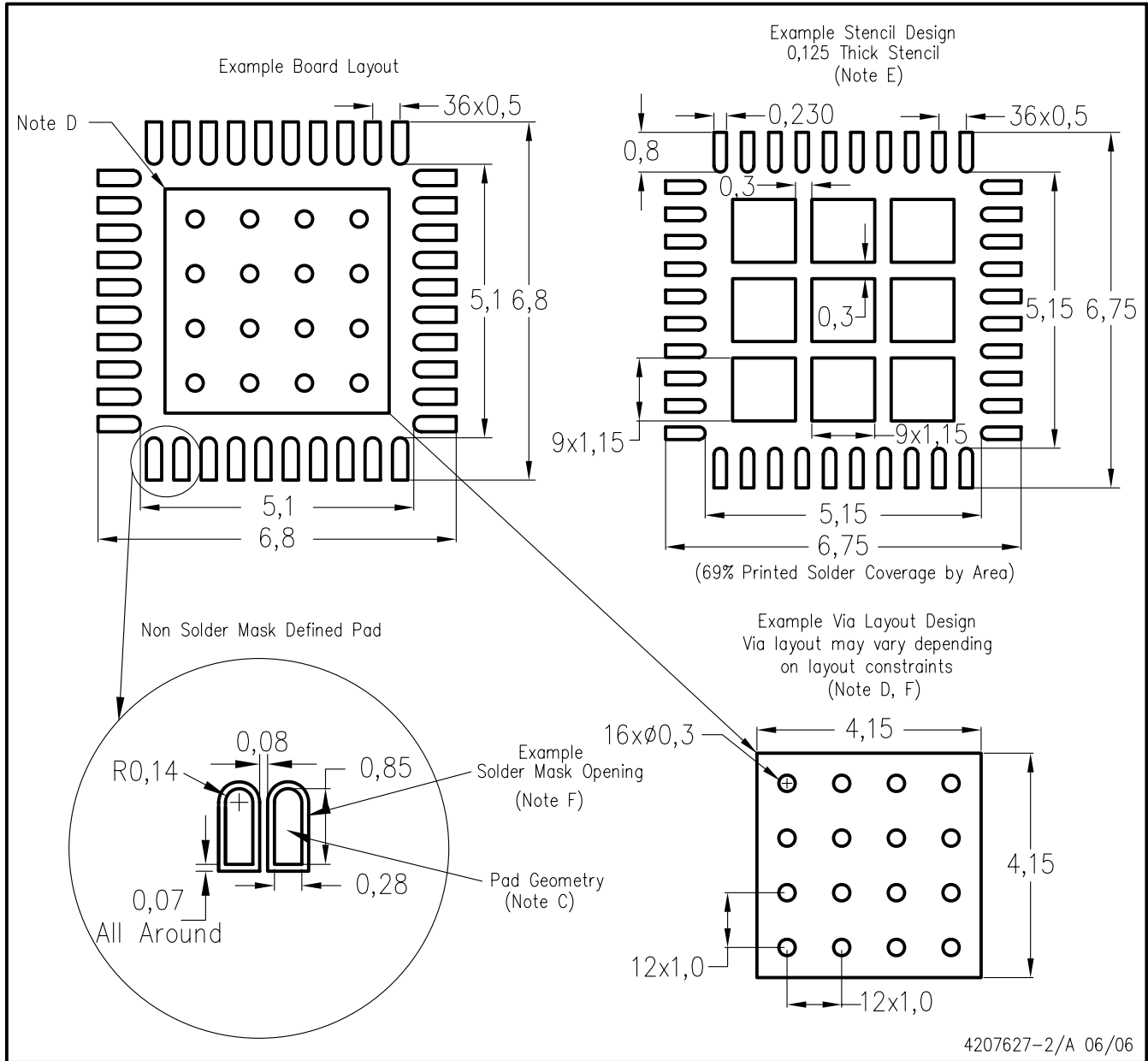

- NOTES:
- A. All linear dimensions are in millimeters.
 - B. This drawing is subject to change without notice.
 - C. Publication IPC-7351 is recommended for alternate designs.
 - D. This package is designed to be soldered to a thermal pad on the board. Refer to Application Note, Quad Flat-Pack Packages, Texas Instruments Literature No. SCBA017, SLUA271, and also the Product Data Sheets for specific thermal information, via requirements, and recommended board layout. These documents are available at www.ti.com <<http://www.ti.com>>.
 - E. Laser cutting apertures with trapezoidal walls and also rounding corners will offer better paste release. Customers should contact their board assembly site for stencil design recommendations. Refer to IPC 7525 for stencil design considerations.
 - F. Customers should contact their board fabrication site for recommended solder mask tolerances and via tenting recommendations for vias placed in the thermal pad.

DA (R-PDSO-G**)

PLASTIC SMALL-OUTLINE PACKAGE

38 PIN SHOWN

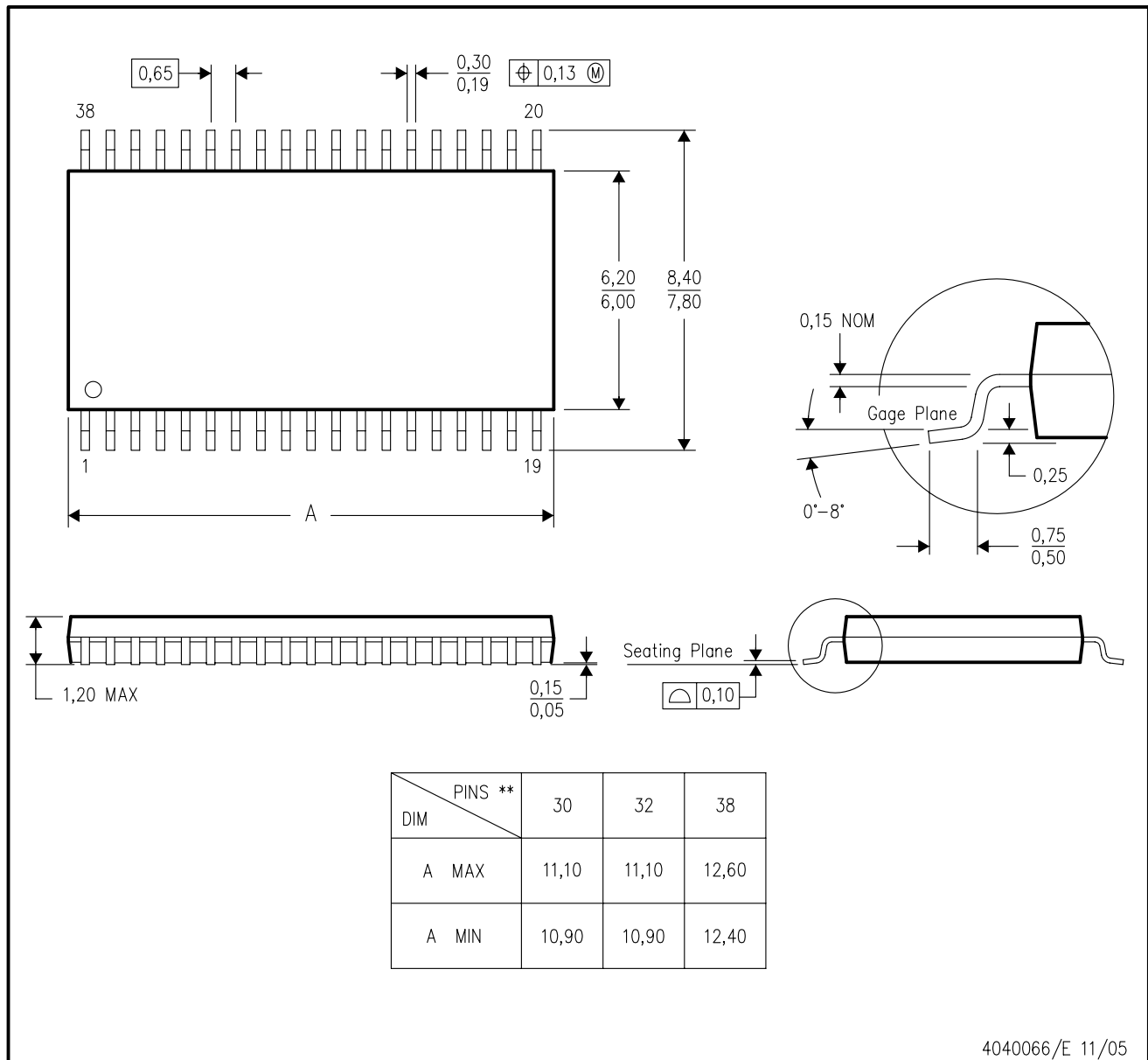

4040066/E 11/05

- NOTES:
- A. All linear dimensions are in millimeters.
 - B. This drawing is subject to change without notice.
 - C. Body dimensions do not include mold flash or protrusion. Mold flash and protrusion shall not exceed 0.15 per side.
 - D. Falls within JEDEC MO-153

IMPORTANT NOTICE

Texas Instruments Incorporated and its subsidiaries (TI) reserve the right to make corrections, modifications, enhancements, improvements, and other changes to its products and services at any time and to discontinue any product or service without notice. Customers should obtain the latest relevant information before placing orders and should verify that such information is current and complete. All products are sold subject to TI's terms and conditions of sale supplied at the time of order acknowledgment.

TI warrants performance of its hardware products to the specifications applicable at the time of sale in accordance with TI's standard warranty. Testing and other quality control techniques are used to the extent TI deems necessary to support this warranty. Except where mandated by government requirements, testing of all parameters of each product is not necessarily performed.

TI assumes no liability for applications assistance or customer product design. Customers are responsible for their products and applications using TI components. To minimize the risks associated with customer products and applications, customers should provide adequate design and operating safeguards.

TI does not warrant or represent that any license, either express or implied, is granted under any TI patent right, copyright, mask work right, or other TI intellectual property right relating to any combination, machine, or process in which TI products or services are used. Information published by TI regarding third-party products or services does not constitute a license from TI to use such products or services or a warranty or endorsement thereof. Use of such information may require a license from a third party under the patents or other intellectual property of the third party, or a license from TI under the patents or other intellectual property of TI.

Reproduction of TI information in TI data books or data sheets is permissible only if reproduction is without alteration and is accompanied by all associated warranties, conditions, limitations, and notices. Reproduction of this information with alteration is an unfair and deceptive business practice. TI is not responsible or liable for such altered documentation. Information of third parties may be subject to additional restrictions.

Resale of TI products or services with statements different from or beyond the parameters stated by TI for that product or service voids all express and any implied warranties for the associated TI product or service and is an unfair and deceptive business practice. TI is not responsible or liable for any such statements.

TI products are not authorized for use in safety-critical applications (such as life support) where a failure of the TI product would reasonably be expected to cause severe personal injury or death, unless officers of the parties have executed an agreement specifically governing such use. Buyers represent that they have all necessary expertise in the safety and regulatory ramifications of their applications, and acknowledge and agree that they are solely responsible for all legal, regulatory and safety-related requirements concerning their products and any use of TI products in such safety-critical applications, notwithstanding any applications-related information or support that may be provided by TI. Further, Buyers must fully indemnify TI and its representatives against any damages arising out of the use of TI products in such safety-critical applications.

TI products are neither designed nor intended for use in military/aerospace applications or environments unless the TI products are specifically designated by TI as military-grade or "enhanced plastic." Only products designated by TI as military-grade meet military specifications. Buyers acknowledge and agree that any such use of TI products which TI has not designated as military-grade is solely at the Buyer's risk, and that they are solely responsible for compliance with all legal and regulatory requirements in connection with such use.

TI products are neither designed nor intended for use in automotive applications or environments unless the specific TI products are designated by TI as compliant with ISO/TS 16949 requirements. Buyers acknowledge and agree that, if they use any non-designated products in automotive applications, TI will not be responsible for any failure to meet such requirements.

Following are URLs where you can obtain information on other Texas Instruments products and application solutions:

| Products | | Applications | |
|-----------------------|--|---------------------|--|
| Amplifiers | amplifier.ti.com | Audio | www.ti.com/audio |
| Data Converters | dataconverter.ti.com | Automotive | www.ti.com/automotive |
| DSP | dsp.ti.com | Broadband | www.ti.com/broadband |
| Interface | interface.ti.com | Digital Control | www.ti.com/digitalcontrol |
| Logic | logic.ti.com | Military | www.ti.com/military |
| Power Mgmt | power.ti.com | Optical Networking | www.ti.com/opticalnetwork |
| Microcontrollers | microcontroller.ti.com | Security | www.ti.com/security |
| RFID | www.ti-rfid.com | Telephony | www.ti.com/telephony |
| Low Power Wireless | www.ti.com/lpw | Video & Imaging | www.ti.com/video |
| | | Wireless | www.ti.com/wireless |

Mailing Address: Texas Instruments, Post Office Box 655303, Dallas, Texas 75265
Copyright © 2007, Texas Instruments Incorporated