

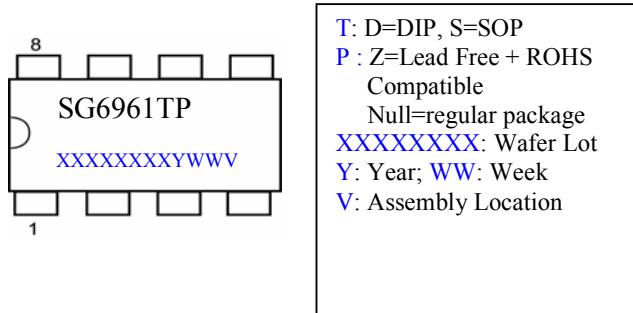

MARKING DIAGRAMS

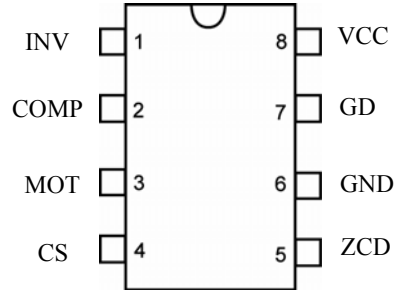

PIN CONFIGURATION



ORDERING INFORMATION

Part Number	Pb-Free	Package
SG6961SZ		8-Pin SOP
SG6961DZ		8-Pin DIP

PIN DESCRIPTIONS

Pin No.	Symbol	Description
1	INV	Inverting input of the error amplifier. INV is connected to the converter output via a resistive divider. This pin is also used for over-voltage clamping and open-loop feedback protection.
2	COMP	The output of the error amplifier. To create a precise clamping protection, a compensation network between this pin and GND is suggested.
3	MOT	A resistor from MOT to GND is used to determine the maximum on-time of the external power MOSFET. The maximum output power of the converter is a function of the maximum on-time.
4	CS	Input to the over-current protection comparator. When the sensed voltage across the sense resistor reaches the internal threshold (0.82V), the switch is turned off to activate cycle-by-cycle current limiting.
5	ZCD	Zero Current Detection. This pin is connected to an auxiliary winding via a resistor to detect the zero crossing of the switch current. When the zero crossing is detected, a new switching cycle is started. If it is connected to GND, the device is disabled.
6	GND	The power ground and signal ground. Placing a 0.1µF decoupling capacitor between the VCC and GND pins is recommended.
7	GD	Totem-pole driver output to drive the external power MOSFET. The clamped gate output voltage is 16.5V.
8	VCC	Driver and control circuit supply voltage.

BLOCK DIAGRAM

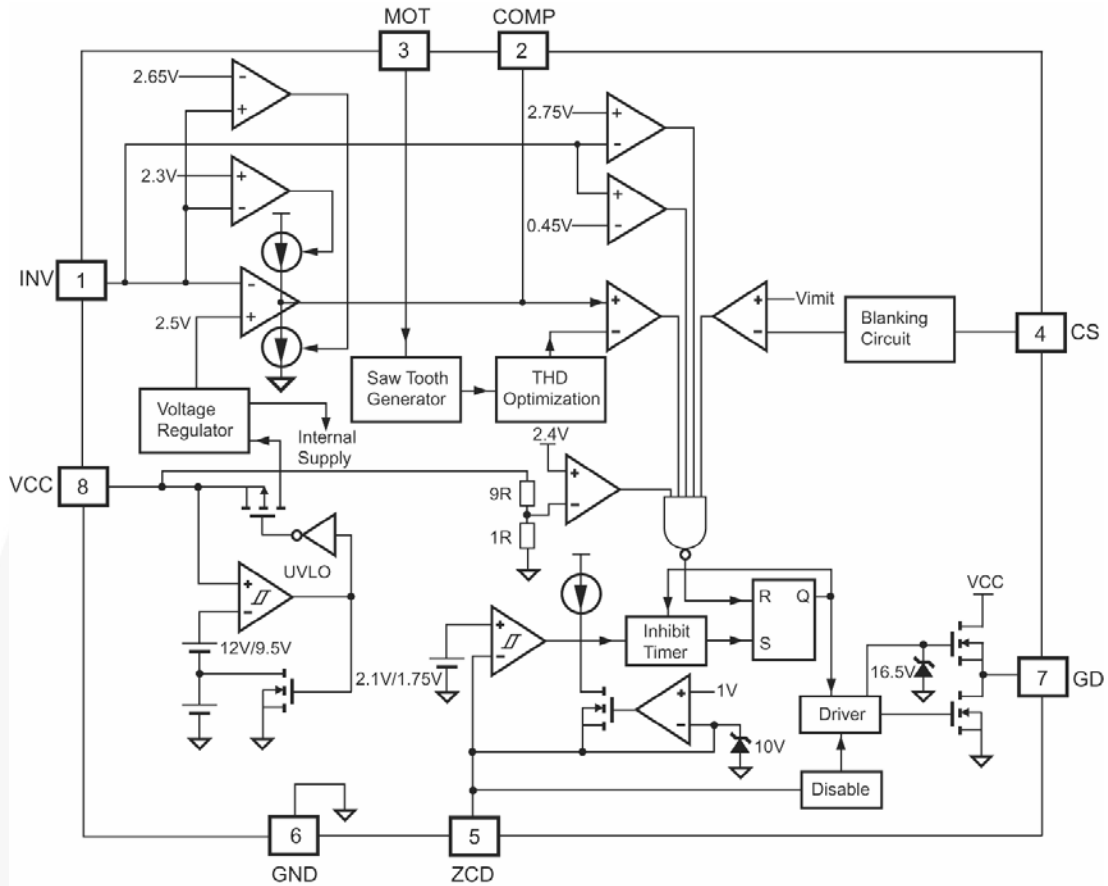

## Power Factor Controller

SG6961

**ABSOLUTE MAXIMUM RATINGS**

Symbol	Parameter	Value	Unit
V <sub>DD</sub>	DC Supply Voltage*	25	V
V <sub>HIGH</sub>	GD	-0.3 to 25.0	V
V <sub>LOW</sub>	Others (INV, COMP, MOT, CS,)	-0.3 to 7.0	V
V <sub>ZCD</sub>	Input Voltage to ZCD Pin	-0.3 to 12.0	V
P <sub>D</sub>	Power Dissipation	DIP-8	800
		SOP-8	400
R <sub>θJA</sub>	Thermal Resistance (Junction-to-Air)	DIP-8	48.45
		SOP-8	62.70
T <sub>J</sub>	Operating Junction Temperature	-40 to + 150	°C
T <sub>STG</sub>	Storage Temperature Range	-65 to + 150	°C
T <sub>L</sub>	Lead Temperature (Wave Soldering or Infrared, 10 Seconds)	260	°C
ESD	Electrostatic Discharge Capability, Human Body Model	2.0	kV
	Electrostatic Discharge Capability, Machine Model	200	V

\* All voltage values, except differential voltages, are given with respect to GND pin.

\* Stresses beyond those listed under "absolute maximum ratings" may cause permanent damage to the device.

**ELECTRICAL CHARACTERISTICS**

V<sub>CC</sub>=15V, T<sub>A</sub>=-20°C~125°C, unless otherwise noted.

**V<sub>CC</sub> Section**

Symbol	Parameter	Test Condition	Min.	Typ.	Max.	Unit
V <sub>OP</sub>	Continuously Operating Voltage				20	V
V <sub>TH-ON</sub>	Turn-On Threshold Voltage		11	12	13	V
V <sub>TH-OFF</sub>	Turn-Off Voltage		8.2	9.5	10.5	V
I <sub>CC-ST</sub>	Start-Up Current	V <sub>CC</sub> =V <sub>TH-ON</sub> -0.16V		10	20	μA
I <sub>CC-OP</sub>	Operating Current	V <sub>CC</sub> =12V, V <sub>CS</sub> =0, C <sub>L</sub> =3nF, F <sub>SW</sub> =50KHz		4.5	6.0	mA
V <sub>CC-OVP</sub>	V <sub>CC</sub> Over-Voltage Protection*			24		V
T <sub>VCC-OVP</sub>	V <sub>CC</sub> OVP Debounce Time*			30		μs

\* Guaranteed by design.

**Error Amplifier Section**

Symbol	Parameter	Test Condition	Min.	Typ.	Max.	Unit
V <sub>REF</sub>	Reference Voltage		2.45	2.50	2.55	V
G <sub>m</sub>	Transconductance*	T <sub>A</sub> =25°C	100	125	150	μmho
V <sub>INVH</sub>	Clamp High Feedback Voltage			2.65	2.70	V
V <sub>INVL</sub>	Clamp Low Feedback Voltage		2.22	2.30		V
V <sub>OUT HIGH</sub>	Output High Voltage		4.8			V
V <sub>OZ</sub>	Zero Duty Cycle Output Voltage		1.15	1.35	1.45	V
V <sub>INV-OVP</sub>	Over-Voltage Protection for INV Input*			2.75		V
V <sub>INV-UVP</sub>	Under-Voltage Protection for INV Input		0.40	0.45	0.50	V
I <sub>COMP</sub>	Source Current	V <sub>INV</sub> =2.35V, V <sub>COMP</sub> =1.5V	7	20		μA
		V <sub>INV</sub> =1.5V	450	800		μA
	Sink Current	V <sub>INV</sub> =2.65V, V <sub>COMP</sub> =5V	10	20		μA

\* Guaranteed by design.

**Power Factor Controller**
**SG6961**
**Current Sense Section ( $V_{LIMIT}$ )**

Symbol	Parameter	Test Condition	Min.	Typ.	Max.	Unit
$V_{PK}$	Threshold Voltage for Peak Current Limit Cycle-by-Cycle Limit	$V_{COMP}=5V$	0.77	0.82	0.87	V
$T_{PKD}$	Propagation Delay				200	ns
$T_{BNK}$	Leading-Edge Blanking Time	$R_{MOT}=24k\Omega$		400	550	ns

**Gate Section**

Symbol	Parameter	Test Condition	Min.	Typ.	Max.	Unit
$V_{Z-OUT}$	Output Voltage Maximum (Clamp)	$V_{CC}=20V$	15.5	16.5	17.5	V
$V_{OL}$	Output Voltage Low	$V_{CC}=15V, I_O=100mA$			1.4	V
$V_{OH}$	Output Voltage High	$V_{CC}=14V, I_O=100mA$	8			V
$T_R$	Rising Time	$V_{CC}=12V, C_L=3nF,$ 20~80%	50	80	160	ns
$T_F$	Falling Time	$V_{CC}=12V, C_L=3nF,$ 80~20%	30	40	70	ns

**Zero Current Detection Section**

Symbol	Parameter	Test Condition	Min.	Typ.	Max.	Unit
$V_{ZCD}$	Input Threshold Voltage Rising Edge	$V_{ZCD}$ Increasing	1.9	2.1	2.3	V
$H_{YS}$ of $V_{ZCD}$	Threshold Voltage Hysteresis	$V_{ZCD}$ Decreasing	0.25	0.35	0.50	V
$V_{ZCD-HIGH}$	Upper Clamp Voltage	$I_{ZCD}=3mA$	8	10	12	V
$V_{ZCD-LOW}$	Lower Clamp Voltage	$I_{ZCD}=-0.5mA$	0			V
$T_{DEAD}$	Maximum Delay from ZCD to Output Turn-On	$V_{COMP}=5V, F_{SW}=60KHz$	100		400	ns
$T_{RESTART}$	Restart Time	Output Turned Off by ZCD	300	500	700	$\mu s$
$T_{INHIB}$	Inhibit Time (Maximum Switching Frequency Limit)	$R_{MOT}=24k\Omega$	1.5	2.5	3.0	$\mu s$
$V_{DIS}$	Disable Threshold		200	250	300	mV
$T_{ZCD-DIS}$	ZCD Disable Debounce Time	$R_{MOT}=24k\Omega, ZCD=100mV$	800			$\mu s$

**Maximum On-Time Section**

Symbol	Parameter	Test Condition	Min.	Typ.	Max.	Unit
$V_{MOT}$	MOT Voltage		1.25	1.30	1.35	V
$T_{ON-MAX}$	Maximum On-Time Programming (Resistor Based)	$R_{MOT}=24k\Omega, V_{CS}=0,$ $V_{COMP}=5V$	21	25	27	$\mu s$

TYPICAL CHARACTERISTICS

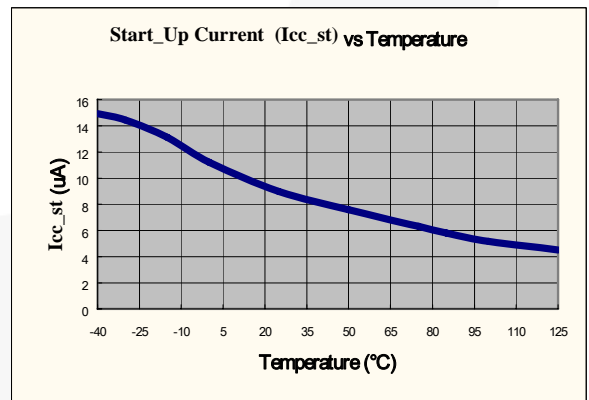
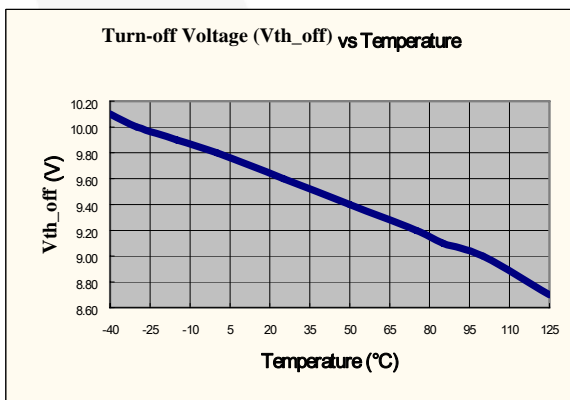
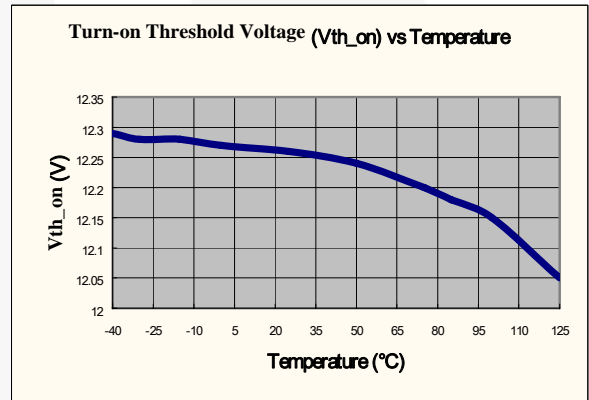
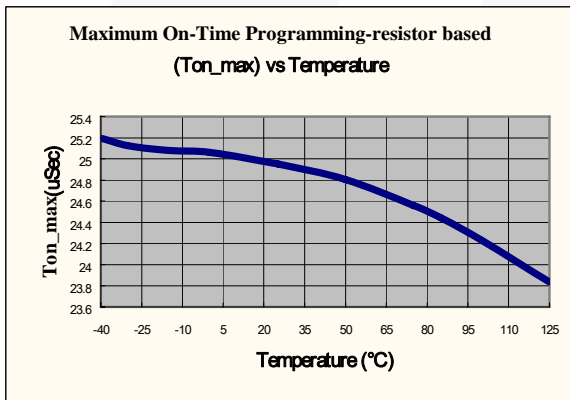
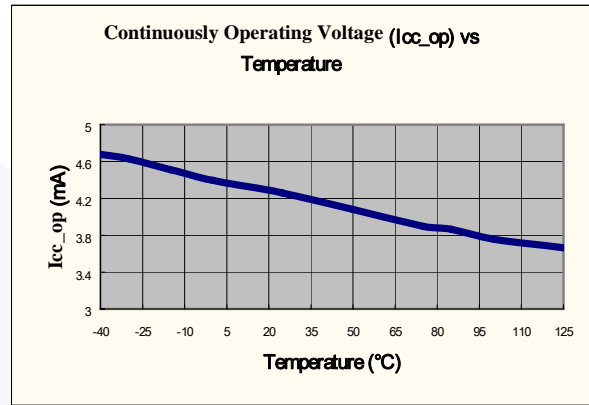
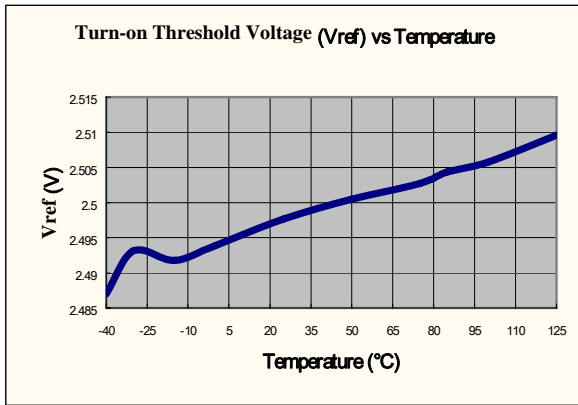

Power Factor Controller

SG6961

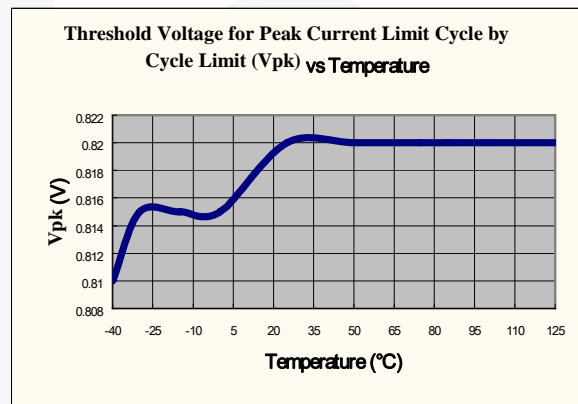
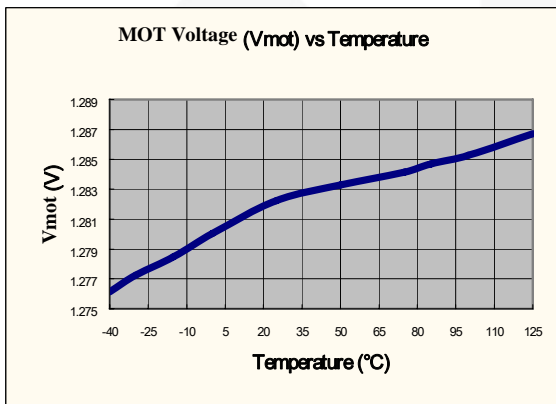
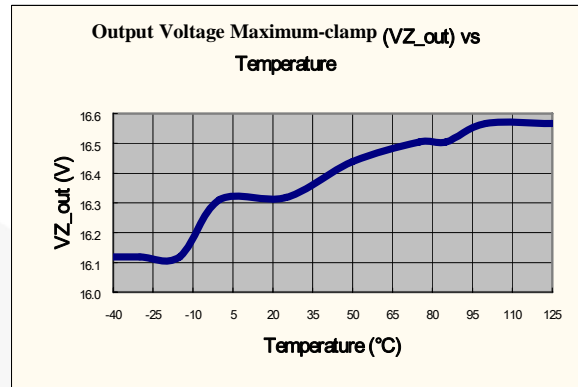
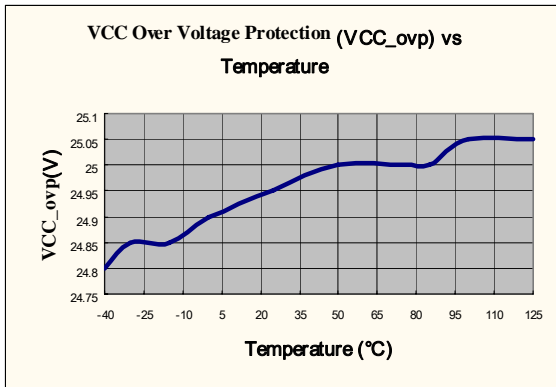

## OPERATION DESCRIPTION

### Error Amplifier

The inverting input of the error amplifier is referenced to INV. The output of the error amplifier is referenced to COMP. The non-inverting input is internally connected to a fixed  $2.5V \pm 2\%$  voltage. The output of the error amplifier is used to determine the on-time of the PWM output and regulate the output voltage. To achieve a low input current THD, the variation of the on-time within one input AC cycle should be very small. A multi-vector error amplifier is built in to provide fast transient response and precise output voltage clamping.

For SG6961, connecting a capacitance, such as  $1\mu F$ , between COMP and GND is suggested. The error amplifier is a transconductance amplifier that converts voltage to current with a  $125\mu mho$ .

### Start-Up Current

Typical start-up current is less than  $20\mu A$ . This ultra-low start-up current allows the usage of a high resistance, low-wattage start-up resistor. For example,  $1M\Omega / 0.25W$  start-up resistor and a  $10\mu F / 25V$  ( $V_{CC}$  hold-up) capacitor are recommended for an AC-to-DC power adaptor with a wide input range  $85$  to  $265V_{AC}$ .

### Operating Current

Operating current is typically  $4.5mA$ . The low operating current enables better efficiency and reduces the requirement of  $V_{CC}$  hold-up capacitance.

### Maximum On-Time Operation

Given a fixed inductor value and maximum output power, the relation between on-time and line voltage is:

$$t_{on} = \frac{2 \cdot L \cdot P_o}{V_{rms}^2 \cdot \eta} \quad (1)$$

If the line voltage is too low or the inductor value is too high,  $T_{ON}$  is too long. To avoid extra low operating frequency and achieve brownout protection, the maximum value of  $T_{ON}$  is programmable by a resistor,  $R_I$ , connected between MOT and GND. A  $24k\Omega$  resistor  $R_I$  generates corresponds to  $25\mu s$  maximum on-time.

$$t_{on(max)} = R_I(k\Omega) \cdot \frac{25}{24}(\mu s) \quad (2)$$

The range of the maximum on-time is designed as  $10 \sim 50\mu s$ .

### Peak Current Limiting

The switch current is sensed by one resistor. The signal is fed into CS pin and an input terminal of a comparator. A high voltage in the CS pin terminates a switching cycle immediately and cycle-by-cycle current limit is achieved. The designed threshold of the protection point is  $0.82V$ .

### Leading-Edge Blanking

A turn on spike on CS pin occurs when the power MOSFET is switched on. At the beginning of each switching pulse, the current-limit comparator is disabled for  $\sim 400ns$  to avoid premature termination. The gate drive output cannot be switched off during the blanking period. Conventional RC filtering is not necessary; the propagation delay of current limit protection can be minimized.

### Under-Voltage Lockout (UVLO)

The turn-on and turn-off threshold voltages are fixed internally at  $12V / 9.5V$  for SG6961. This hysteresis behavior guarantees a one-shot start-up with proper start-up resistor and hold-up capacitor. With an ultra-low start-up current of  $20\mu A$ , one  $1M\Omega$  resistor,  $R_{IN}$ , is sufficient for start-up under low input line voltage,  $85V_{RMS}$ . Power dissipation on  $R_{IN}$  is less than  $0.1W$  even under high line ( $V_{AC} = 265V_{RMS}$ ) conditions.

### Output Driver

With low on resistance and high current driving capability, the output driver can drive an external capacitive load larger than  $3000pF$ . Cross conduction current is avoided to minimize heat dissipation, such that efficiency and reliability can be improved. This output driver is internally equipped with clamped by a  $16.5V$  Zener diode.



### Zero Current Detection

The zero current detection of the inductor is achieved using its auxiliary winding. When the stored energy of the inductor is fully released to output, the voltage on ZCD goes down and a new switching cycle is enabled after a ZCD trigger. The power MOSFET is always turned on with zero inductor current, such that turn-on loss and noise can be minimized. The converter works in boundary mode, such that the peak inductor current is always exactly twice of the average current. Moreover, a natural power factor correction function is achieved with the low-bandwidth on time modulation. An inherent maximum off-time is built in to ensure proper start-up operation. In addition, this pin can be used as a synchronous input.

### Noise Immunity

Noise on the current sense or control signal can cause significant pulse-width jitter, particularly in the boundary-mode operation. Slope compensation and built-in debounce circuitry alleviate this problem. Note that the SG6961 has a single ground pin; therefore, high sink current at the output cannot be returned separately. Good high-frequency or RF layout practices should be followed. Avoid long PCB traces and component leads. Locating compensation and filter components near to the SG6961 and increasing the power MOSFET gate resistance improve performance.

Power Factor Controller

SG6961

REFERENCE CIRCUIT: SG6961 180W

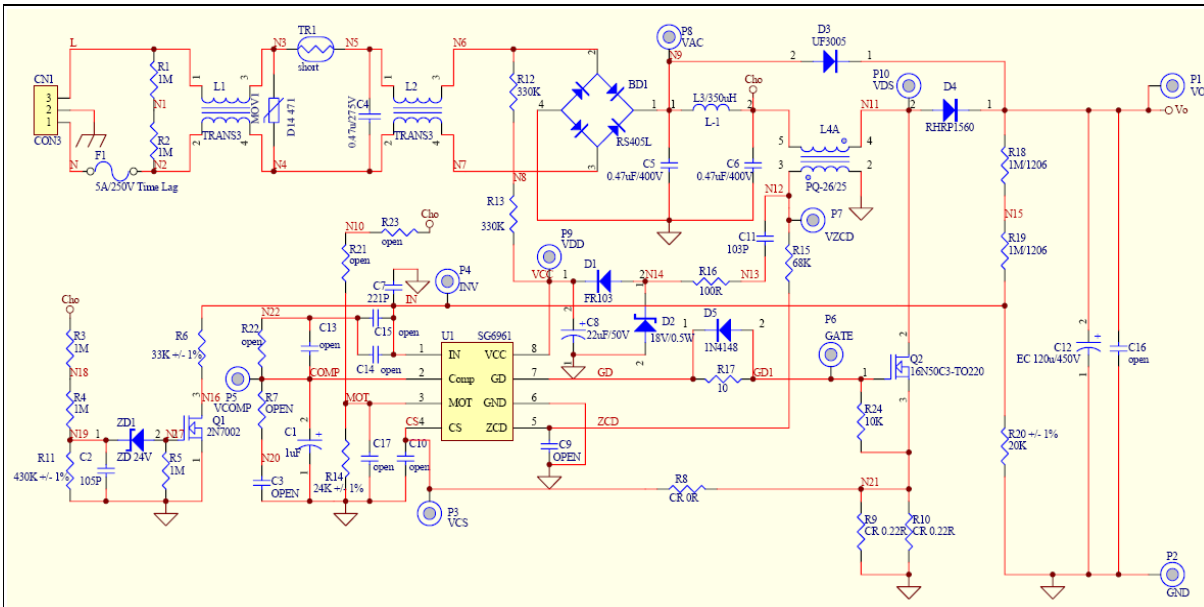

BOM

Component	Symbol
Resistor 1MΩ +/- 5% SMD 1206	R1,R2,R3,R4,R5,R18,R19
Resistor 33KΩ +/- 1% SMD 1206	R6
Resistor 0Ω +/- 1% SMD 1206	R8
Metal-Oxide Resistor 1W-S 0Ω22 +/-5%	R9,R10
Resistor 430KΩ +/-1% SMD 0805	R11
Resistor 330KΩ +/-1% SMD 1206	R12,R13
Resistor 24KΩ +/-1% SMD 1206	R14
Resistor 68KΩ +/-5% SMD 1206	R15
Resistor 100Ω +/-5% SMD 1206	R16
Resistor 10Ω +/-1% SMD 1206	R17
Resistor 20KΩ +/-1% SMD 1206	R20
Electrolytic Capacitor 1µF 50V 105°C	C1
MLCC 105P 50V SMD 1206	C2
X1 Capacitor 0.47µF 275V +/-20%	C4
MPE Capacitor 0.47µF 450V +/-10%	C5,C6
MLCC 221P 50V +/-10% SMD 0805	C7
Electrolytic Capacitor 22µF 50V 85°C	C8
MLCC 103P 50V +/-10% SMD 1206	C11
Electrolytic Capacitor 120µF 450V 105°C	C12
FUSE 250V 5A Ceramic Time-Lag	F1
TRN0194 Common Choke 4.5mH	L1
TRN0195 Common Choke 7.5mH(min)	L2
TRN0193 Inductor(T80-26) 350µH	L3

**Power Factor Controller**

**SG6961**

Component	Symbol
TRN0196 PFC Choke 210μH PQ-26/25	L4A
Varistor 14ψ 471	MOV1
JUMPER WIRE 0.8ψ(mm)	JP1,JP2,JP3,JP4,TR1
Rectifier KBL06 4A 600V	BD1
Diode FR103 TAPING	D1
Zener Diode1/2W 18V	D2
Diode UF3005 3A 600V	D3
Diode Fairchild RHRP1560 15A 600V TO-220	D4
Diode 1N4148 SMD	D5
ZENER Diode 1/2W 24V SMD	ZD1
Diode 2N7002 SMD	Q1
MOSFET Infineon 16N50C3 16A 500V TO-220	Q2

PACKAGE INFORMATION

8PINS-DIP(D)

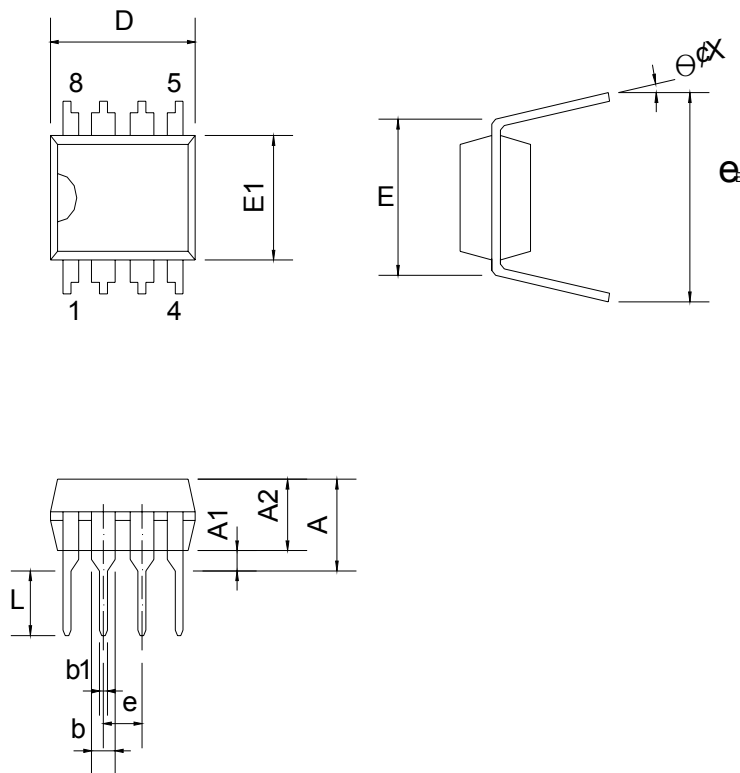

Dimensions

Symbol	Millimeter			Inch		
	Min.	Typ.	Max.	Min.	Typ.	Max.
A			5.334			0.210
A1	0.381			0.015		
A2	3.175	3.302	3.429	0.125	0.130	0.135
b		1.524			0.060	
b1		0.457			0.018	
D	9.017	9.271	10.160	0.355	0.365	0.400
E		7.620			0.300	
E1	6.223	6.350	6.477	0.245	0.250	0.255
e		2.540			0.100	
L	2.921	3.302	3.810	0.115	0.130	0.150
$e_B$	8.509	9.017	9.525	0.335	0.355	0.375
$\theta^\circ$	0°	7°	15°	0°	7°	15°

8PINS-SOP(S)

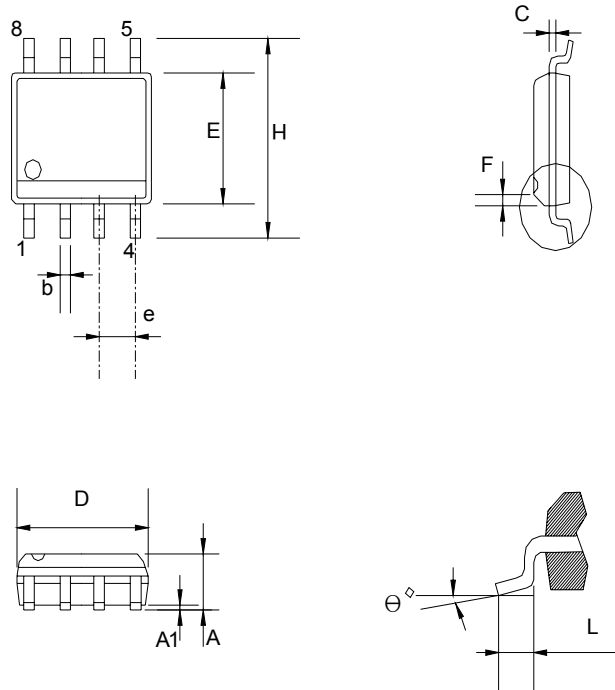

Dimensions

Symbol	Millimeter			Inch		
	Min.	Typ.	Max.	Min.	Typ.	Max.
A	1.346		1.752	0.053		0.069
A1	0.101		0.254	0.004		0.010
b		0.406			0.016	
c		0.203			0.008	
D	4.648		4.978	0.183		0.196
E	3.810		3.987	0.150		0.157
e	1.016	1.270	1.524	0.040	0.050	0.060
F		0.381X45°			0.015X45°	
H	5.791		6.197	0.228		0.244
L	0.406		1.270	0.016		0.050
theta°	0°		8°	0°		8°

**Power Factor Controller**

**SG6961**



**TRADEMARKS**

The following are registered and unregistered trademarks and service marks Fairchild Semiconductor owns or is authorized to use and is not intended to be an exhaustive list of all such trademarks.

- |                                      |  |  |                                  |
|--------------------------------------|--|--|----------------------------------|
| ACEx <sup>®</sup>                    | Green FPS <sup>™</sup>   | Power247 <sup>®</sup>                  | SuperSOT <sup>™</sup> -8         |
| Build it Now <sup>™</sup>            | Green FPS <sup>™</sup> e-Series <sup>™</sup>   | POWEREDGE <sup>®</sup>                 | SyncFET <sup>™</sup>             |
| CorePLUS <sup>™</sup>                | GTO <sup>™</sup>   | Power-SPM <sup>™</sup>                 | The Power Franchise <sup>®</sup> |
| CROSSVOLT <sup>™</sup>               | i-Lo <sup>™</sup>  | PowerTrench <sup>®</sup>               | <b>the power franchise</b>       |
| CTL <sup>™</sup>                     | IntelliMAX <sup>™</sup>  | Programmable Active Droop <sup>™</sup> | TinyBoost <sup>™</sup>           |
| Current Transfer Logic <sup>™</sup>  | ISOPLANAR <sup>™</sup>   | QFET <sup>®</sup>                      | TinyBuck <sup>™</sup>            |
| EcoSPARK <sup>®</sup>                | MegaBuck <sup>™</sup>  | QS <sup>™</sup>                        | TinyLogic <sup>®</sup>           |
| <b>f</b> <sup>®</sup>                | MICROCOUPLER <sup>™</sup>  | QT Optoelectronics <sup>™</sup>        | TINYOPTO <sup>™</sup>            |
| Fairchild <sup>®</sup>               | MicroFET <sup>™</sup>  | Quiet Series <sup>™</sup>              | TinyPower <sup>™</sup>           |
| Fairchild Semiconductor <sup>®</sup> | MicroPak <sup>™</sup>  | RapidConfigure <sup>™</sup>            | TinyPWM <sup>™</sup>             |
| FACT Quiet Series <sup>™</sup>       | MillerDrive <sup>™</sup>   | SMART START <sup>™</sup>               | TinyWire <sup>™</sup>            |
| FACT <sup>®</sup>                    | Motion-SPM <sup>™</sup>  | SPM <sup>®</sup>                       | μSerDes <sup>™</sup>             |
| FAST <sup>®</sup>                    | OPTOLOGIC <sup>®</sup>   | STEALTH <sup>™</sup>                   | UHC <sup>®</sup>                 |
| FastvCore <sup>™</sup>               | OPTOPLANAR <sup>®</sup>  | SuperFET <sup>™</sup>                  | UniFET <sup>™</sup>              |
| FPS <sup>™</sup>                     |  <sup>®</sup> | SuperSOT <sup>™</sup> -3               | VCX <sup>™</sup>                 |
| FRFET <sup>®</sup>                   | PDP-SPM <sup>™</sup>   | SuperSOT <sup>™</sup> -6               |                                  |
| Global Power Resource <sup>SM</sup>  | Power220 <sup>®</sup>  |  |                                  |

**DISCLAIMER**

FAIRCHILD SEMICONDUCTOR RESERVES THE RIGHT TO MAKE CHANGES WITHOUT FURTHER NOTICE TO ANY PRODUCTS HEREIN TO IMPROVE RELIABILITY, FUNCTION, OR DESIGN. FAIRCHILD DOES NOT ASSUME ANY LIABILITY ARISING OUT OF THE APPLICATION OR USE OF ANY PRODUCT OR CIRCUIT DESCRIBED HEREIN; NEITHER DOES IT CONVEY ANY LICENSE UNDER ITS PATENT RIGHTS, NOR THE RIGHTS OF OTHERS. THESE SPECIFICATIONS DO NOT EXPAND THE TERMS OF FAIRCHILD'S WORLDWIDE TERMS AND CONDITIONS, SPECIFICALLY THE WARRANTY THEREIN, WHICH COVERS THESE PRODUCTS.

**LIFE SUPPORT POLICY**

FAIRCHILD'S PRODUCTS ARE NOT AUTHORIZED FOR USE AS CRITICAL COMPONENTS IN LIFE SUPPORT DEVICES OR SYSTEMS WITHOUT THE EXPRESS WRITTEN APPROVAL OF FAIRCHILD SEMICONDUCTOR CORPORATION.

As used herein:

1. Life support devices or systems are devices or systems which, (a) are intended for surgical implant into the body or (b) support or sustain life, and (c) whose failure to perform when properly used in accordance with instructions for use provided in the labeling, can be reasonably expected to result in a significant injury of the user.
2. A critical component in any component of a life support, device, or system whose failure to perform can be reasonably expected to cause the failure of the life support device or system, or to affect its safety or effectiveness.

**PRODUCT STATUS DEFINITIONS**

**Definition of Terms**

Datasheet Identification	Product Status	Definition
Advance Information	Formative or In Design	This datasheet contains the design specifications for product development. Specifications may change in any manner without notice.
Preliminary	First Production	This datasheet contains preliminary data; supplementary data will be published at a later date. Fairchild Semiconductor reserves the right to make changes at any time without notice to improve design.
No Identification Needed	Full Production	This datasheet contains final specifications. Fairchild Semiconductor reserves the right to make changes at any time without notice to improve design.
Obsolete	Not In Production	This datasheet contains specifications on a product that has been discontinued by Fairchild Semiconductor. The datasheet is printed for reference information only.

Rev. 131