

Voltage Regulator

TLE 4274 / 3.3V;2.5V

Features

- Output voltage: 3.3 V/2.5 V \pm 4%
- Current capability 400 mA
- Very low current consumption
- Short-circuit proof
- Reverse polarity proof
- Suitable for use in automotive electronics

Functional Description

The TLE 4274 / 3.3V;2.5V is a voltage regulator available in a SOT223 and TO252 package. The IC regulates an input voltage up to 40 V to $V_{Qrated} = 3.3$ V/2.5 V. The maximum output current is 400 mA. The IC is short-circuit proof and has a shutdown circuit protecting it against overtemperature. The TLE 4274 is also available as 5 V, 8.5 V and 10 V version. Please refer to the data sheet TLE 4274.

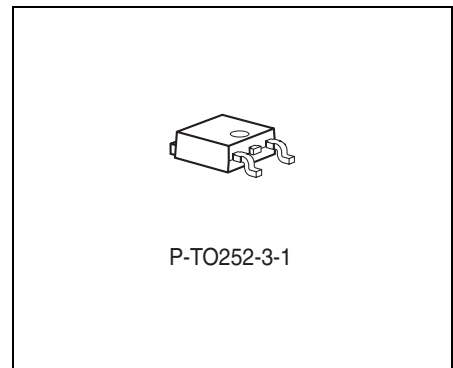
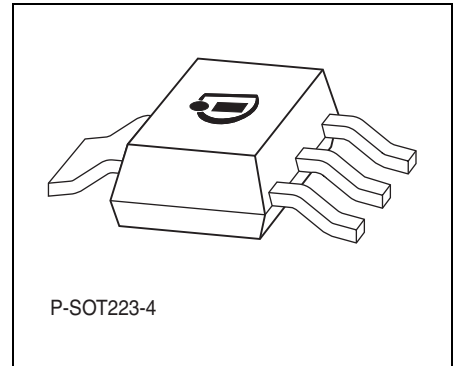

Dimensioning Information on External Components

The input capacitor C_1 is necessary for compensating line influences. Using a resistor of approx. 1 Ω in series with C_1 , the oscillating of input inductivity and input capacitance can be damped. The output capacitor C_Q is necessary for the stability of the regulation circuit. Stability is guaranteed for capacities $C_Q \geq 10$ μ F with an ESR of ≤ 2.5 Ω within the operating temperature range.

Type	Ordering Code	Package
TLE 4274 GSV33	Q67006-A9289	P-SOT223-4-1
TLE 4274 DV33	Q67006-A9348	P-TO252-3-1
TLE 4274 GSV25	Q67006-A9359	P-SOT223-4-1

Circuit Description

The control amplifier compares a reference voltage to a voltage that is proportional to the output voltage and drives the base of the series transistor via a buffer. Saturation control as a function of the load current prevents any oversaturation of the power element. The IC also includes a number of internal circuits for protection against:

- Overload
- Overtemperature
- Reverse polarity

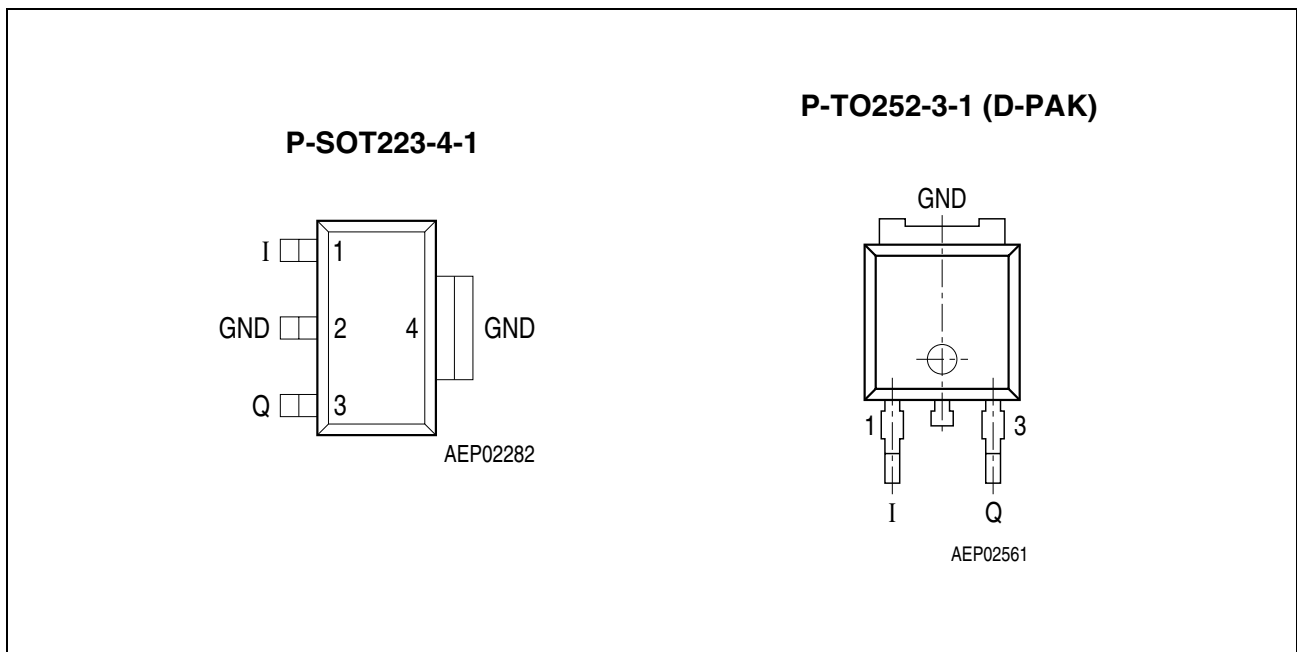

Figure 1 Pin Configuration (top view)

Table 1 Pin Definitions and Functions

Pin No.	Symbol	Function
1	I	Input; block to ground directly at the IC with a ceramic capacitor.
2, 4	GND	Ground; P-TO252-3-1: internally connected to heatsink
3	Q	Output; block to ground with capacitor $C_Q \geq 10 \mu\text{F}$, $\text{ESR} \leq 2.5 \Omega$

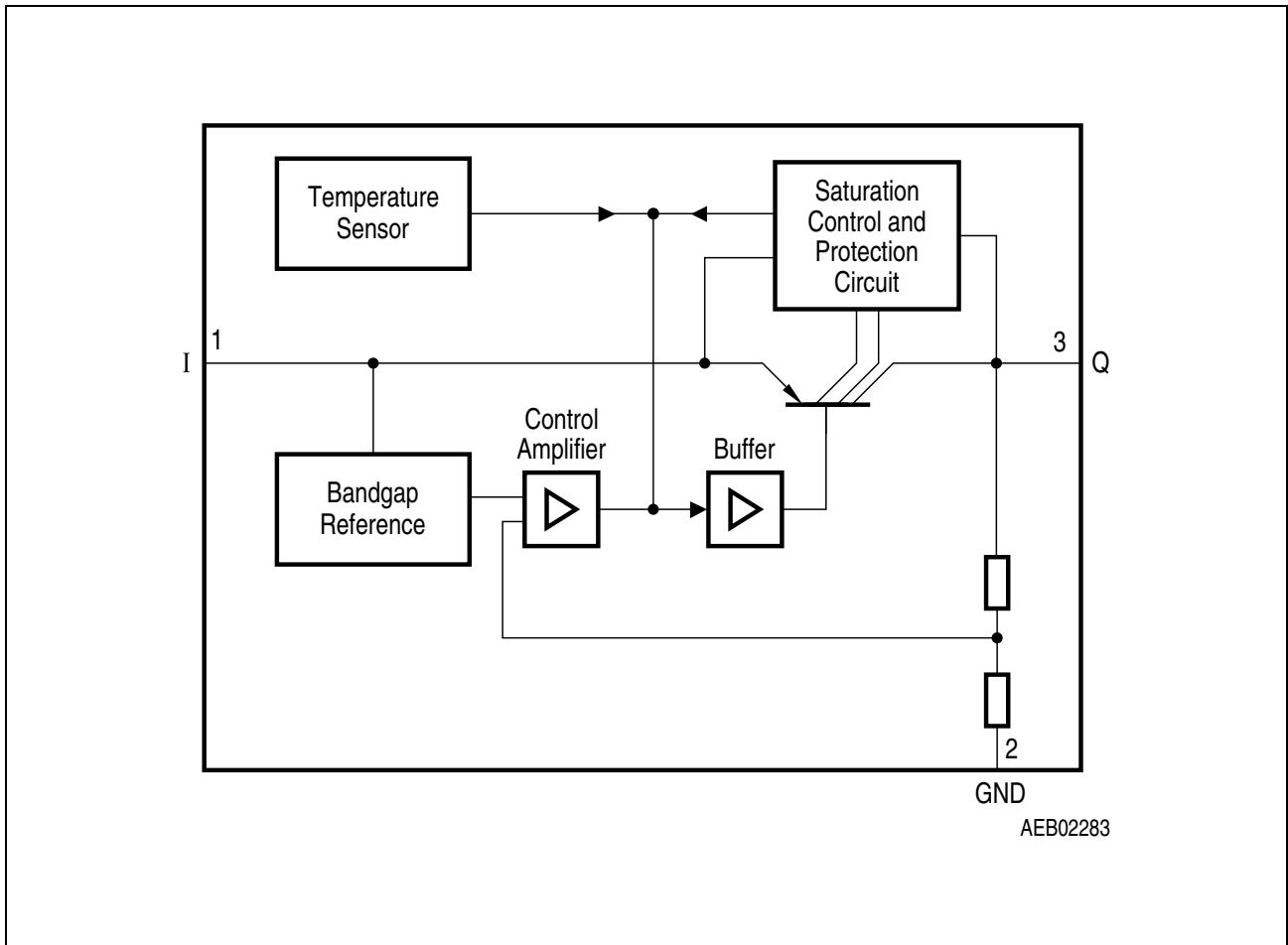

Figure 2 Block Diagram

Table 2 Absolute Maximum Ratings
 $T_j = -40$ to 150 °C

Parameter	Symbol	Limit Values		Unit	Test Condition
		Min.	Max.		
Input					
Voltage	V_I	-42	45	V	–
Current	I_I	–	–	–	Internally limited
Output					
Voltage	V_Q	-1.0	40	V	–
Current	I_Q	–	–	–	Internally limited
Ground					
Current	I_{GND}	–	100	mA	–
Temperature					
Junction temperature	T_j	–	150	°C	–
Storage temperature	T_{stg}	-50	150	°C	–

Note: Maximum ratings are absolute ratings; exceeding any one of these values may cause irreversible damage to the integrated circuit.

Table 3 Operating Range

Parameter	Symbol	Limit Values		Unit	Remarks
		Min.	Max.		
Input voltage	V_I	4.7	40	V	–
Junction temperature	T_j	-40	150	°C	–
Thermal Resistance					
Junction ambient	R_{thja}	–	100	K/W	SOT223 ¹⁾
Junction ambient	R_{thja}	–	70	K/W	TO252 ²⁾
Junction case	R_{thjc}	–	25	K/W	SOT223
Junction case	R_{thjc}	–	4	K/W	TO252

1) Soldered in, 1 cm² copper area at pin 4, FR4

2) Soldered in, minimal footprint, FR4

Table 4 Characteristics
 $V_I = 6 \text{ V}; -40 \text{ }^\circ\text{C} < T_j < 150 \text{ }^\circ\text{C}$ (unless otherwise specified)

Parameter	Symbol	Limit Values			Unit	Measuring Condition
		Min.	Typ.	Max.		
Output voltage V33-Version	V_Q	3.17	3.3	3.44	V	$5 \text{ mA} < I_Q < 400 \text{ mA}$ $4.7 \text{ V} < V_I < 28 \text{ V}$
Output voltage V33-Version	V_Q	3.17	3.3	3.44	V	$5 \text{ mA} < I_Q < 200 \text{ mA}$ $4.7 \text{ V} < V_I < 40 \text{ V}$
Output voltage V25-Version	V_Q	2.4	2.5	2.6	V	$5 \text{ mA} < I_Q < 400 \text{ mA}$ $4.7 \text{ V} < V_I < 28 \text{ V}$
Output voltage V25-Version	V_Q	2.4	2.5	2.6	V	$5 \text{ mA} < I_Q < 200 \text{ mA}$ $4.7 \text{ V} < V_I < 40 \text{ V}$
Output current limitation ¹⁾	I_Q	400	600	–	mA	–
Current consumption; $I_q = I_I - I_Q$	I_q	–	100	220	μA	$I_Q = 1 \text{ mA}$
Current consumption; $I_q = I_I - I_Q$	I_q	–	8	15	mA	$I_Q = 250 \text{ mA}$
Current consumption; $I_q = I_I - I_Q$	I_q	–	20	30	mA	$I_Q = 400 \text{ mA}$
Drop voltage ¹⁾ V33-Version	V_{dr}	–	0.7	1.2	V	$I_Q = 300 \text{ mA}$ $V_{dr} = V_I - V_Q$
Drop voltage ¹⁾ V25-Version	V_{dr}	–	1.0	2.0	V	$I_Q = 300 \text{ mA}$ $V_{dr} = V_I - V_Q$
Load regulation	ΔV_Q	–	40	70	mV	$I_Q = 5 \text{ mA to } 300 \text{ mA};$ $V_I = 6 \text{ V}$
Line regulation	ΔV_Q	–	10	25	mV	$\Delta V_I = 12 \text{ V to } 32 \text{ V}$ $I_Q = 5 \text{ mA}$
Power supply ripple rejection	$PSRR$	–	60	–	dB	$f_r = 100 \text{ Hz};$ $V_r = 0.5 \text{ Vpp}$
Temperature output voltage drift	dV_Q/dT	–	0.5	–	mV/K	–

¹⁾ Measured when the output voltage V_Q has dropped 100 mV from the nominal value obtained at $V_I = 6 \text{ V}$.

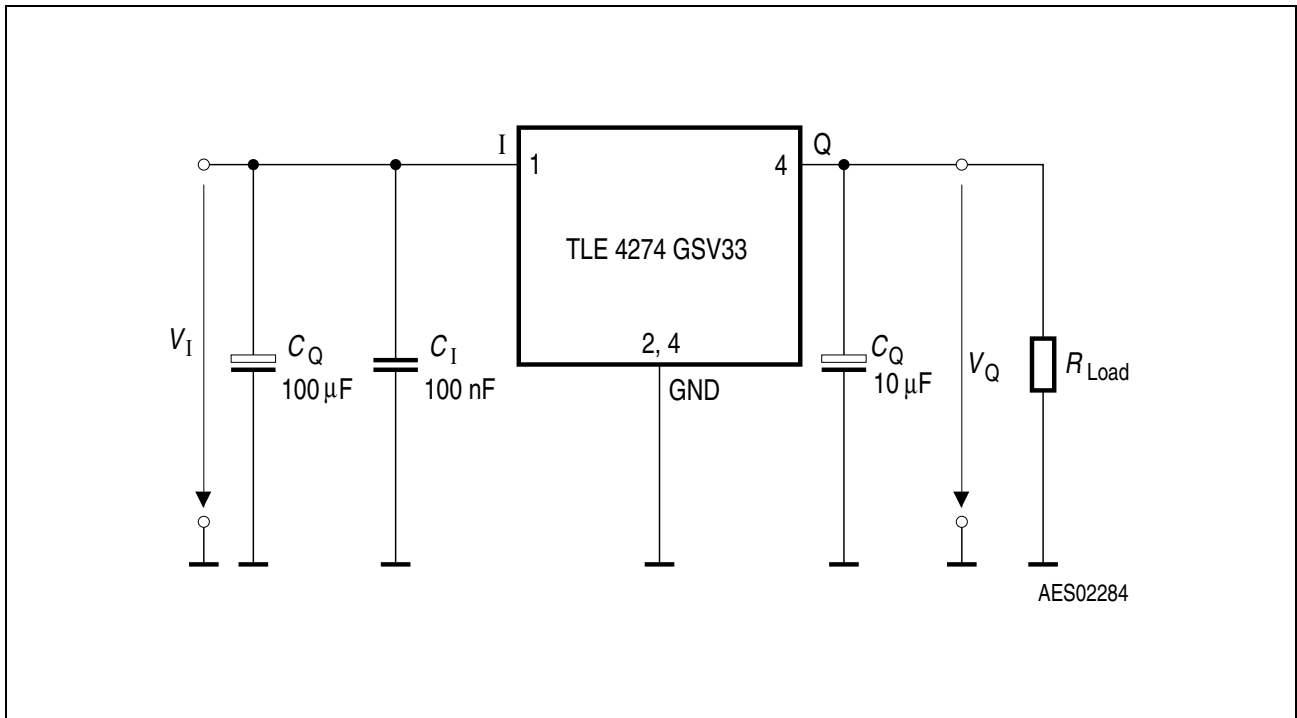

Figure 3 Measuring Circuit

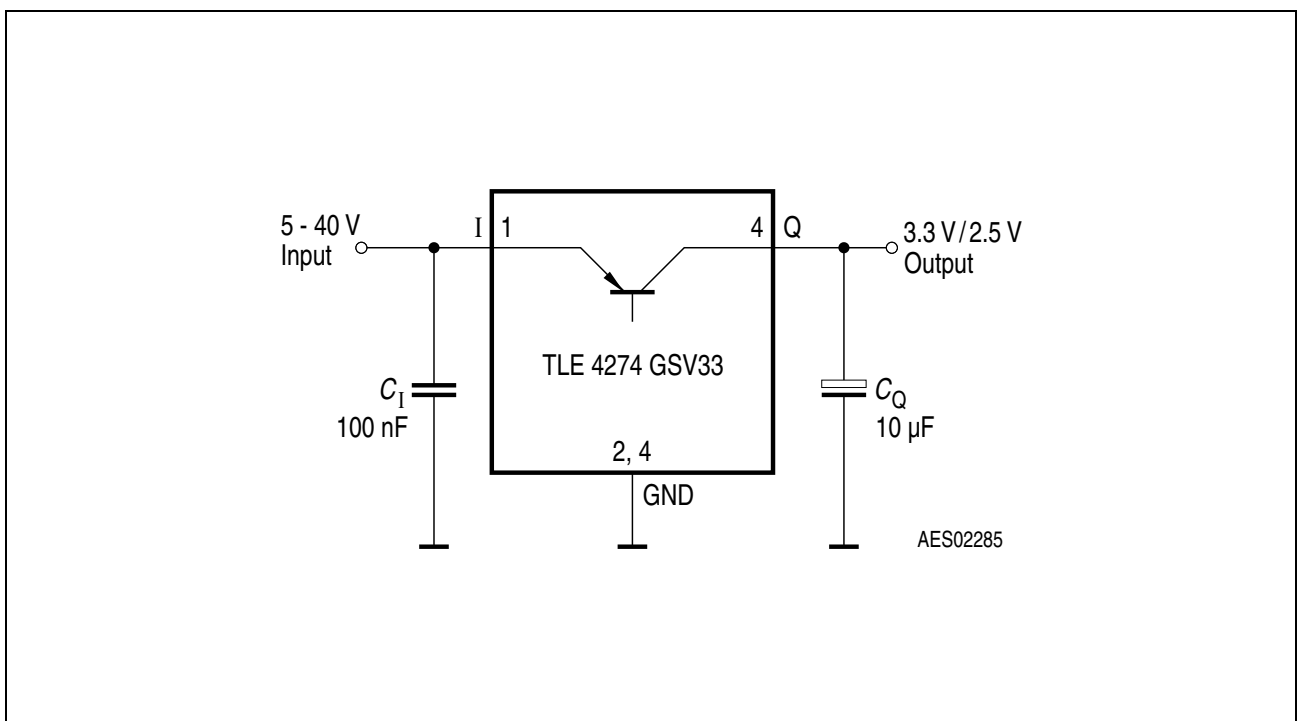
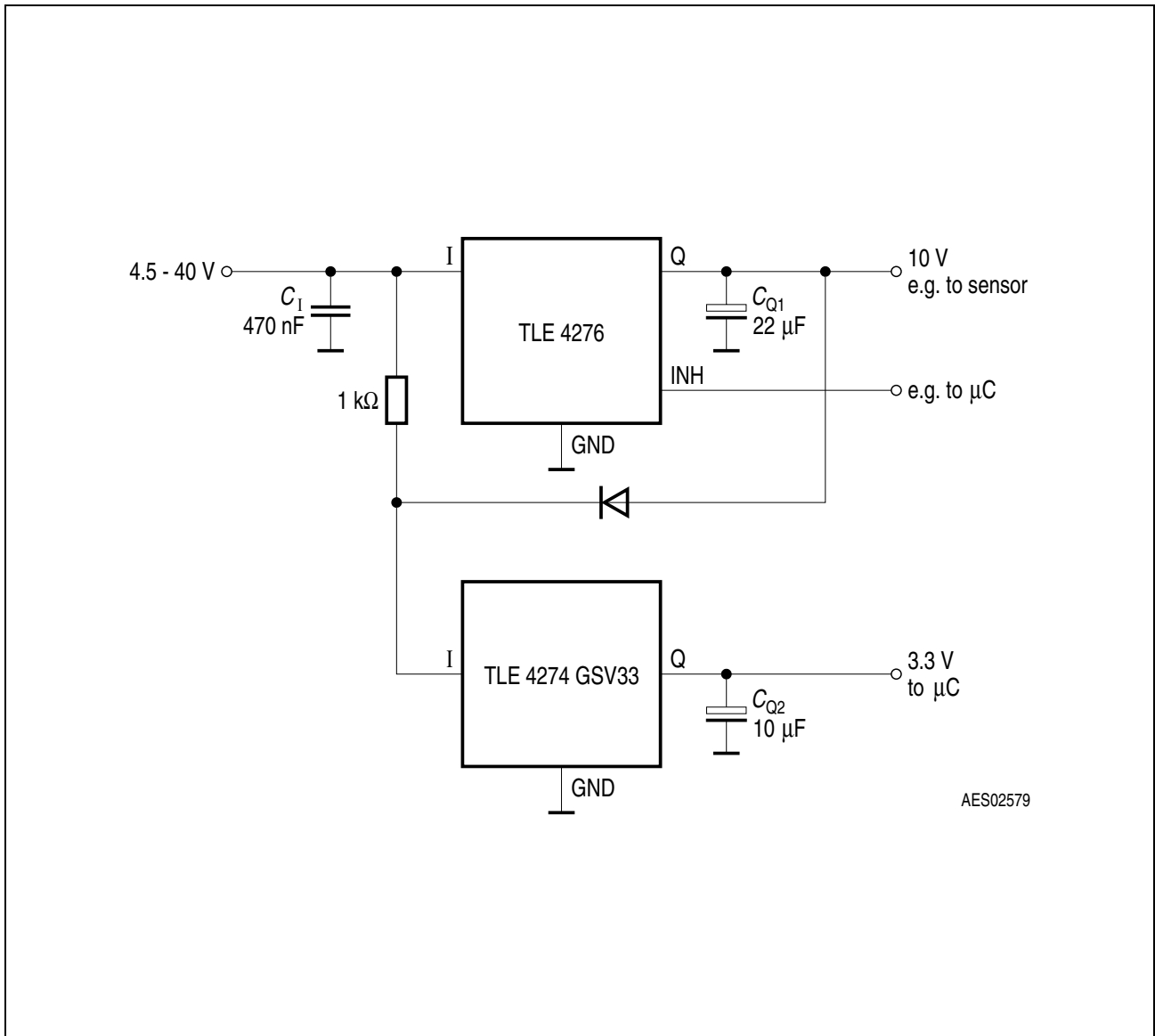

Figure 4 Application Circuit



AES02579

Figure 5 Application Example

Typical Performance Characteristics

Output Voltage V_Q versus Junction Temperature T_j (V33-Version)

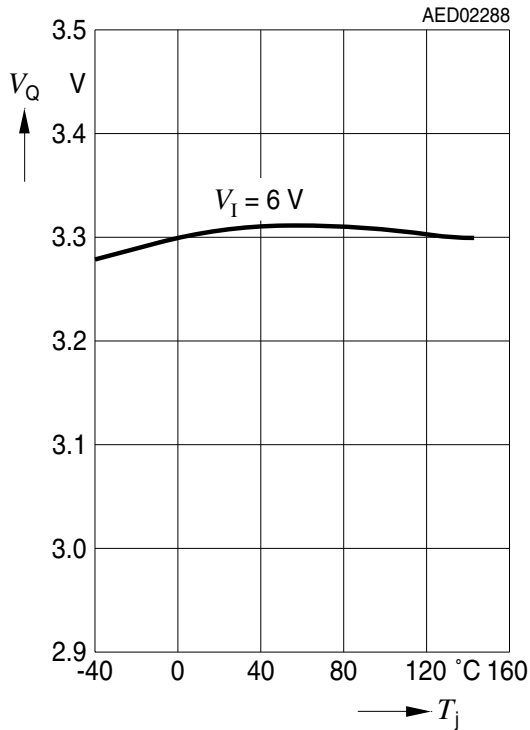

Output Voltage V_Q versus Junction Temperature T_j (V25-Version)

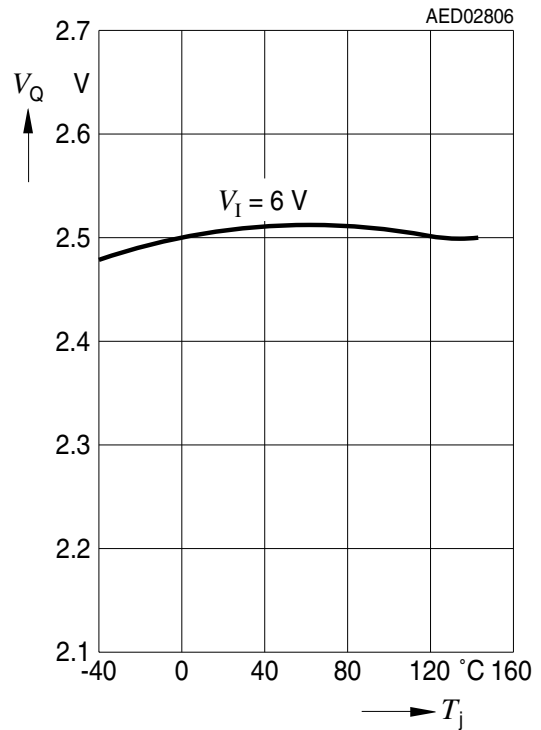

Input Current I_q versus Input Voltage V_I (V33-Version)

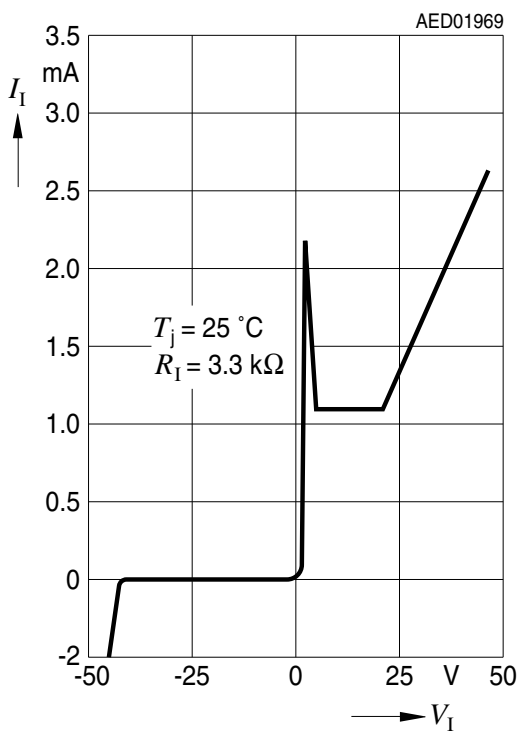

Input Current I_q versus Input Voltage V_I (V25-Version)

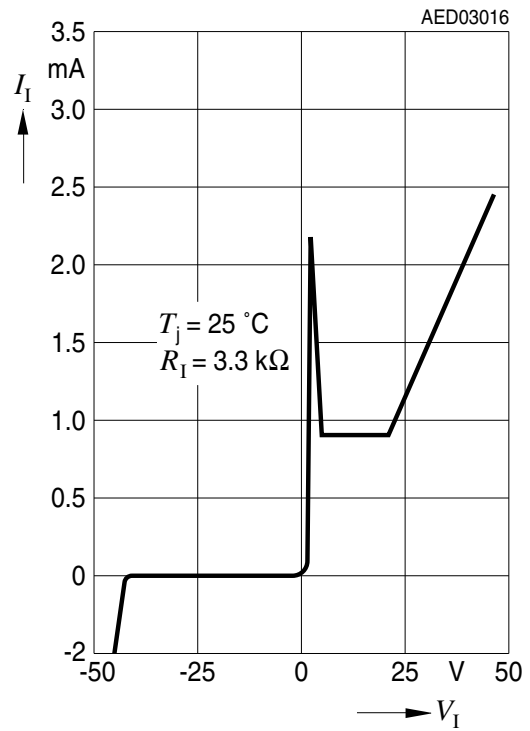

Current Consumption I_q versus Output Current I_Q (low load)

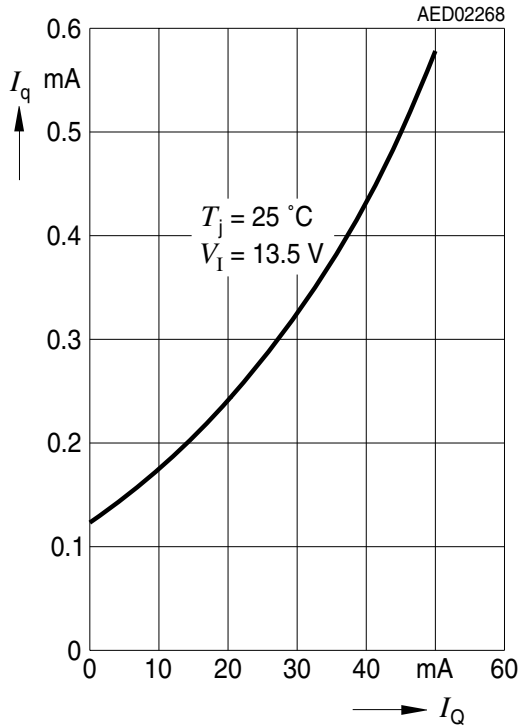

Current Consumption I_q versus Output Current I_Q (high load)

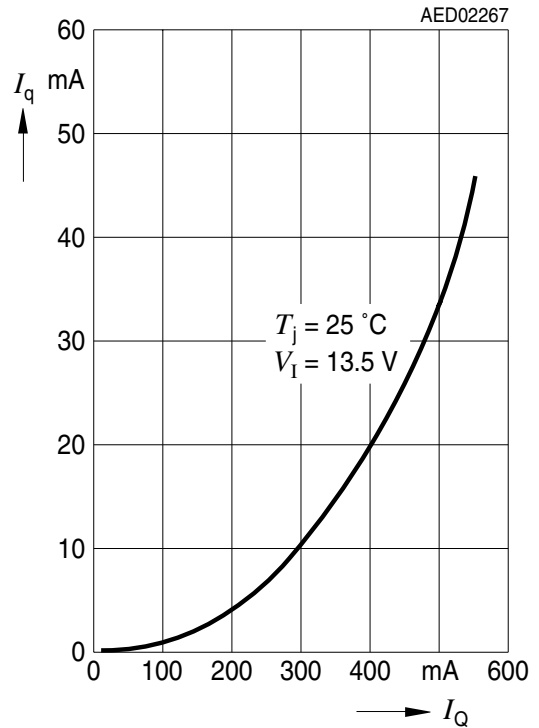

Output Current I_Q versus Input Voltage V_I

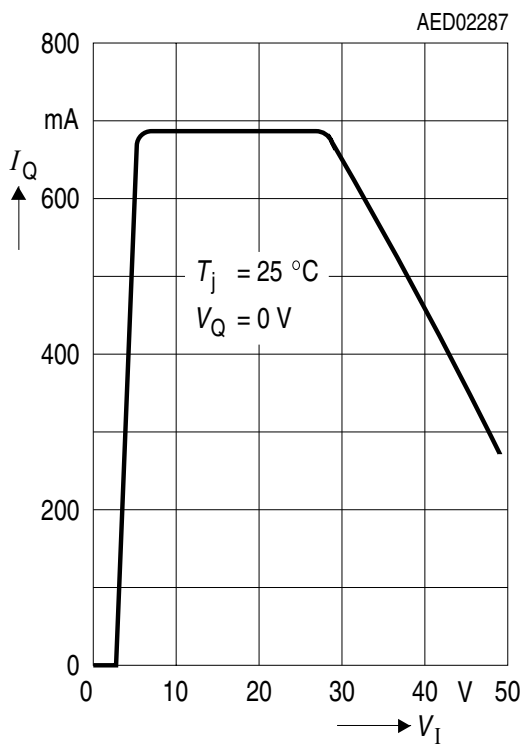

Region of Stability for $C_Q = 10\text{ }\mu\text{F}$

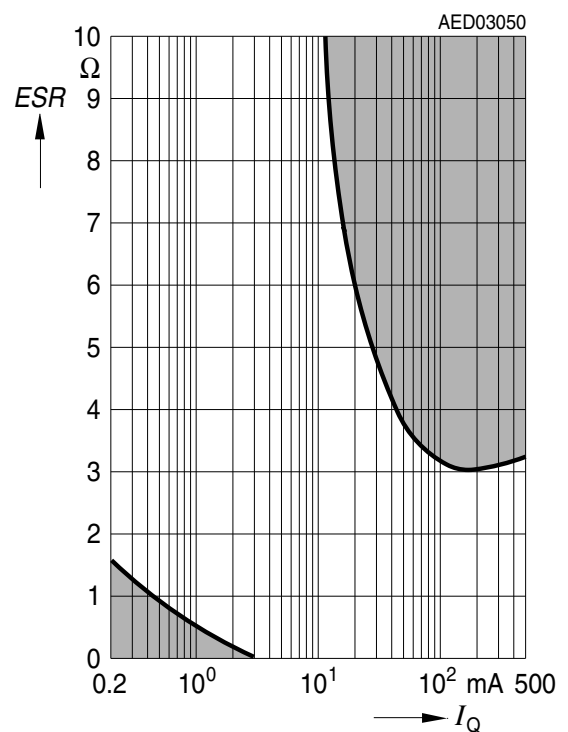

Package Outlines

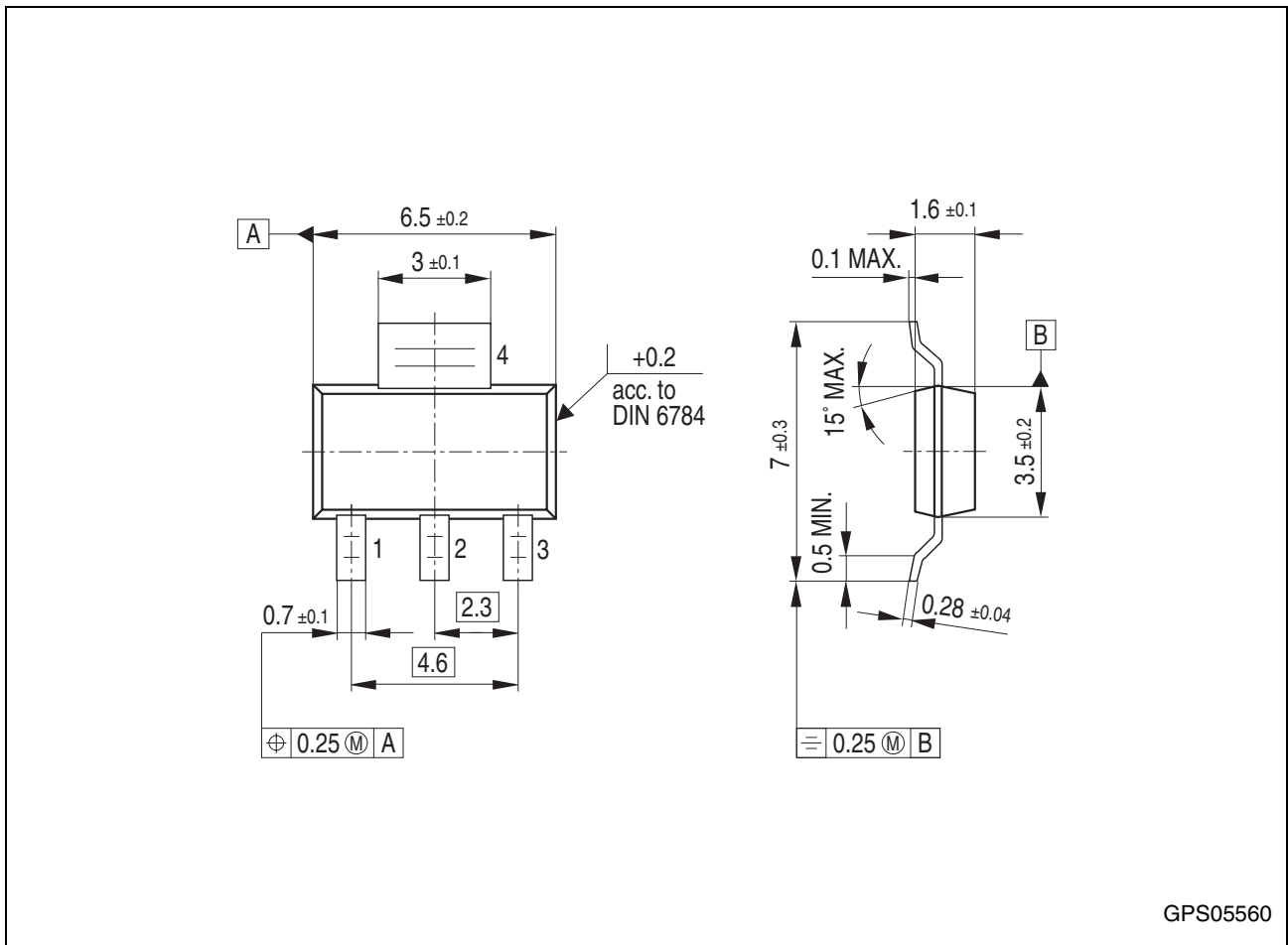

GPS05560

Figure 6 P-SOT223-4-1 (Plastic Small Outline Transistor)

You can find all of our packages, sorts of packing and others in our Infineon Internet Page “Products”: <http://www.infineon.com/products>.

SMD = Surface Mounted Device

Dimensions in mm

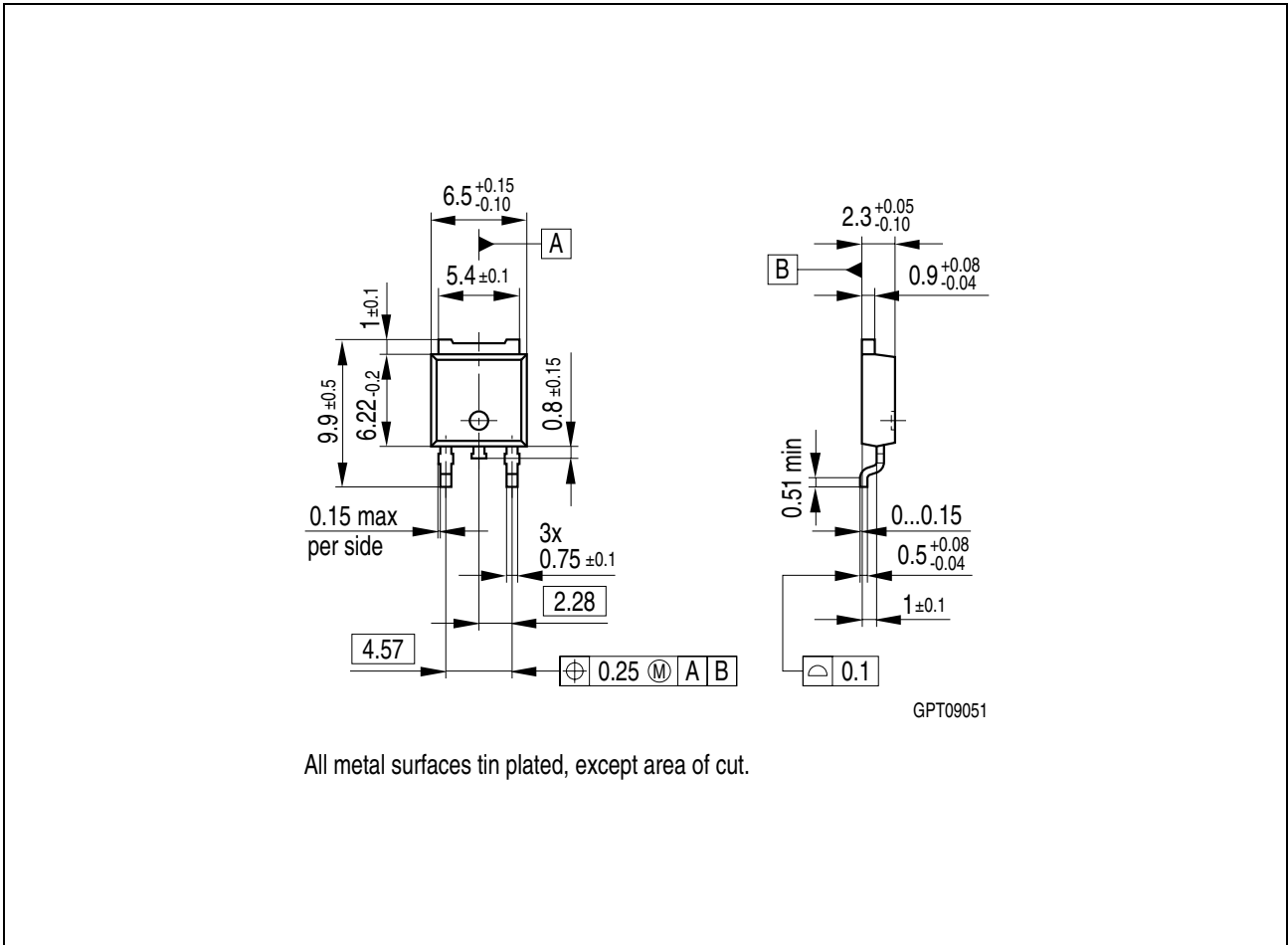

Figure 7 P-TO252-3-1 (Plastic Transistor Single Outline)

You can find all of our packages, sorts of packing and others in our Infineon Internet Page "Products": <http://www.infineon.com/products>.

SMD = Surface Mounted Device

Dimensions in mm

Edition 2004-01-01

**Published by Infineon Technologies AG,
St.-Martin-Strasse 53,
81669 München, Germany**

**© Infineon Technologies AG 2004.
All Rights Reserved.**

Attention please!

The information herein is given to describe certain components and shall not be considered as a guarantee of characteristics.

Terms of delivery and rights to technical change reserved.

We hereby disclaim any and all warranties, including but not limited to warranties of non-infringement, regarding circuits, descriptions and charts stated herein.

Information

For further information on technology, delivery terms and conditions and prices please contact your nearest Infineon Technologies Office (www.infineon.com).

Warnings

Due to technical requirements components may contain dangerous substances. For information on the types in question please contact your nearest Infineon Technologies Office.

Infineon Technologies Components may only be used in life-support devices or systems with the express written approval of Infineon Technologies, if a failure of such components can reasonably be expected to cause the failure of that life-support device or system, or to affect the safety or effectiveness of that device or system. Life support devices or systems are intended to be implanted in the human body, or to support and/or maintain and sustain and/or protect human life. If they fail, it is reasonable to assume that the health of the user or other persons may be endangered.