



Is Now Part of



**ON Semiconductor®**

To learn more about ON Semiconductor, please visit our website at  
[www.onsemi.com](http://www.onsemi.com)

Please note: As part of the Fairchild Semiconductor integration, some of the Fairchild orderable part numbers will need to change in order to meet ON Semiconductor's system requirements. Since the ON Semiconductor product management systems do not have the ability to manage part nomenclature that utilizes an underscore (\_), the underscore (\_) in the Fairchild part numbers will be changed to a dash (-). This document may contain device numbers with an underscore (\_). Please check the ON Semiconductor website to verify the updated device numbers. The most current and up-to-date ordering information can be found at [www.onsemi.com](http://www.onsemi.com). Please email any questions regarding the system integration to [Fairchild\\_questions@onsemi.com](mailto:Fairchild_questions@onsemi.com).

ON Semiconductor and the ON Semiconductor logo are trademarks of Semiconductor Components Industries, LLC dba ON Semiconductor or its subsidiaries in the United States and/or other countries. ON Semiconductor owns the rights to a number of patents, trademarks, copyrights, trade secrets, and other intellectual property. A listing of ON Semiconductor's product/patent coverage may be accessed at [www.onsemi.com/site/pdf/Patent-Marking.pdf](http://www.onsemi.com/site/pdf/Patent-Marking.pdf). ON Semiconductor reserves the right to make changes without further notice to any products herein. ON Semiconductor makes no warranty, representation or guarantee regarding the suitability of its products for any particular purpose, nor does ON Semiconductor assume any liability arising out of the application or use of any product or circuit, and specifically disclaims any and all liability, including without limitation special, consequential or incidental damages. Buyer is responsible for its products and applications using ON Semiconductor products, including compliance with all laws, regulations and safety requirements or standards, regardless of any support or applications information provided by ON Semiconductor. "Typical" parameters which may be provided in ON Semiconductor data sheets and/or specifications can and do vary in different applications and actual performance may vary over time. All operating parameters, including "Typicals" must be validated for each customer application by customer's technical experts. ON Semiconductor does not convey any license under its patent rights nor the rights of others. ON Semiconductor products are not designed, intended, or authorized for use as a critical component in life support systems or any FDA Class 3 medical devices or medical devices with a same or similar classification in a foreign jurisdiction or any devices intended for implantation in the human body. Should Buyer purchase or use ON Semiconductor products for any such unintended or unauthorized application, Buyer shall indemnify and hold ON Semiconductor and its officers, employees, subsidiaries, affiliates, and distributors harmless against all claims, costs, damages, and expenses, and reasonable attorney fees arising out of, directly or indirectly, any claim of personal injury or death associated with such unintended or unauthorized use, even if such claim alleges that ON Semiconductor was negligent regarding the design or manufacture of the part. ON Semiconductor is an Equal Opportunity/Affirmative Action Employer. This literature is subject to all applicable copyright laws and is not for resale in any manner.



# FSA4157, FSA4157A

## Low-Voltage, 1 Ω SPDT Analog Switch

### Features

- FSA4157A Features Lower  $I_{CC}$  when the S Input is Lower Than  $V_{CC}$
- Maximum 1.15 Ω On Resistance ( $R_{ON}$ ) at 4.5 V  $V_{CC}$
- 0.3 Ω Maximum  $R_{ON}$  Flatness at 4.5 V  $V_{CC}$
- Space-Saving 6-lead, MicroPak™ and SC70 6 Packages
- Broad  $V_{CC}$  Operating Range:
  - FSA4157: 1.65 V to 5.5 V
  - FSA4157A: 2.7 V to 5.5 V
- Fast Turn-On and Turn-Off Time
- Break-Before-Make Enable Circuitry
- Over-Voltage Tolerant TTL-Compatible Control Circuitry

### Description

FSA4157 and FSA4157A are high performance Single Pole/Double Throw (SPDT) analog switches. Both devices feature ultra low  $R_{ON}$  of 1.15 Ω maximum at 4.5 V  $V_{CC}$  and operates over the wide  $V_{CC}$  range of 1.65 V to 5.5 V for FSA4157, and 2.7 V to 5.5 V for FSA4157A. The device is fabricated with sub-micron CMOS technology to achieve fast switching speeds and is designed for break-before-make operation. The select input is TTL level compatible.

The FSA4157A features very low quiescent current even when the control voltage is lower than the  $V_{CC}$  supply. This feature services the mobile handset applications very well allowing for the direct interface with baseband processor general purpose I/Os.

### Ordering Information

Part Number	Top Mark	Package Description	Packing Method
FSA4157P6X	A57	6-Lead SC70, EIAJ SC88, 1.25 mm Wide	3000 Units Tape and Reel
FSA4157L6X	EG	6-Lead MicroPak,™ 1.0 mm Wide	5000 Units Tape and Reel
FSA4157AP6X	B57	6-Lead SC70, EIAJ SC88, 1.25 mm Wide	3000 Units Tape and Reel
FSA4157AL6X	EU	6-Lead MicroPak™, 1.0 mm Wide	5000 Units Tape and Reel

## Pin Configurations

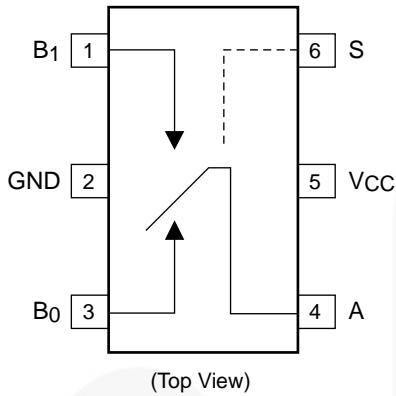


Figure 1. SC70 Pin Assignments

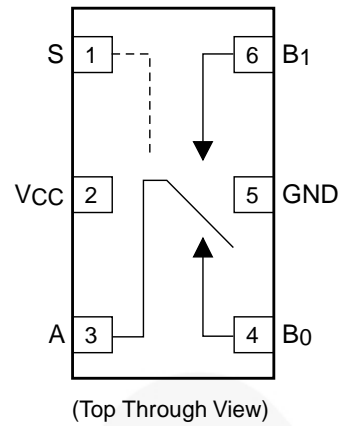


Figure 2. MicroPak™ Pin Assignments

## Pin Definitions

Pin# SC70	Pin# MicroPak™	Name	Description
1	6	B1	Data Ports
2	5	GND	Ground
3	4	B0	Data Ports
4	3	A	Data Ports
5	2	V <sub>CC</sub>	Supply Voltage
6	1	S	Control Input

## Truth Table

Control Input (S)	Function
Low	B0 connected to A
High	B1 connected to A

## Absolute Maximum Ratings

Stresses exceeding the absolute maximum ratings may damage the device. The device may not function or be operable above the recommended operating conditions and stressing the parts to these levels is not recommended. In addition, extended exposure to stresses above the recommended operating conditions may affect device reliability. The absolute maximum ratings are stress ratings only.

Symbol	Parameter		Min.	Max.	Unit
$V_{CC}$	Supply Voltage		-0.5	6.0	V
$V_S$	DC Switch Voltage <sup>(1)</sup>		-0.5	$V_{CC} + 0.5$	V
$V_{IN}$	DC Input Voltage <sup>(1)</sup>		-0.5	6.0	V
$I_{IK}$	DC Input Diode Current		-50		mA
$I_{SW}$	Switch Current			200	mA
$I_{SWPEAK}$	Peak Switch Current (Pulse at 1 ms duration, <10% Duty Cycle)			400	mA
$P_D$	Power Dissipation at 85°C	SC70		180	mW
		MicroPak™			
$T_{STG}$	Storage Temperature Range		-65	+150	°C
$T_J$	Maximum Junction Temperature			+150	°C
$T_L$	Lead Temperature (Soldering, 10 seconds)			+260	°C
ESD	Electrostatic Discharge Capability	Human Body Model, JESD22-A114 (FSA4157A)		7500	V

**Note:**

1. Input and output negative ratings may be exceeded if input and output diode current ratings are observed.

## Recommended Operating Conditions

The Recommended Operating Conditions table defines the conditions for actual device operation. Recommended operating conditions are specified to ensure optimal performance to the datasheet specifications. Fairchild does not recommend exceeding them or designing to Absolute Maximum Ratings.

Symbol	Parameter		Min.	Max.	Unit
$V_{CC}$	Supply Voltage	FSA4157	1.65	5.50	V
		FSA4157A	2.7	5.5	
$V_{CNTRL}$	Control Input Voltage <sup>(2)</sup>		0	$V_{CC}$	V
$V_{SW}$	Switch Input Voltage		0	$V_{CC}$	V
$T_A$	Operating Temperature		-40	+85	°C
$\theta_{JA}$	Thermal Resistance in Still Air	SC70		350	°C/W
		MicroPak™ (Estimated)		330	

**Note:**

2. Control input must be held HIGH or LOW and it must not float.

## DC Electrical Characteristics

Typical values are at 25°C unless otherwise specified.

Symbol	Parameter	Conditions	V <sub>CC</sub> (V)	Ambient Temperature					Unit
				-25°			-40 to +85°C		
				Min.	Typ.	Max.	Min.	Max.	
V <sub>IH</sub>	Input Voltage High	FSA4157 Only	1.8 to 2.7				1.0		V
			2.7 to 3.6				2.0		
			4.5 to 5.5				2.4		
V <sub>IL</sub>	Input Voltage Low	FSA4157 Only	1.8 to 2.7					0.4	V
		FSA4157A Only	2.7 to 3.6					0.4	
			2.7 to 3.6					0.6	
			4.5 to 5.5					0.8	
I <sub>IN</sub>	Control Input Leakage	V <sub>IN</sub> =0 V to V <sub>CC</sub>	2.7 to 3.6				-1.0	1.0	μA
			4.5 to 5.5				-1.0	1.0	
I <sub>NO(OFF)</sub> , I <sub>NC(OFF)</sub>	Off Leakage Current of Port B0 and B1	A=1 V, 4.5 V, B <sub>0</sub> or B <sub>1</sub> =4.5, 1 V	5.5		±2		-20	20	nA
I <sub>A(ON)</sub>	On Leakage Current of Port A	A=1 V, 4.5V, B <sub>0</sub> or B <sub>1</sub> =4.5, 1 V, 4.5 V or Floating	5.5		±4		-40	40	nA
R <sub>ON</sub>	Switch On Resistance	I <sub>OUT</sub> =100 mA, B <sub>0</sub> or B <sub>1</sub> =1.5 V	2.7		2.6	4.0		4.3	Ω
		I <sub>OUT</sub> =100mA, B <sub>0</sub> or B <sub>1</sub> =3.5V	4.5		0.95	1.15		1.30	
ΔR <sub>ON</sub>	On Resistance Matching Between Channels <sup>(4)</sup>	I <sub>OUT</sub> =100 mA, B <sub>0</sub> or B <sub>1</sub> =1.5 V	4.5		0.06	0.12		0.15	Ω
R <sub>FLAT(ON)</sub>	On Resistance Flatness <sup>(4)</sup>	I <sub>OUT</sub> =100 mA, B <sub>0</sub> or B <sub>1</sub> =0 V, 0.75 V, 1.5 V	2.7		1.4				Ω
		I <sub>OUT</sub> =100 mA, B <sub>0</sub> or B <sub>1</sub> =0 V, 1 V, 2 V	4.5		0.2	0.3		0.4	
I <sub>CC</sub>	Quiescent Supply Current	V <sub>IN</sub> =0 V or V <sub>CC</sub> , I <sub>OUT</sub> =0 V	3.6		0.1	0.5		1.0	μA
			5.5		0.1	0.5		1.0	
ΔI <sub>CC</sub>	Increase in I <sub>CC</sub> per Input	One Input at 2.7 V, others at V <sub>CC</sub> or GND (FSA4157A Only)	4.3		0.2			10.0	μA

### Notes:

- Measured by the voltage drop between the A and B pins at the indicated current through the switch. On resistance is determined by the lower of the voltage on the two (A or B ports).
- ΔR<sub>ON</sub> = R<sub>ON max</sub> – R<sub>ON min</sub> measured at identical V<sub>CC</sub>, temperature, and voltage.
- Flatness is defined as the difference between the maximum and minimum value of on resistance over the specified range of conditions.

## AC Electrical Characteristics

Typical values are at 25°C unless otherwise specified.

Symbol	Parameter	Conditions	V <sub>CC</sub> (V)	Ambient Temperature					Unit	Figure
				-25°			-40 to +85°C			
				Min.	Typ.	Max.	Min.	Max.		
t <sub>ON</sub>	Turn-On Time	B <sub>0</sub> or B <sub>1</sub> =1.5 V, R <sub>L</sub> =50 $\Omega$ , C <sub>L</sub> =35 pF (FSA4157A Only)	2.7 to 3.6			60		65	ns	Figure 8
		B <sub>0</sub> or B <sub>1</sub> =1.5 V, R <sub>L</sub> =50 $\Omega$ , C <sub>L</sub> =35pF	2.7 to 3.6			50		60		
		B <sub>0</sub> or B <sub>1</sub> =1.5 V, R <sub>L</sub> =50 $\Omega$ , C <sub>L</sub> =35pF	4.5 to 5.5			35		40		
t <sub>OFF</sub>	Turn-Off Time	B <sub>0</sub> or B <sub>1</sub> =1.5 V, R <sub>L</sub> =50 $\Omega$ , C <sub>L</sub> =35 pF	2.7 to 3.6			20		30	ns	Figure 8
		B <sub>0</sub> or B <sub>1</sub> =1.5 V, R <sub>L</sub> =50 $\Omega$ , C <sub>L</sub> =35 pF	4.5 to 5.5			15		20		
t <sub>BBM</sub>	Break-Before-Make Time	FSA4157	2.7 to 3.6						ns	Figure 9
			4.5 to 5.5		20					
		FSA4157A Only	4.5 to 5.5		25					
Q	Charge Injection	C <sub>L</sub> =1.0 nF, V <sub>GE</sub> =0 V, R <sub>GEN</sub> =0 $\Omega$	2.7 to 3.6		10			pC	Figure 11	
			4.5 to 5.5		20					
OIRR	Off Isolation	f=1 MHz, R <sub>L</sub> =50 $\Omega$	2.7 to 3.6		-70			dB	Figure 10	
			4.5 to 5.5		-70					
Xtalk	Crosstalk	f=1 MHz, R <sub>L</sub> =50 $\Omega$	2.7 to 3.6		-70			dB	Figure 10	
			4.5 to 5.5		-70					
BW	-3db Bandwidth	R <sub>L</sub> =50 $\Omega$	2.7 to 3.6			300		MHz	Figure 13	
			4.5 to 5.5			300				
THD	Total Harmonic Distortion	R <sub>L</sub> =600 $\Omega$ , V <sub>IN</sub> =0.5, f=20 Hz to 20 kHz	2.7 to 3.6		0.002			%	Figure 14	
			4.5 to 5.5		0.002					

## Capacitance

Symbol	Parameter	Conditions	V <sub>CC</sub> (V)	Ambient Temperature			Unit	Figure
				-25°				
				Min.	Typ.	Max.		
C <sub>IN</sub>	Control Pin Input Capacitance	f=1 MHz	0		3.5		pF	Figure 12
C <sub>OFF</sub>	B Port Off Capacitance	f=1 MHz	4.5		12.0		pF	Figure 12
C <sub>ON</sub>	On Capacitance	f=1 MHz	4.5		40.0		pF	Figure 12

Typical Performance Characteristics

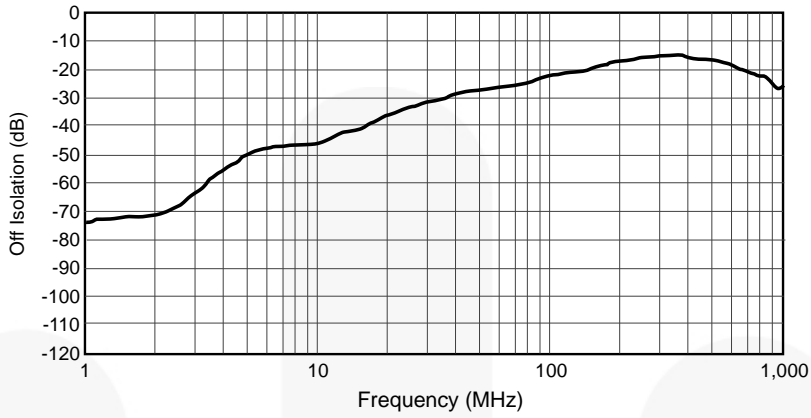


Figure 3. Off Isolation,  $V_{CC} = 2.7\text{ V to }5.5\text{ V}$

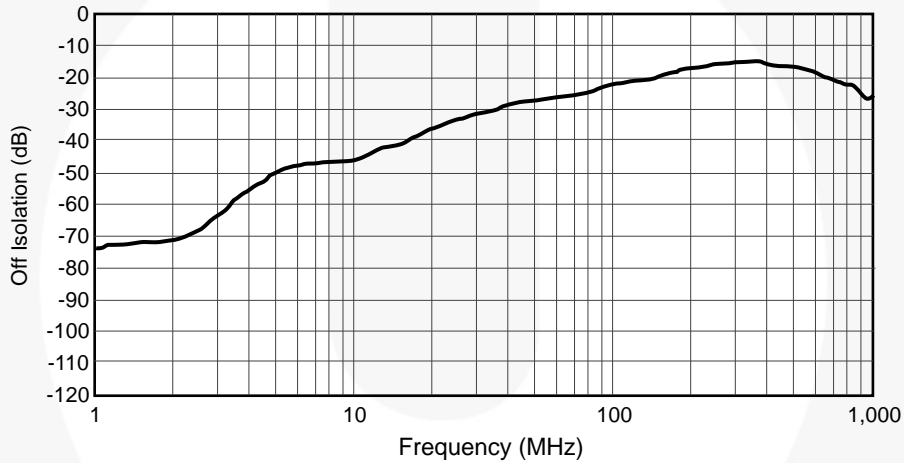


Figure 4. Crosstalk,  $V_{CC} = 2.7\text{ V to }5.5\text{ V}$

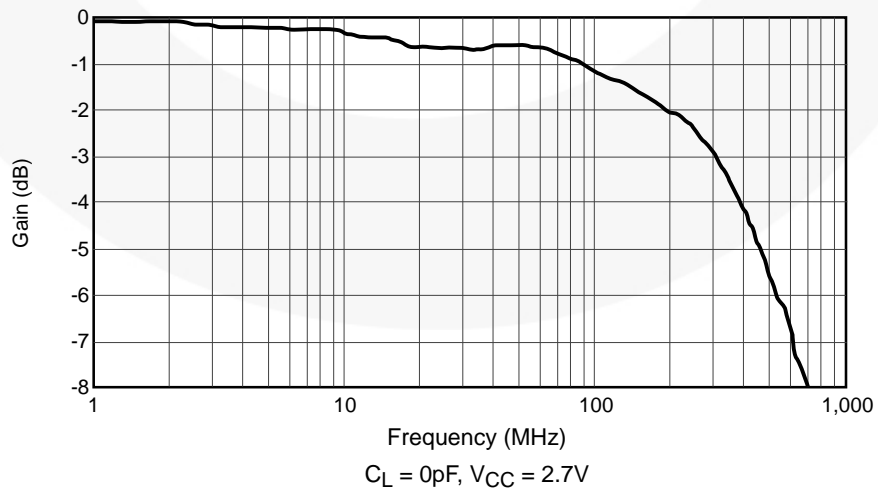
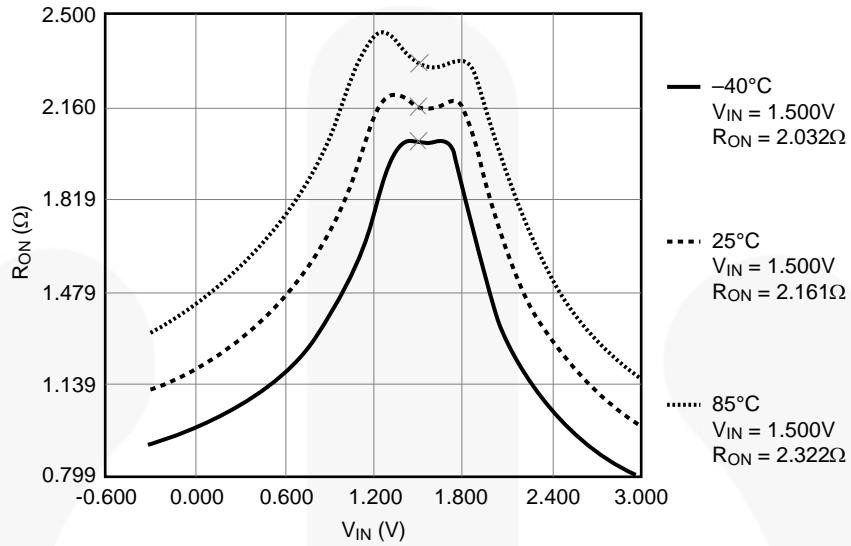
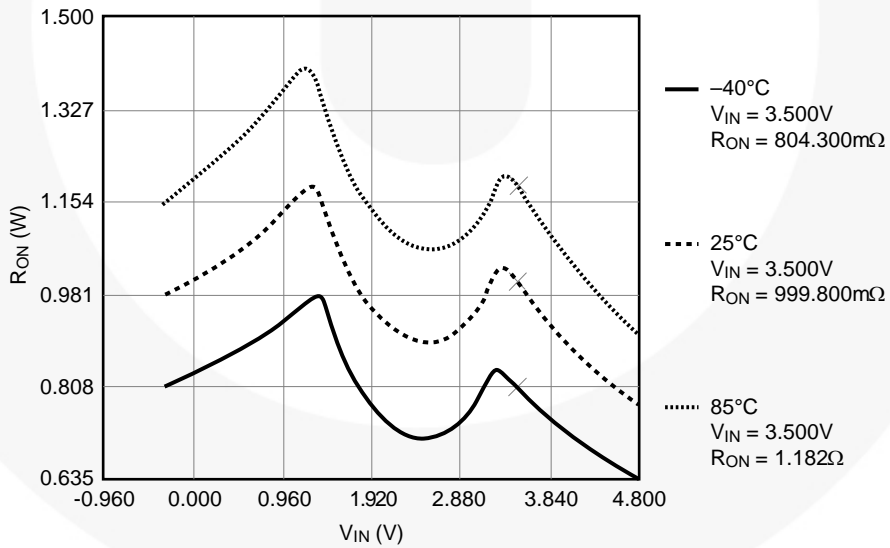


Figure 5. Bandwidth,  $V_{CC} = 2.7\text{ V to }5.5\text{ V}$   
 $C_L = 0\text{ pF}, V_{CC} = 2.7\text{ V}$

**Typical Performance Characteristics** (Continued)



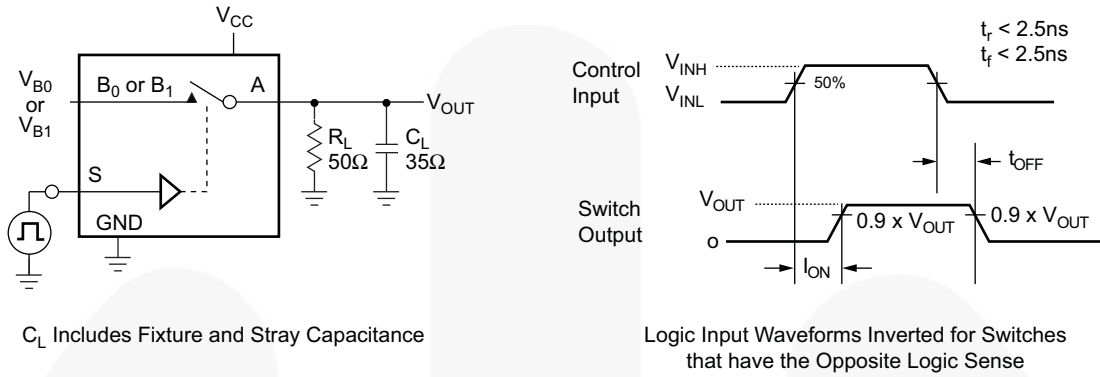
**Figure 6.** RON Switch On Resistance, ION = 100 mA, VCC = 2.7



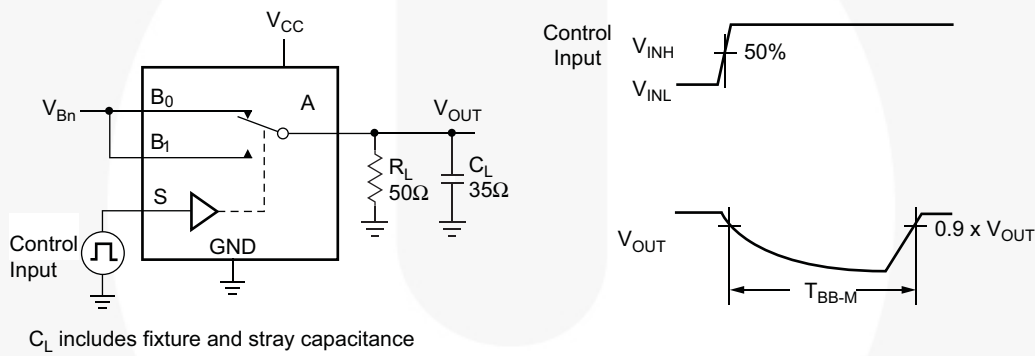
**Figure 7.** RON Switch On Resistance, ION = 100 mA, VCC = 4.5 V



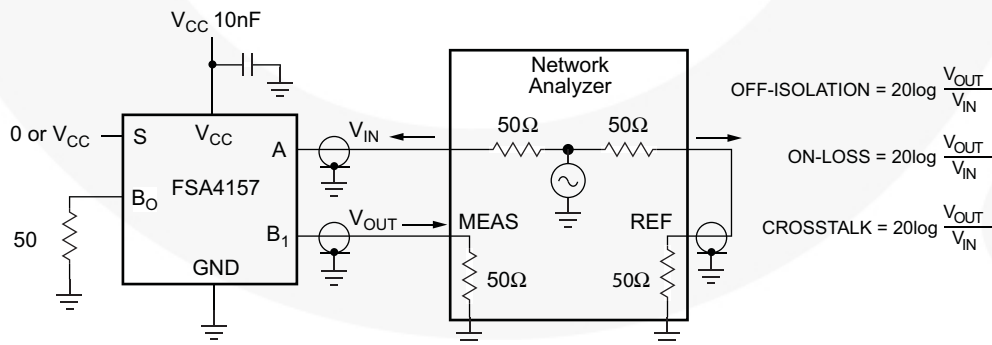
## AC Loadings and Waveforms



**Figure 8. Turn On / Off Timing**

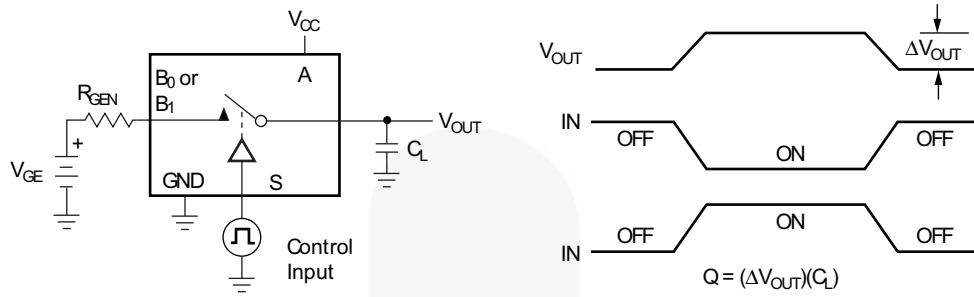


**Figure 9. Break Before Make Timing**

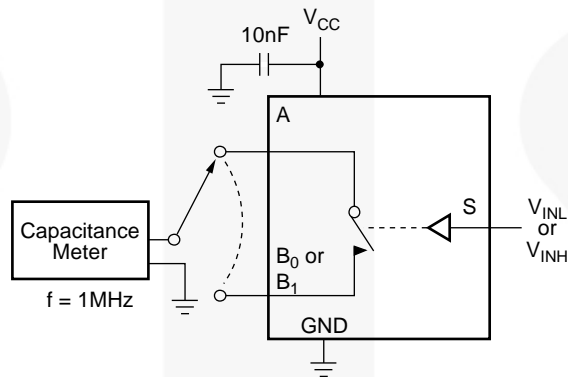


**Figure 10. Off Isolation and Crosstalk**

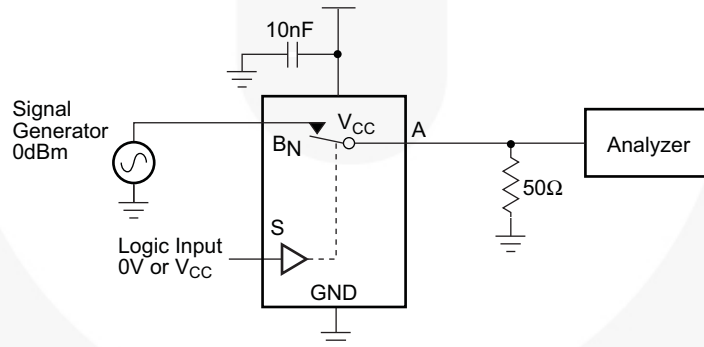
**AC Loadings and Waveforms (Continued)**



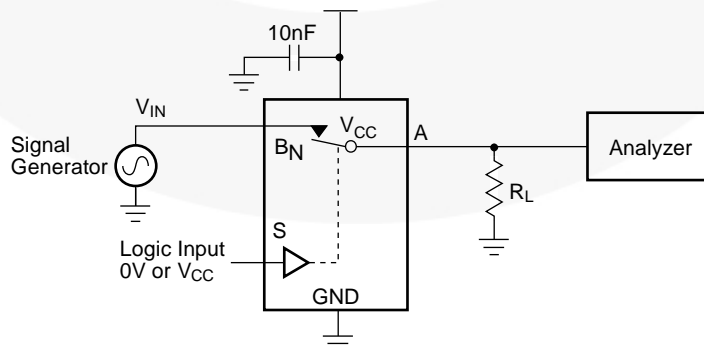
**Figure 11. Charge Injection**



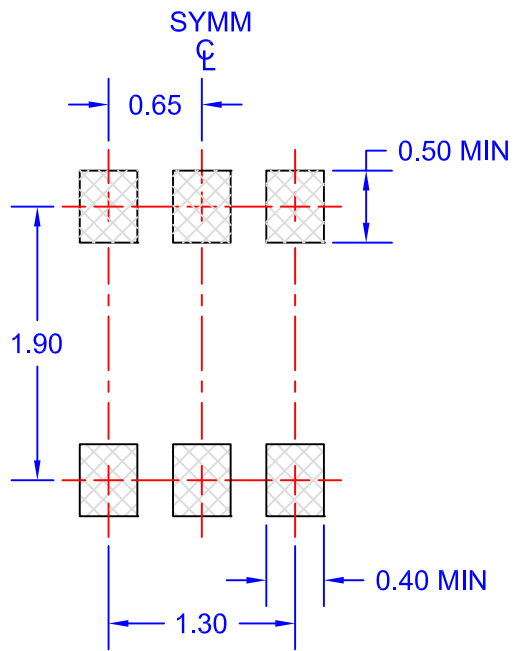
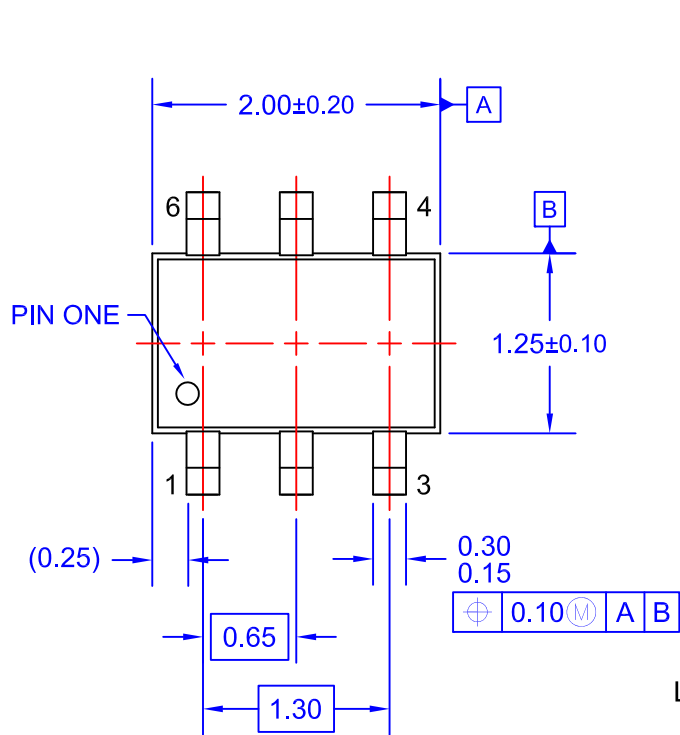
**Figure 12. On / Off Capacitance Measurement Setup**



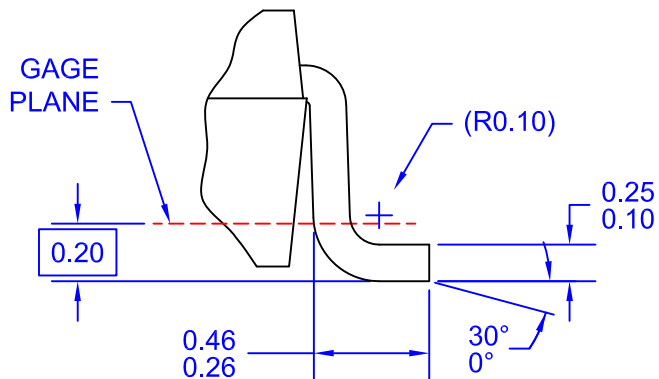
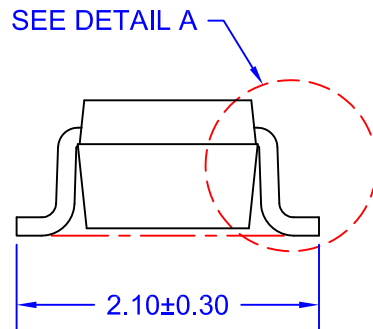
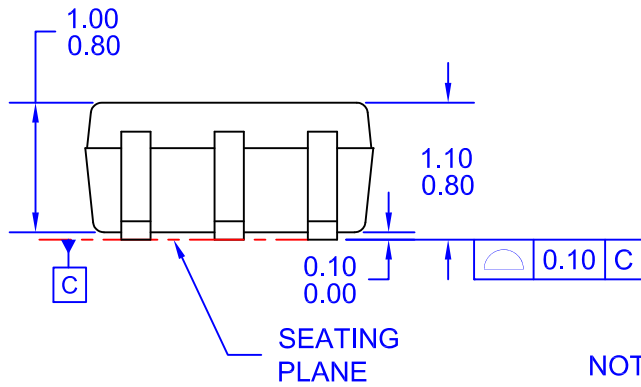
**Figure 13. Bandwidth**



**Figure 14. Harmonic Distortion**



LAND PATTERN RECOMMENDATION



DETAIL A  
SCALE: 60X

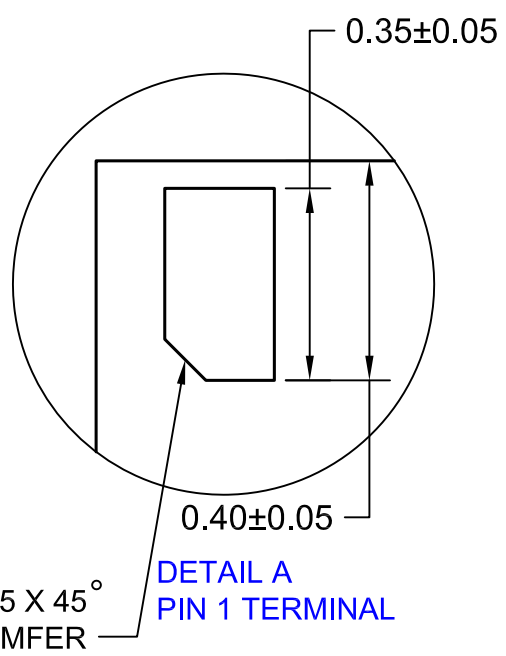
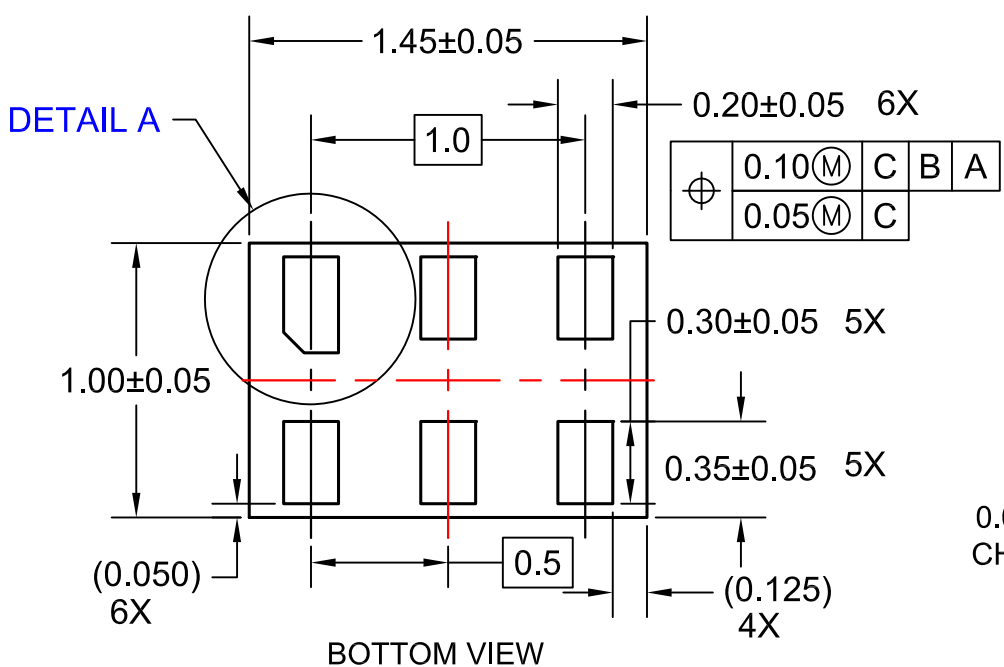
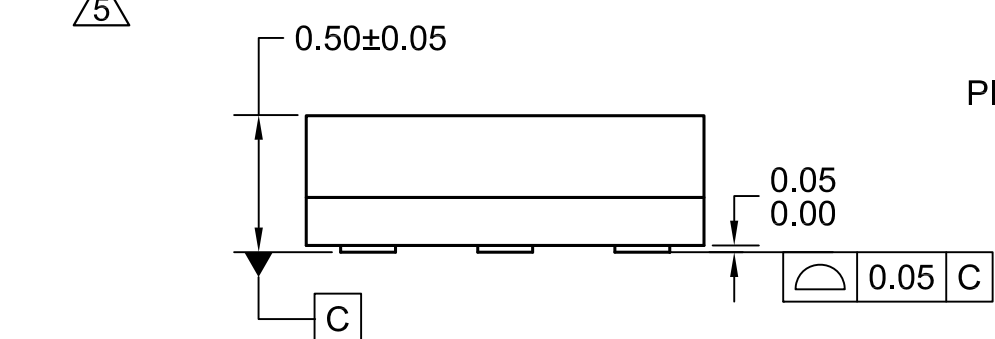
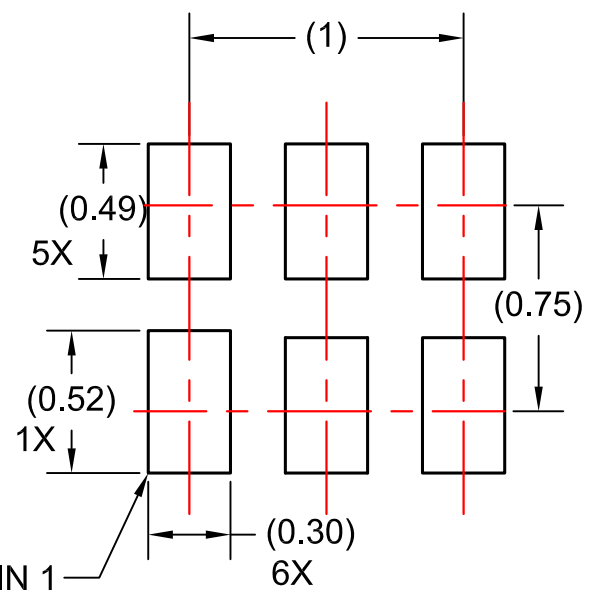
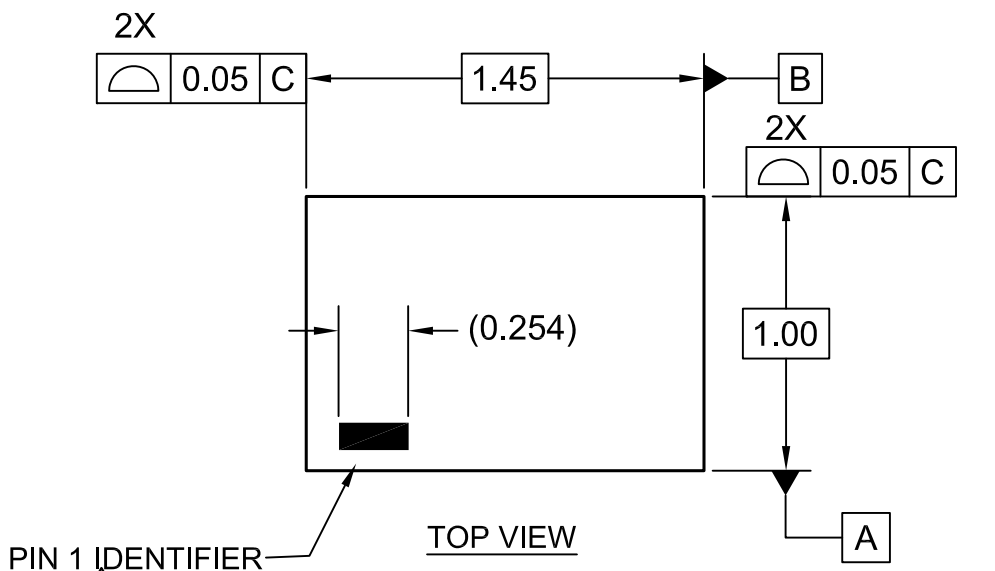
NOTES: UNLESS OTHERWISE SPECIFIED  
A) THIS PACKAGE CONFORMS TO EIAJ SC-88, 1996.

B) ALL DIMENSIONS ARE IN MILLIMETERS.  
C) DIMENSIONS DO NOT INCLUDE BURRS OR MOLD FLASH.

D) DIMENSIONING AND TOLERANCING PER ASME Y14.5M-2009

E) DRAWING FILENAME: MKT-MAA06AREV7






NOTES:

1. CONFORMS TO JEDEC STANDARD MO-252 VARIATION UAAD
2. DIMENSIONS ARE IN MILLIMETERS
3. DRAWING CONFORMS TO ASME Y14.5M-2009
4. LANDPATTERN RECOMMENDATION PER FSC
5. PIN ONE IDENTIFIER IS 2X LENGTH OF ANY OTHER LINE IN THE MARK CODE LAYOUT.
6. FILENAME AND REVISION: MAC06AREV6



ON Semiconductor and  are trademarks of Semiconductor Components Industries, LLC dba ON Semiconductor or its subsidiaries in the United States and/or other countries. ON Semiconductor owns the rights to a number of patents, trademarks, copyrights, trade secrets, and other intellectual property. A listing of ON Semiconductor's product/patent coverage may be accessed at [www.onsemi.com/site/pdf/Patent-Marking.pdf](http://www.onsemi.com/site/pdf/Patent-Marking.pdf). ON Semiconductor reserves the right to make changes without further notice to any products herein. ON Semiconductor makes no warranty, representation or guarantee regarding the suitability of its products for any particular purpose, nor does ON Semiconductor assume any liability arising out of the application or use of any product or circuit, and specifically disclaims any and all liability, including without limitation special, consequential or incidental damages. Buyer is responsible for its products and applications using ON Semiconductor products, including compliance with all laws, regulations and safety requirements or standards, regardless of any support or applications information provided by ON Semiconductor. "Typical" parameters which may be provided in ON Semiconductor data sheets and/or specifications can and do vary in different applications and actual performance may vary over time. All operating parameters, including "Typicals" must be validated for each customer application by customer's technical experts. ON Semiconductor does not convey any license under its patent rights nor the rights of others. ON Semiconductor products are not designed, intended, or authorized for use as a critical component in life support systems or any FDA Class 3 medical devices or medical devices with a same or similar classification in a foreign jurisdiction or any devices intended for implantation in the human body. Should Buyer purchase or use ON Semiconductor products for any such unintended or unauthorized application, Buyer shall indemnify and hold ON Semiconductor and its officers, employees, subsidiaries, affiliates, and distributors harmless against all claims, costs, damages, and expenses, and reasonable attorney fees arising out of, directly or indirectly, any claim of personal injury or death associated with such unintended or unauthorized use, even if such claim alleges that ON Semiconductor was negligent regarding the design or manufacture of the part. ON Semiconductor is an Equal Opportunity/Affirmative Action Employer. This literature is subject to all applicable copyright laws and is not for resale in any manner.

## PUBLICATION ORDERING INFORMATION

### LITERATURE FULFILLMENT:

Literature Distribution Center for ON Semiconductor  
19521 E. 32nd Pkwy, Aurora, Colorado 80011 USA  
**Phone:** 303-675-2175 or 800-344-3860 Toll Free USA/Canada  
**Fax:** 303-675-2176 or 800-344-3867 Toll Free USA/Canada  
**Email:** [orderlit@onsemi.com](mailto:orderlit@onsemi.com)

**N. American Technical Support:** 800-282-9855 Toll Free  
USA/Canada  
**Europe, Middle East and Africa Technical Support:**  
Phone: 421 33 790 2910  
**Japan Customer Focus Center**  
Phone: 81-3-5817-1050

**ON Semiconductor Website:** [www.onsemi.com](http://www.onsemi.com)  
**Order Literature:** <http://www.onsemi.com/orderlit>  
For additional information, please contact your local  
Sales Representative