

TPS63070 2-V to 16-V Buck-Boost Converter With 3.6-A Switch Current

1 Features

- Input Voltage Range: 2.0 V to 16 V
- Output Voltage Range: 2.5 V to 9 V
- Up to 95% Efficiency
- +/- 1% dc accuracy in PWM mode
- +3% / -1% dc accuracy in PFM mode
- 2 A Output Current in Buck Mode
- 2 A Output Current in Boost Mode (VIN = 4 V; Vout = 5 V)
- Precise ENABLE input allows
 - user defined undervoltage lockout
 - exact sequencing
- Automatic Transition Between Step Down and Boost Mode
- Typical Device Quiescent Current: 50 μ A
- Fixed and Adjustable Output Voltage Options
- Power Save Mode for Improved Efficiency at Low Output Power
- Forced Fixed Frequency Operation at 2.4 MHz and Synchronization Option
- Power Good Output
- VSEL simply allows output voltage change
- Load Disconnect During Shutdown
- Overtemperature Protection
- Input / Output Overvoltage Protection
- Available in QFN Package

2 Applications

- Dual LI-Ion Applications
- Industrial Metering Equipment
- DSC's and Camcorders
- Notebook Computers
- Ultra Mobile PC's and Mobile Internet Devices
- Personal Medical Products

3 Description

The TPS6307x is a high efficiency, low quiescent current buck-boost converter suitable for applications where the input voltage can be higher or lower than the output voltage. Output currents can go as high as 2 A in boost mode and in buck mode. The buck-boost converter is based on a fixed frequency, pulse-width-modulation (PWM) controller using synchronous rectification to obtain maximum efficiency. At low load currents, the converter enters Power Save Mode to maintain high efficiency over a wide load current range. The converter can be disabled to minimize battery drain. During shutdown, the load is disconnected from the battery. The device is available in a 2.5 mm x 3 mm QFN package.

Device Information⁽¹⁾

PART NUMBER	PACKAGE	BODY SIZE (NOM)
TPS63070	VQFN	2.5 mm x 3 mm
TPS630701	VQFN	2.5 mm x 3 mm

(1) For all available packages, see the orderable addendum at the end of the datasheet.

Simplified Schematic

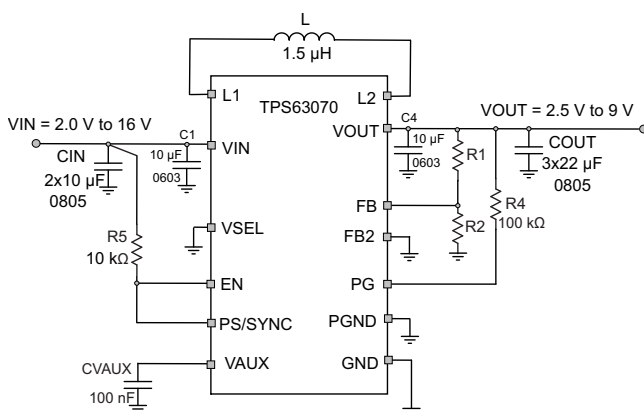

Efficiency vs Output Current; Vo = 5 V

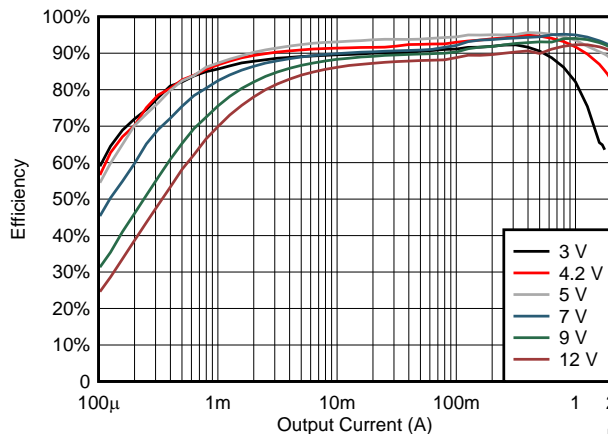

Table of Contents

1	Features	1	9	Application and Implementation	16
2	Applications	1	9.1	Application Information.....	16
3	Description	1	9.2	Typical Application for adjustable version	16
4	Revision History	2	9.3	Typical Application for Fixed Voltage Version	24
5	Device Comparison Table	3	10	Power Supply Recommendations	28
6	Pin Configuration and Functions	3	10.1	Thermal Information	28
7	Specifications	4	11	Layout	29
7.1	Absolute Maximum Ratings	4	11.1	Layout Guidelines	29
7.2	ESD Ratings	4	11.2	Layout Example	29
7.3	Recommended Operating Conditions.....	4	12	Device and Documentation Support	30
7.4	Thermal Information	5	12.1	Device Support	30
7.5	Electrical Characteristics.....	6	12.2	Related Links	30
7.6	Typical Characteristics.....	8	12.3	Receiving Notification of Documentation Updates	30
8	Detailed Description	9	12.4	Community Resources.....	30
8.1	Overview	9	12.5	Trademarks	30
8.2	Functional Block Diagram TPS63070	9	12.6	Electrostatic Discharge Caution.....	30
8.3	Functional Block Diagram TPS630701	10	12.7	Glossary	30
8.4	Feature Description.....	10	13	Mechanical, Packaging, and Orderable Information	31
8.5	Device Functional Modes.....	14			

4 Revision History

Changes from Original (June 2016) to Revision A	Page
• Added full Production Data	1

5 Device Comparison Table

Device Number	Features	Output Voltage	Marking
TPS63070	output discharge = off	adjustable	3070
TPS630701	output discharge = off	fixed 5 V	0701

6 Pin Configuration and Functions

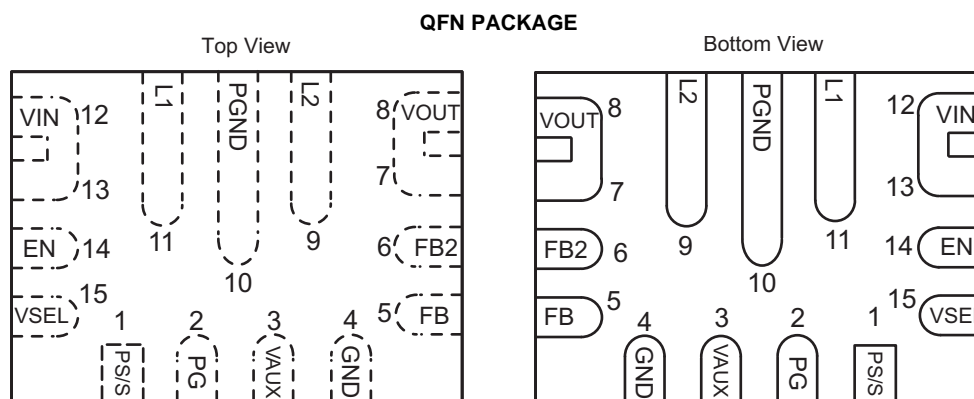

Pin Functions

PIN		I/O	DESCRIPTION
NAME	NO.		
EN	14	I	Enable input. Pull high to enable the device, pull low to disable the device.
FB	5	I	Voltage feedback of adjustable versions, must be connected to VOUT on fixed output voltage versions
GND	4		Control / logic ground
L1	11	I	Connection for Inductor
L2	9	I	Connection for Inductor
PS/SYNC	1	I	Pull to low for forced PWM, pull high for PWM/PFM (power save) mode. Apply a clock signal to synchronize to an external frequency.
PG	2	O	Open drain power good output
PGND	10		Power ground
VIN	12, 13	I	Supply voltage for power stage
VOUT	7,8	O	Buck-boost converter output
VAUX	3	O	Connection for Capacitor of internal voltage regulator. This pin must not be loaded externally.
VSEL	15	I	Voltage scaling input. A high level on this pin enables a transistor which pulls pin FB2 to GND.
FB2	6	O	Voltage scaling output. Connect a resistor from FB to FB2 to change the voltage divider ratio on the feedback pin. A logic high level on VSEL will change the output voltage to a higher value. Leave the pin open or connect to GND if not used.

7 Specifications

7.1 Absolute Maximum Ratings

over operating free-air temperature range (unless otherwise noted) ⁽¹⁾

		MIN	MAX	UNIT
Voltage range	VIN, PS/SYNC, EN, VSEL	-0.3	20	V
	L1	-0.3	20	V
	L2, PG, VOUT, FB	-0.3	12	V
	AUX	-0.3	7	V
	FB2	-0.3	3	V
Operating junction temperature, T _j		-40	150	°C
Storage temperature range, T _{stg}		-65	150	°C

- (1) Stresses beyond those listed under *Absolute Maximum Ratings* may cause permanent damage to the device. These are stress ratings only, which do not imply functional operation of the device at these or any other conditions beyond those indicated under *Recommended Operating Conditions*. Exposure to absolute-maximum-rated conditions for extended periods may affect device reliability.

7.2 ESD Ratings

			VALUE	UNIT
V _(ESD)	Electrostatic discharge	Human body model (HBM), per ANSI/ESDA/JEDEC JS-001, all pins ⁽¹⁾	±2000	V
		Charged device model (CDM), per JEDEC specification JESD22-C101, all pins ⁽²⁾	±500	

- (1) JEDEC document JEP155 states that 500-V HBM allows safe manufacturing with a standard ESD control process.
 (2) JEDEC document JEP157 states that 250-V CDM allows safe manufacturing with a standard ESD control process.

7.3 Recommended Operating Conditions

over operating free-air temperature range (unless otherwise noted)

	MIN	NOM	MAX	UNIT
Supply voltage at VIN	2.0		16	V
Output Voltage	2.5		9	V
Output Current IOU _T			2	A
Effective Inductance	0.7	1.5	2.8	μH
Capacitance connected to VIN pin	4.7	10		μF
Capacitance connected to VAUX pin		100		nF
Total capacitance connected to VOUT pin ⁽¹⁾	15	47	470	μF
Operating junction temperature range, T _J	-40		125	°C

- (1) Due to the dc bias effect of ceramic capacitors, the effective capacitance is lower than the nominal value when a voltage is applied. This is why the capacitance is specified to allow the selection of the minimal capacitor required with the dc bias effect for this type of capacitor in mind. The capacitance range given above is for the nominal inductance of 1.5 μH. Please also see the detailed design procedure in the application section about the ratio of inductance and minimum output capacitance.

7.4 Thermal Information

THERMAL METRIC ⁽¹⁾		TPS63070x	UNIT
		VQFN	
		13 PINS	
$R_{\theta JA}$	Junction-to-ambient thermal resistance	63	°C/W
$R_{\theta JC(top)}$	Junction-to-case (top) thermal resistance	42	°C/W
$R_{\theta JB}$	Junction-to-board thermal resistance	13	°C/W
Ψ_{JT}	Junction-to-top characterization parameter	2.4	°C/W
Ψ_{JB}	Junction-to-board characterization parameter	13	°C/W
$R_{\theta JC(bot)}$	Junction-to-case (bottom) thermal resistance	n/a	°C/W

(1) For more information about traditional and new thermal metrics, see the *IC Package Thermal Metrics* application report, [SPRA953](#).

7.5 Electrical Characteristics

over VIN = 2V to 16V; Tj = -40°C to 125°C; typical values are at Tj = 25°C (unless otherwise noted)

PARAMETER		TEST CONDITIONS	MIN	TYP	MAX	UNIT
SUPPLY						
VIN	Input voltage range	once started; Vout ≥ 3.0 V	2.0		16	V
VIN	Input voltage range	for start-up; Vout < 3.0 V	3.0		16	V
IOUT	Output current	during operation with either VIN ≥ 4.5 V or VOUT ≥ 4.5 V and the boost factor (VOUT/VIN) ≤ 1			2	A
IQ	Quiescent current	into VIN; IOUT= 0 mA, VEN = VIN = 6 V, PFM VOUT = 5 V; Tj = -40°C to 85°C		54	103	μA
IQ	Quiescent current	into VIN; IOUT= 0 mA, VEN = VIN = 6 V, PFM VOUT = 5 V; Tj = -40°C to 125°C			133	μA
IQ	Quiescent current	into VOUT; IOUT= 0 mA, VEN = VIN = 6 V, VOUT = 5 V, PFM Tj = -40°C to 85°C		5	9	μA
IQ	Quiescent current	into VOUT; IOUT= 0 mA, VEN = VIN = 6 V, VOUT = 5 V, PFM Tj = -40°C to 125°C			17	μA
ISD	Shutdown current	VEN = 0 V; Tj = -40°C to 85°C; VIN = 5V		2	12	μA
ISD	Shutdown current	VEN = 0 V; Tj = -40°C to 85°C			26	μA
VUVLO	Undervoltage lockout threshold	VIN voltage falling	1.7	1.85	1.95	V
VUVLO,TH	Undervoltage lockout hysteresis	VIN voltage rising	525	850		mV
TSD	Thermal shutdown			160		°C
TSD	Thermal shutdown hysteresis			20		°C
LOGIC SIGNALS: EN, PS/SYNC, PG, VSEL						
VTHR	Threshold Voltage rising edge for EN pin and PS/SYNC used for PWM/PFM mode change		0.77	0.8	0.83	V
VTHF	Threshold Voltage falling edge for EN pin and PS/SYNC used for PWM/PFM mode change		0.67	0.7	0.73	V
VIL	VSEL low level input voltage; PS/SYNC low level input voltage when used for synchronization				0.3	V
VIH	VSEL high level input voltage; PS/SYNC high level input voltage when used for synchronization		1.1			V
	EN, PS/SYNC, VSEL input current				0.2	μA
VOL	PG output low voltage	IPG = -1 mA			0.4	V
ILKG	PG output leakage current	PG pin high impedance; VPG = 5 V			0.2	μA
IPG	PG sink current				1	mA
VTH_PG	Power Good Threshold Voltage, rising Vout		94.5	96	98.5	%
VTH_PG	Power Good Threshold Voltage, falling Vout		90	92	94.5	%
OUTPUT						
VOUT	TPS63070 output voltage range ⁽¹⁾		2.5		9	V
VOUT	TPS630701 output voltage			5.0		V
VFB	TPS63070 feedback voltage	PS/SYNC = VIN		800		mV
	feedback impedance	for fixed voltage versions		1.5		MΩ

(1) Please observe the minimum duty cycle in buck mode

Electrical Characteristics (continued)

 over $V_{IN} = 2V$ to $16V$; $T_j = -40^{\circ}C$ to $125^{\circ}C$; typical values are at $T_j = 25^{\circ}C$ (unless otherwise noted)

PARAMETER		TEST CONDITIONS	MIN	TYP	MAX	UNIT
	feedback leakage	for adjustable version; $V_{FB} = 0.8V$			100	nA
V_{OUT}	TPS63070 output voltage accuracy	PS/SYNC = GND (PWM mode)	-1		1	%
V_{OUT}	TPS63070 output voltage accuracy	PS/SYNC = V_{IN} (PFM mode); $V_{IN} \geq 3V$	-1		3	%
	duty cycle in buck mode		30			%
f_{SW}	Oscillator frequency		2100	2400	2700	kHz
	Frequency range for synchronization		2100		2800	kHz
$I_{IN,max}$	Average, positive input current limit	$V_{IN} = 5.0V$; $V_{OUT} = 6.5V$; $T_j = 0^{\circ}C$ to $125^{\circ}C$	3050	3600	4150	mA
$I_{IN,max}$	Average, negative input current limit	$V_{IN} = 5.0V$; $V_{OUT} = 6.5V$; $T_j = 0^{\circ}C$ to $125^{\circ}C$	1100	1800		mA
$R_{DS(ON)-BUCK}$	High side switch on resistance	$V_{IN} = 5V$		50	80	m Ω
	Low side switch on resistance	$V_{IN} = 5V$		100	160	m Ω
$R_{DS(ON)-BOOST}$	High side switch on resistance	$V_{IN} = 5V$		40	70	m Ω
	Low side switch on resistance	$V_{IN} = 5V$		80	125	m Ω
$R_{DS(ON)-FB2}$	FB2 resistance to GND with VSEL = high			25	100	Ω
I_{LKG}	Input leakage current into FB2 with VSEL=low	$V_{FB} = V_{FB2} = 0.8V$			100	nA
	FB2 sink current				100	μA
	Line regulation	Power Save Mode disabled		0.07		%/V
	Load regulation	Power Save Mode disabled		0.2		%/A
V_{AUX}	Maximum bias voltage	$V_{IN} \geq V_{OUT}$; $V_{IN} < 6V$	$V_{IN} - 0.3$		7	V
		$V_{IN} < V_{OUT}$	$V_{OUT} - 0.3$		7	V
	output discharge resistance	$V_{IN} \geq 2.5V$		250		Ω
t_{delay}	Start-up delay	time from $EN = V_{IH}$ to device starts switching		70		μs
t_{SS}	soft-start time	time to ramp from 5% to 95% of V_{out} ; buck mode; $V_{IN} = 7.2V$, $V_{out} = 3.3V$, $I_{out} = 500mA$		400		μs
		time to ramp from 5% to 95% of V_{out} ; boost mode; $V_{IN} = 3.0V$, $V_{out} = 3.3V$, $I_{out} = 250mA$		850		μs

7.6 Typical Characteristics

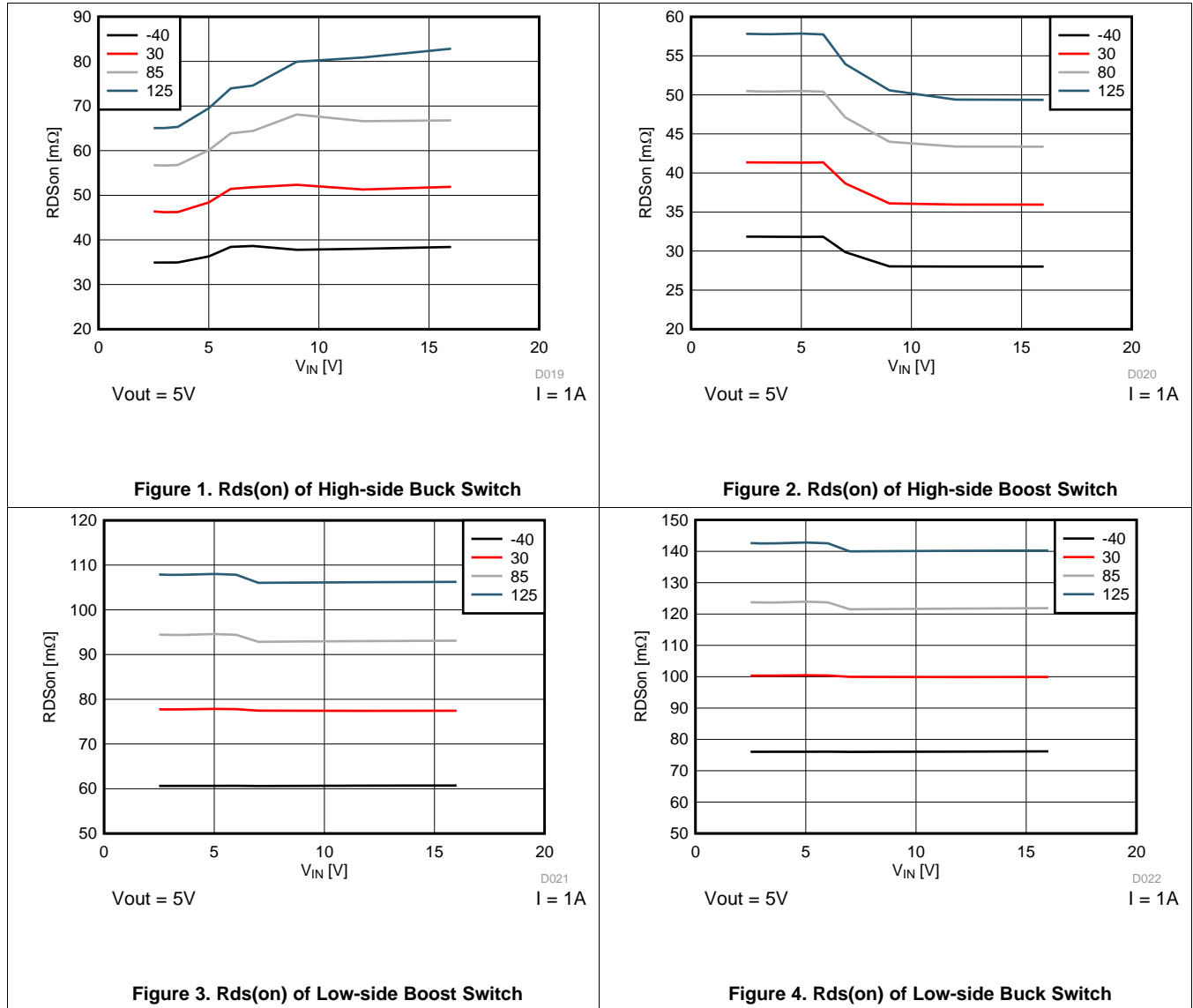

8 Detailed Description

8.1 Overview

The TPS6307x use 4 internal N-channel MOSFETs to maintain synchronous power conversion at all possible operating conditions. This enables the device to keep high efficiency over a wide input voltage and output power range. To regulate the output voltage at all possible input voltage conditions, the device automatically switches from buck operation to boost operation and back as required by the configuration. It always uses one active switch, one rectifying switch, one switch on, and one switch held off. Therefore, it operates as a buck converter when the input voltage is higher than the output voltage, and as a boost converter when the input voltage is lower than the output voltage. There is no mode of operation in which all 4 switches are switching. The RMS current through the switches and the inductor is kept at a minimum, to minimize switching and conduction losses. For the remaining 2 switches, one is kept on and the other is kept off, thus causing no switching losses. Controlling the switches this way allows the converter to always keep high efficiency over the complete input voltage range. The device provides a seamless transition from buck to boost or from boost to buck operation.

8.2 Functional Block Diagram TPS63070

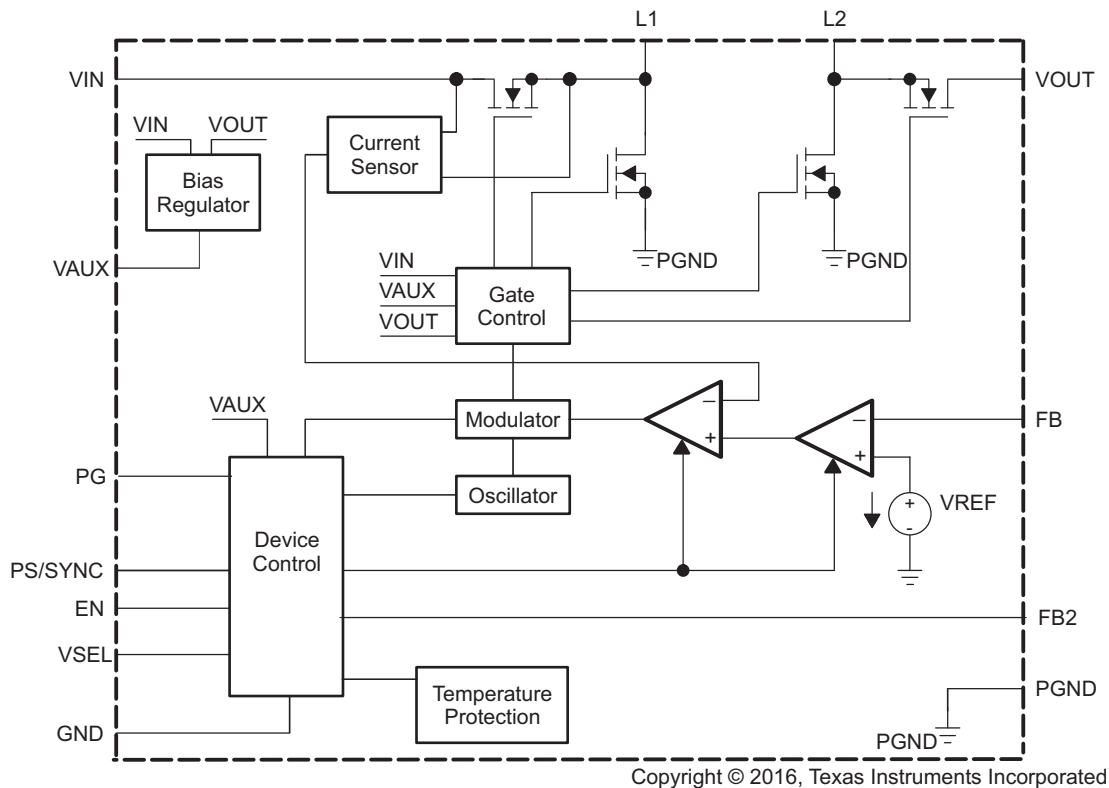

8.3 Functional Block Diagram TPS630701

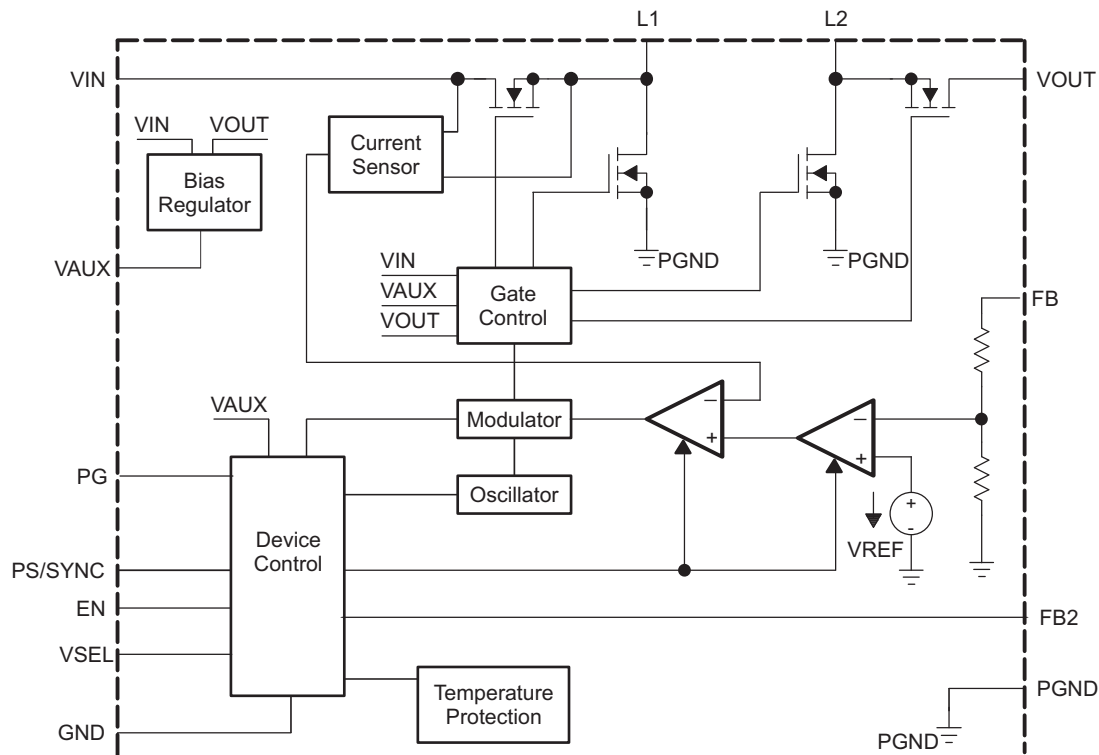

Copyright © 2016, Texas Instruments Incorporated

8.4 Feature Description

8.4.1 Control Loop Description

The controller circuit of the device is based on an average current mode topology. The average inductor current is regulated by a fast current regulator loop which is controlled by a voltage control loop.

The non inverting input of the transconductance amplifier gm_v can be assumed to be constant. The output of gm_v defines the average inductor current. The inductor current is reconstructed by measuring the current through the high side buck MOSFET. This current corresponds exactly to the inductor current in boost mode. In buck mode, the current is measured during the on-time of the same MOSFET. During the off-time, the current is reconstructed internally starting from the peak value reached at the end of the on-time cycle. The average current is then compared to the desired value and the difference, or current error, is amplified and compared to the sawtooth ramp of either the Buck or the Boost. Depending on which of the two ramps is crossed by the signal, either the Buck MOSFETs or the Boost MOSFETs are activated. When the input voltage is close to the output voltage, one buck cycle is followed by a boost cycle. In this condition, not more than three cycle in a row of the same mode are allowed. This control method in the buck-boost region ensures a robust control and the highest efficiency.

For an input voltage above 9 V, and V_{out} below 2.2 V, the switching frequency is reduced by a factor of 2 to keep the minimum on-time at a reasonable value. For short circuit protection, at an output voltage below 1.2V, the low side input FET and the high side output FET are not actively switched but their back-gate diode used for conduction. Therefore an output voltage below 1.5V should in general be avoided.

Feature Description (continued)

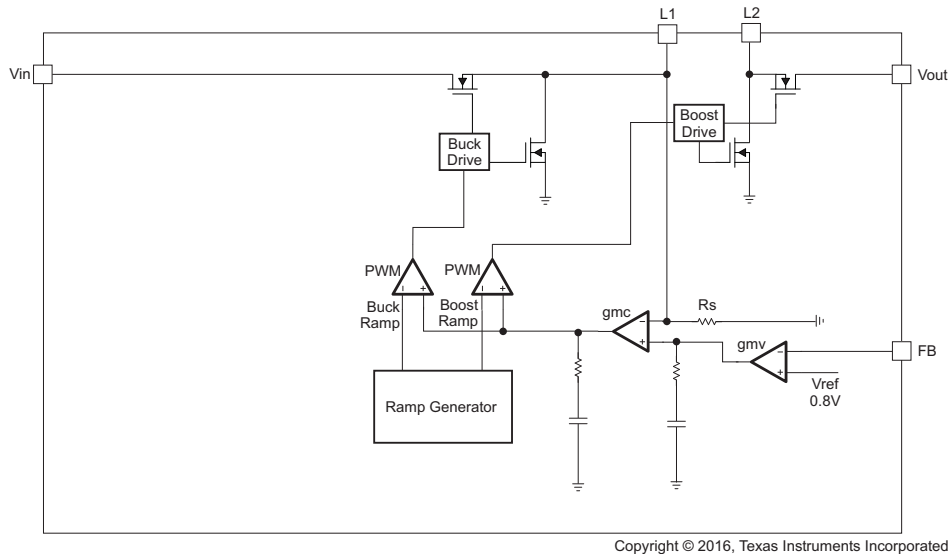

Figure 5. Average Current Mode Control

8.4.2 Enable

The enable pin of the TPS63070 is not just a simple digital input but compares the voltage applied to a fixed threshold of 0.8V for a rising voltage. This allows to drive the pin by a slowly changing voltage and enables the use of an external RC network to achieve a precise power-up delay. The enable input threshold for a falling edge is typically 100mV lower than the rising edge threshold. The TPS63070 starts operation when the rising threshold is exceeded. For proper operation, the EN pin must be terminated and must not be left floating. Pulling the EN pin low forces the device into shutdown. In this mode, the internal high side and low side MOSFETs are turned off and the entire internal-control circuitry is switched off. The enable pin can also be used with an external voltage divider to set a user-defined minimum supply voltage.

It is recommended to not connect EN directly to VIN but use a resistor in series in the range of 1kΩ to 1MΩ. If several inputs like EN and PS/SYNC are connected to VIN, the resistor can be shared. No resistor is required if the pin is driven from an analog or digital signal rather than a supply voltage.

8.4.3 Power Good

The device has a built in power good output that indicates whether the output voltage has reached its nominal value. The PG signal is generated based on the status of the output voltage monitor. The power good circuit operates as long as the converter is enabled and VIN is above the undervoltage lockout threshold.

If the output voltage has not reached the regulated condition, the PG pin is held low. When the regulated condition is reached, PG is high impedance.

The PG output needs an external pull-up resistor. This resistor can be pulled to any voltage up to the maximum output voltage rating.

Table 1. Power Good Status

EN	output voltage status	PG
low	output off	low
high	output voltage above power good threshold	high impedance
high	output voltage below power good threshold, in thermal shutdown or input / output overvoltage protection active	low

8.4.4 Soft Start

To minimize inrush current during start up, the device has a soft start. When the EN pin is set high, after a thermal shutdown or after the undervoltage lockout threshold is exceeded, a soft-start cycle is started and the input current is ramped until the output voltage reaches regulation. The device ramps up the output voltage in a controlled manner, even if a large capacitor is connected at the output. During soft-start, as long as the output voltage is below the power good threshold, the input current limit is reduced to typically 1A.

8.4.5 PS/SYNC

The PS/SYNC pin has two functions:

- switching between forced PWM mode and power save mode
- synchronizing to an external clock applied at pin PS/SYNC

When PS/SYNC is set high, the device operates in power save mode at low output current. For an average inductor current above a certain threshold the device switches to forced PWM mode. The automatic switch-over from PFM to PWM and vice versa is done such that the efficiency is kept at the maximum possible level. It is not based on a fixed threshold but at a current that depends on input voltage and output voltage to keep the efficiency at the maximum possible level.

The power save mode is disabled when PS/SYNC is set low. The device then operates in forced fixed frequency PWM mode independent of the output current.

TPS6307x can be synchronized to an external clock applied at pin PS/SYNC. Details about the voltage level and frequency range can be found in the electrical characteristics. When an external clock is detected, TPS6307x switches from internal clock or power save mode to fixed frequency operation based on the external clock frequency. When the external clock is removed, TPS6307x switches back to internal clock or power save mode depending on the average inductor current and status of the PS/SYNC pin. The PS/SYNC pin has two parallel input stages, a slow one with the precise threshold for PWM/PFM mode change and a fast digital input stage for an external clock signal for synchronization.

It is recommended to not connect PS/SYNC directly to VIN but use a resistor in series in the range of 1k Ω to 1M Ω . If several inputs like EN and PS/SYNC are connected to VIN, the resistor can be shared. No resistor is required if the pin is driven from an analog or digital signal rather than a supply voltage.

8.4.6 Short Circuit Protection

The TPS6307x provides short circuit protection to protect itself and the application. When the output voltage is below 1.2 V, the back-gate diodes of the low side input FET and high side output FET are used for rectification. For an input voltage above 9 V and an output voltage below 2.2 V, the switching frequency is scaled to $\frac{1}{2}$ of its nominal value.

8.4.7 VSEL and FB2 pins

The VSEL pin allows to select between two different output voltages on the adjustable version. The voltage is set by a resistor that is connected between the FB and the FB2 pin. FB2 is connected to GND if VSEL = high. FB2 is high impedance if VSEL= low.

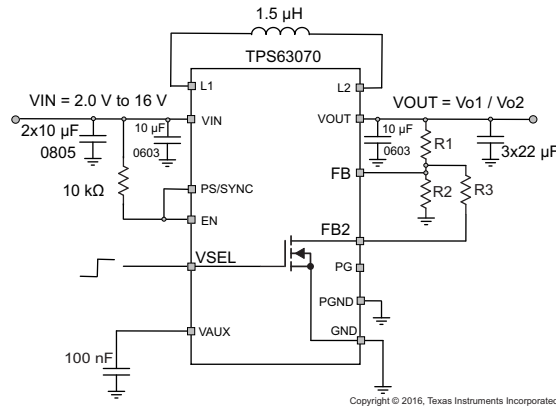

Figure 6. Typical Application using VSEL

The resistor values for the feedback divider and FB2 are in the 50-500kΩ range. R3 is calculated as follows:

$$R3 = \frac{Vo1 \times R1 \times R2^2}{(Vo2 - Vo1)(R1 \times R2 + R2^2)} \text{ for } Vo2 > Vo1 \quad (1)$$

8.4.8 Overvoltage Protection

TPS6307x has a built in over-voltage protection which limits the output voltage. The voltage is internally sensed on the VOUT pin. In case the voltage on the feedback pin is not set correctly or the connection is open, this limits the output voltage to a value that protects the output stage from a too high voltage by limiting it to an internally set value.

Input over-voltage protection forces PFM mode to make sure the device is protected against boosting from the output to the input. This may happen if there is a large capacitor charged above the nominal voltage on the output and the supply on the input is removed. In PWM mode, the device is able to provide current from the output to the input causing a rise in the input voltage. In PFM mode, the current to the input is blocked so the input voltage can not rise. The input over-voltage protection does not protect the device from a too high voltage applied to the input but just from operating such that the device itself causes a rise of the input voltage above critical levels. Both over-voltage sensors are de-glitched by approximately 1µs.

8.4.9 Undervoltage Lockout

When the input voltage drops, the undervoltage lockout prevents mis-operation by switching off the device. The converter starts operation when the input voltage exceeds the threshold by a hysteresis of typically 850 mV. This relatively large hysteresis is needed to allow operation down to 2-V of supply voltage for the case when the output voltage is up at 3-V or above but restrict start-up for the case when the output voltage is zero. For start-up when the output voltage has not yet ramped, the rising UVLO threshold was set to a level that allows to start TPS63070 at a supply voltage where the load does not demand much load current.

8.4.10 Overtemperature Protection

The junction temperature (Tj) of the device is monitored by an internal temperature sensor. When Tj exceeds the thermal shutdown temperature, the device goes into thermal shutdown. The power stage is turned off and PG goes low. When Tj decreases below the hysteresis amount, the converter resumes normal operation, beginning with a Soft Start cycle. To avoid unstable conditions, a hysteresis of typically 20°C is implemented on the thermal shutdown temperature. In addition, the thermal shutdown is debounced by approximately 10 µs.

8.5 Device Functional Modes

8.5.1 Power Save Mode

Depending on the load current, in order to provide the best efficiency over the complete load range, the device works in PWM mode at an inductor current of approximately 650 mA or higher. At lighter load, the device switches automatically in to Power Save Mode to reduce power consumption and extend battery life. The PFM/PWM pin can be used to select between the two different operation modes. To enable Power Save Mode, the PFM/PWM pin must be set high.

During Power Save Mode, the part operates with a reduced switching frequency and supply current to maintain high efficiency. The output voltage is monitored by a comparator for the threshold "comp low" and "comp high" at every clock cycle. When the device enters Power Save Mode, the converter stops operating and the output voltage drops. The slope of the output voltage depends on the load and the output capacitance. When the output voltage reaches the comp low threshold, at the next clock cycle the device ramps up the output voltage again by starting operation. Operation can last for one or several pulses until the "comp high" threshold is reached. At the next PFM cycle, if the output current is still lower than about 650 mA, the device switches off again and the same operation is repeated. Instead, if at the next PFM cycle, the load is above approximately 650 mA, the device automatically switches to PWM mode.

In order to keep high efficiency in PFM mode, there is only a comparator active to keep the output voltage regulated. The AC ripple in this condition is increased, compared to the voltage in PWM mode. The amplitude of this voltage ripple typically is 50 mV pk-pk, with 22 μ F effective capacitance. In order to avoid a critical voltage drop when switching from 0 A to full load, the output voltage in PFM is typically 1 % above the nominal value in PWM. This allows the converter to operate with a small output capacitor and still have a low absolute voltage drop during heavy load transients.

Power Save Mode can be disabled by programming the PFM/PWM pin low.

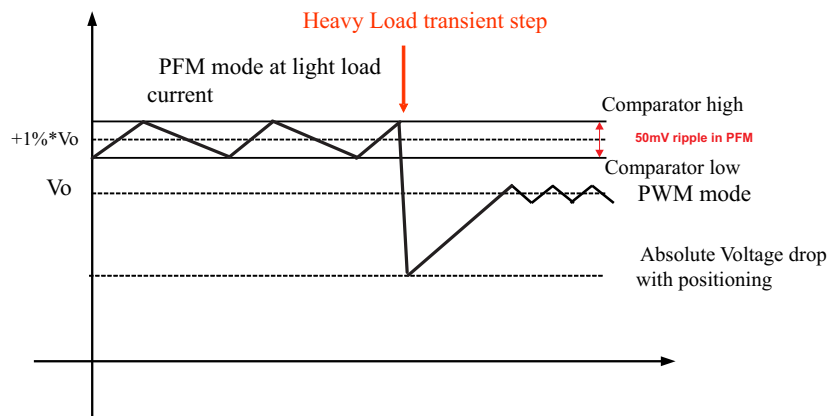

Figure 7. Dynamic Voltage Positioning

8.5.2 Current Limit

It is possible to calculate the output current in the different conditions in boost mode using [Equation 2](#) and [Equation 3](#) and in buck mode using [Equation 4](#) and [Equation 5](#).

$$\text{Duty Cycle Boost} \quad D = \frac{V_{\text{OUT}} - V_{\text{IN}}}{V_{\text{OUT}}} \quad (2)$$

$$\text{Output Current Boost} \quad I_{\text{OUT}} = \eta \times I_{\text{IN}} (1-D) \quad (3)$$

$$\text{Duty Cycle Buck} \quad D = \frac{V_{\text{OUT}}}{V_{\text{IN}}} \quad (4)$$

Device Functional Modes (continued)

$$\text{Output Current Buck } I_{\text{OUT}} = (\eta \times I_{\text{IN}}) / D \quad (5)$$

With,

η = Estimated converter efficiency (use the number from the efficiency curves or 0.90 as an assumption)

f = Converter switching frequency (typical 2.4MHz)

L = Selected inductor value

I_{IN} =Minimum average input current (, , and)

8.5.3 Output Discharge Function (optional)

To make sure the load applied at TPS63070 is powered up from 0 V once TPS63070 is enabled, the device features an internal discharge resistor for the output capacitor. The discharge function is enabled as soon as the device is disabled, in thermal shutdown or in undervoltage lockout. The minimum supply voltage required for the discharge function to remain active when enabled is approximately 2 V. The discharge function is only active after the device has been enabled at least once after supply voltage was applied.

9 Application and Implementation

NOTE

Information in the following applications sections is not part of the TI component specification, and TI does not warrant its accuracy or completeness. TI's customers are responsible for determining suitability of components for their purposes. Customers should validate and test their design implementation to confirm system functionality.

9.1 Application Information

The TPS6307x is a high efficiency, low quiescent current buck-boost converter suitable for applications where the input voltage can be higher or lower than the output voltage. The TPS63070 is internally supplied from the higher of the input voltage or output voltage. For proper operation either one or both need to have a voltage of 3.0 V or above but must not exceed their maximum rating.

9.2 Typical Application for adjustable version

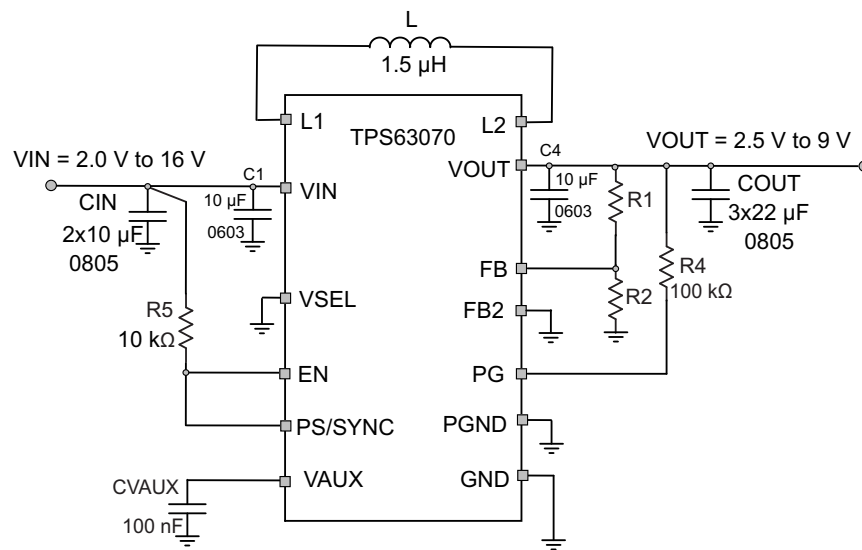

Copyright © 2016, Texas Instruments Incorporated

Figure 8. Typical Application For Adjustable Version

9.2.1 Design Requirements

The design guidelines provide a component selection to operate the device within the recommended operating conditions. The input and output capacitors have been split into a small 0603 size capacitor close to the device pins and 0805 size capacitors to get the required capacitance.

Table 2. Bill of Materials

REFERENCE	DESCRIPTION	VALUE	MANUFACTURER
IC	TPS63070RNM		Texas Instruments
L	XFL4020-152ME	1.5 µH	Coilcraft
CIN	GRM21BC71E106ME11L	2 x 10 µF / 25 V / X7S / 0805	Murata
C1	TMK107BBJ106MA-T	10 µF / 25 V / X5R / 0603	Taiyo Yuden
COUT	GRM21BC81C226ME44L	3 x 22 µF / 16 V / X6S / 0805	Murata
C4	TMK107BBJ106MA-T	10 µF / 25 V / X5R / 0603	Taiyo Yuden

Table 2. Bill of Materials (continued)

REFERENCE	DESCRIPTION	VALUE	MANUFACTURER
CVAUX	TMK105B7104MV-FR	100 nF / 25V / X7R / 0402	Taiyo Yuden
R1, R2	Metal Film Resistor ; 1%	depending on desired output voltage	
R4	Metal Film Resistor ; 1%	100 kΩ	

9.2.2 Detailed Design Procedure

The TPS6307x series of buck-boost converter has internal loop compensation. Therefore, the external L-C filter has to be selected according to the internal compensation. It's important to consider that the effective inductance, due to inductor tolerance and current derating can vary between 20% and -30%. The same for the capacitance of the output filter: the effective capacitance can vary between +20% and -80% of the specified datasheet value, due to capacitor tolerance and bias voltage. For this reason, [Output Filter Selection](#) shows the nominal capacitance and inductance value allowed. The effective capacitance of the adjustable version TPS63070 on the output (in μF) needs to be at least 10 times higher than the effective inductance (in μH) to ensure a good transient response and stable operation.

Table 3. Output Filter Selection

INDUCTOR VALUE [μH] ⁽¹⁾	OUTPUT CAPACITOR VALUE [μF] ⁽²⁾			
	22	47	68	100
1.0		√	√	√
1.5		√ ⁽³⁾	√	√
2.2			√	√

- (1) Inductor tolerance and current de-rating is anticipated. The effective inductance can vary by +20% and -30%.
- (2) Capacitance tolerance and bias voltage de-rating of +20% and -50% is anticipated. For capacitors with larger dc bias effect, a larger nominal value needs to be selected.
- (3) Typical application. Other check marks indicates recommended filter combinations

9.2.2.1 Programming The Output Voltage

While the output voltage of the TPS63070 is adjustable, the TPS630701 is set to a fixed voltage. For fixed output versions, the FB pin must be connected to the output directly. The adjustable version can be programmed for output voltages from 0.8V to 9V by using a resistive divider from VOUT to GND. The voltage at the FB pin (V_{REF}) is regulated to 800mV. The value of the output voltage is set by the selection of the resistive divider from [Equation 6](#). It is recommended to choose resistor values which allow a current of at least 2μA, meaning the value of R2 shouldn't exceed 400kΩ. Lower resistor values are recommended for highest accuracy and most robust design.

$$R_1 = R_2 \left(\frac{V_{OUT}}{V_{REF}} - 1 \right) \quad (6)$$

Table 4. Typical Resistor Values

Output Voltage	R1	R2
3.3 V	470 kΩ	150 kΩ
5.0 V	680 kΩ	130 kΩ
5.3 V	560 kΩ	100 kΩ
5.5 V	300 kΩ	51 kΩ
6.5 V	360 kΩ	51 kΩ
9 V	402 kΩ	39 kΩ

9.2.2.2 Inductor Selection

For high efficiencies, the inductor should have a low dc resistance to minimize conduction losses. Especially at high switching frequencies, the core material has a higher impact on efficiency. When using small chip inductors, the efficiency is reduced mainly due to higher inductor core losses. This needs to be considered when selecting the appropriate inductor. The inductor value determines the inductor ripple current. The larger the inductor value, the smaller the inductor ripple current and the lower the conduction losses of the converter. Conversely, larger inductor values cause a slower load transient response. To avoid saturation of the inductor, the peak current for the inductor in steady state operation is calculated using Equation 8. Only the equation which defines the switch current in boost mode is shown, because this provides the highest value of current and represents the critical current value for selecting the right inductor.

$$\text{Duty Cycle Boost} \quad D = \frac{V_{OUT} - V_{IN}}{V_{OUT}} \quad (7)$$

$$I_{PEAK} = \frac{I_{out}}{\eta \times (1 - D)} + \frac{V_{in} \times D}{2 \times f \times L} \quad (8)$$

Where,

D =Duty Cycle in Boost mode

f = Converter switching frequency (typical 2.4MHz)

L = Selected inductor value

η = Estimated converter efficiency (use the number from the efficiency curves or 0.90 as an assumption)

Note: The calculation must be done for the minimum input voltage which is possible to have in boost mode

Calculating the maximum inductor current using the actual operating conditions gives the minimum saturation current of the inductor needed. It is recommended to choose an inductor with a saturation current 20% higher than the value calculated from Equation 8. The following inductors are recommended for use:

Table 5. Inductor Selection

INDUCTOR VALUE	COMPONENT SUPPLIER ⁽¹⁾	SIZE (LxWxH /mm)	Isat/DCR
1.2 μH	Coilcraft, XFL4015-122ME	4 x 4 x 1.5	4.5 A / 18.8 mΩ
1.5 μH	Coilcraft, XFL4020-152ME	4 x 4 x 2.1	4.6 A / 14.4 mΩ
1.0 μH	Coilcraft, XFL4020-102ME	4 x 4 x 2.1	5.4 A / 10.8 mΩ
1 μH	Murata, 1277AS-H-1R0M	3.2 x 2.5 x 1.2	3.7 A / 45 mΩ

(1) See [Third-party Products Disclaimer](#)

The inductor value also affects the stability of the feedback loop. In particular the boost transfer function exhibits a right half-plane zero. The frequency of the right half plane zero is inverse proportional to the inductor value and the load current. This means the higher the value of the inductance and load current, the more the right half plane zero is moved to a lower frequency. This degrades the phase margin of the feedback loop. It is recommended to choose the inductor's value in order to have the frequency of the right half plane zero >400 kHz. The frequency of the RHPZ is calculated using Equation 9.

$$f_{RHPZ} = \frac{(1 - D)^2 \times V_{out}}{2\pi \times I_{out} \times L} \quad (9)$$

With,

D =Duty Cycle in Boost mode

Note: The calculation must be done for the minimum input voltage which is possible to have in boost mode

If the operating conditions results in a frequency of the RHPZ of less than 400kHz, more output capacitance should be added to reduce the cross over frequency.

9.2.2.3 Capacitor Selection

9.2.2.3.1 Input Capacitor

It is recommended to use a combination of capacitors on the input. A small size ceramic capacitor as close as possible from the VIN pin to GND to block high frequency noise and a larger one in parallel for the required capacitance on for good transient behavior of the regulator. X5R or X7R ceramic capacitor are recommended. The input capacitor needs to be large enough to avoid supply voltage dips shorter than 5us as the undervoltage lockout circuitry needs time to react.

9.2.2.3.2 Output Capacitor

Same as the input, the output capacitor should be a combination of capacitors optimized for suppressing high frequency noise and a larger capacitor for low output voltage ripple and stable operation. The use of small X5R or X7R ceramic capacitors placed as close as possible to the VOUT and GND pins of the IC is recommended. A 0603 size capacitor close to the pins of the IC and as many 0805 capacitors as required to get the capacitance given the output voltage and dc bias effect of the ceramic capacitors is best. The recommended typical output capacitor values are outlined in [Output Filter Selection](#). Please also see the [Recommended Operating Conditions](#) for the minimum and maximum capacitance at the output.

Larger capacitors will cause lower output voltage ripple as well as lower output voltage drop during load transients.

Table 6. Typical Capacitors

VALUE	PART NUMBER	COMPONENT SUPPLIER ⁽¹⁾	COMMENT	SIZE (LxWxH mm)
22 μ F	EMK212BBJ226MG-T	Taiyo Yuden	input capacitor for $V_{in} \leq 8$ V	2 x 1.25 x 1.25
22 μ F	TMK316BBJ226ML	Taiyo Yuden	input capacitor	3.2 x 1.6 x 1.6
10 μ F	TMK107BBJ106MA-T	Taiyo Yuden	bypass capacitor directly at device pins on VIN to GND and VOUT to GND	1.6 x 0.8 x 0.8
10 μ F	GRM21BC71E106ME11	Murata	small body size; 2 parts required if used at $V_{in} > 6$ V	2 x 1.25 x 1.25
22 μ F	GRM21BC81C226ME44	Murata	small body size; 3 parts required if used at $V_o > 5$ V; otherwise 2 parts	2 x 1.25 x 1.25

(1) See [Third-party Products Disclaimer](#)

9.2.3 Application Curves

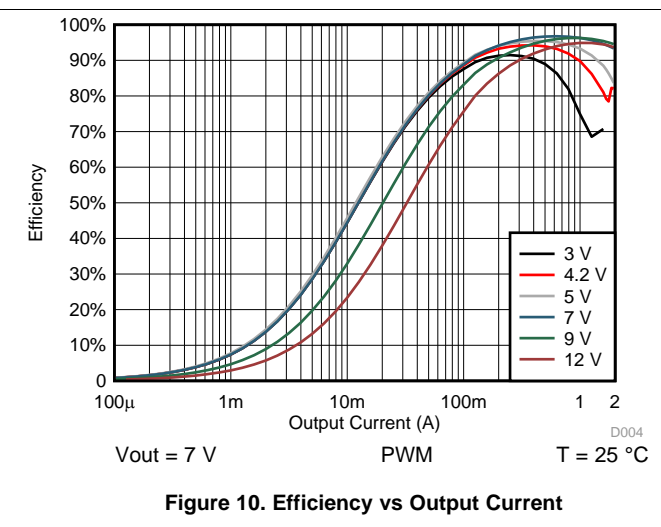
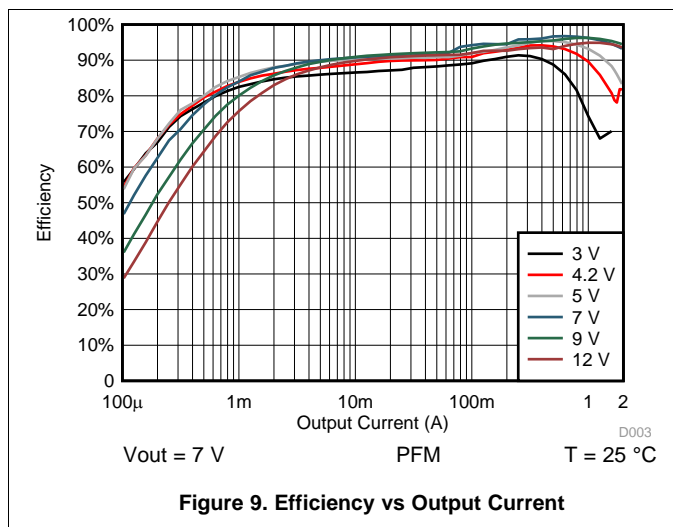

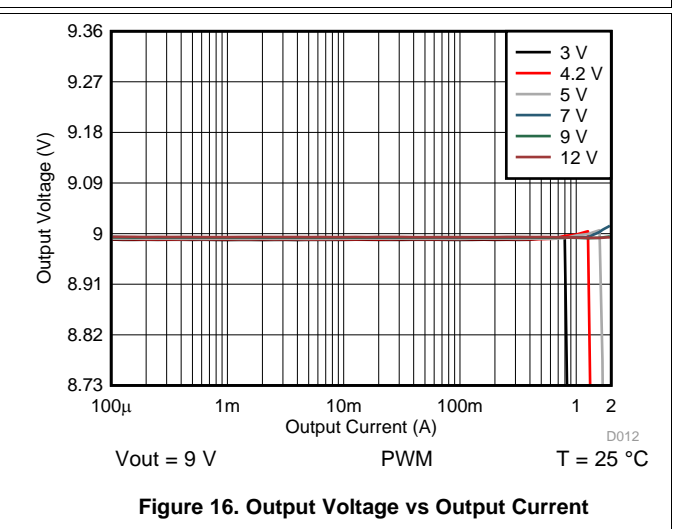
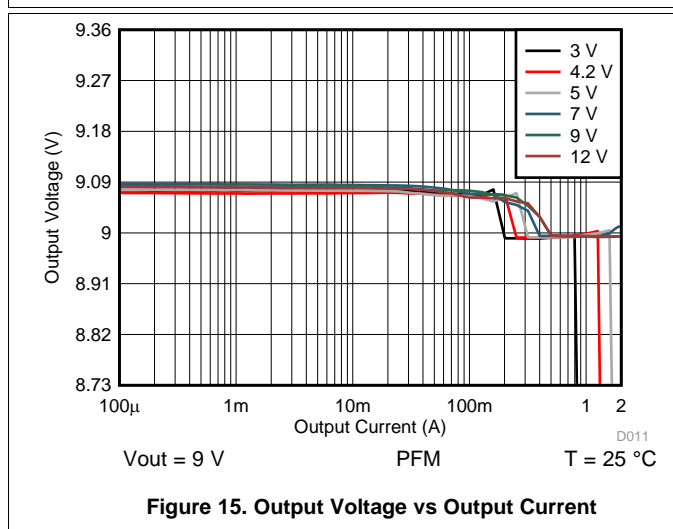
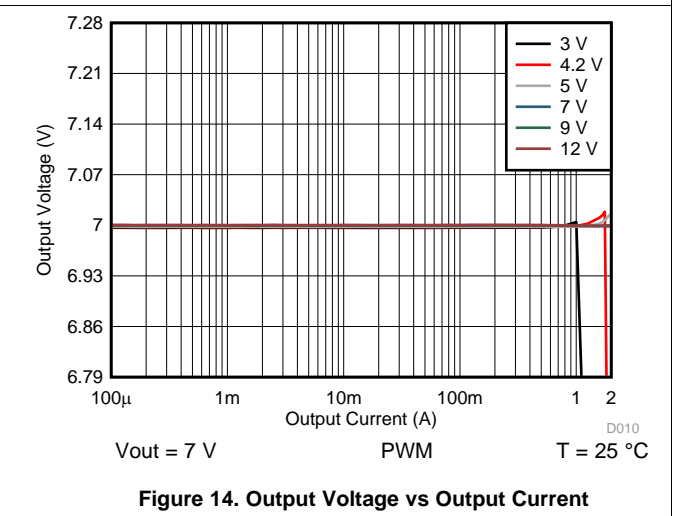
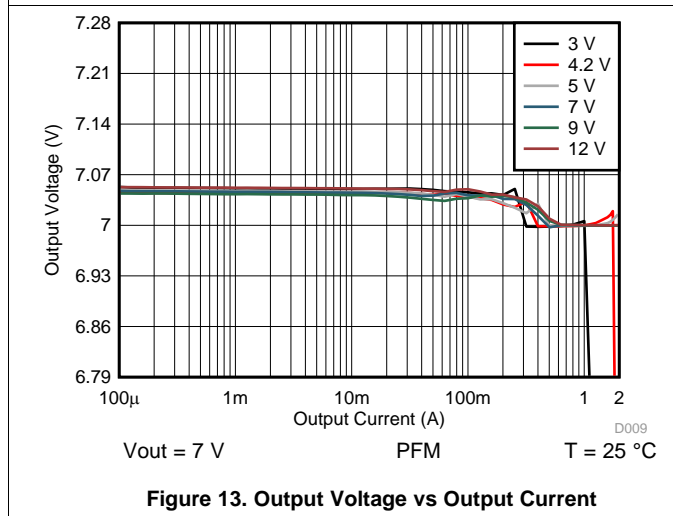
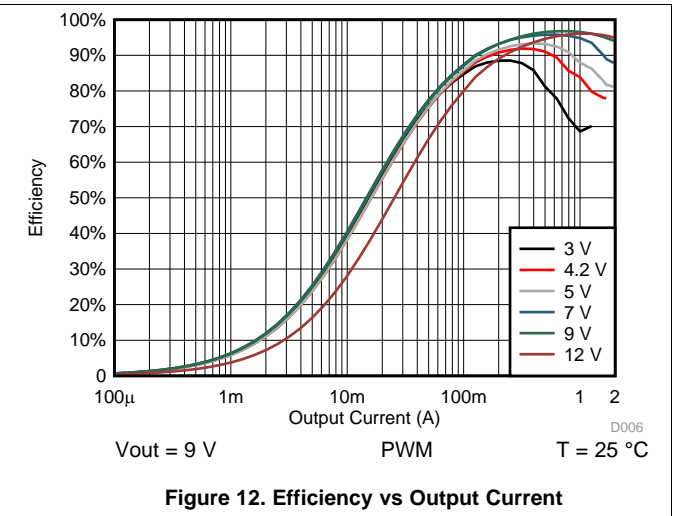
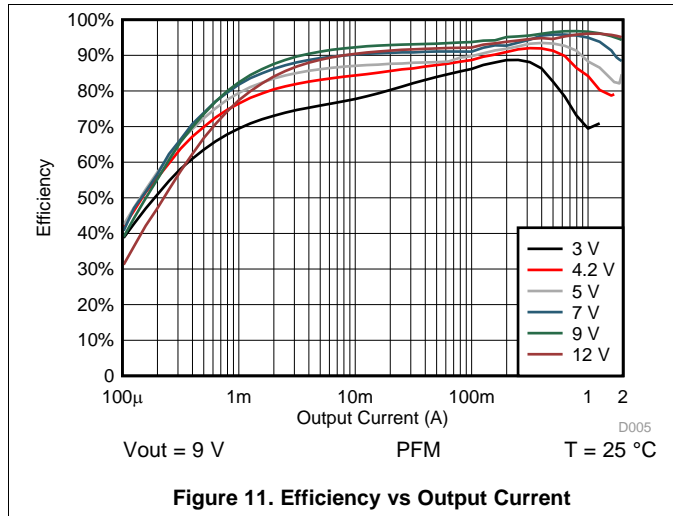

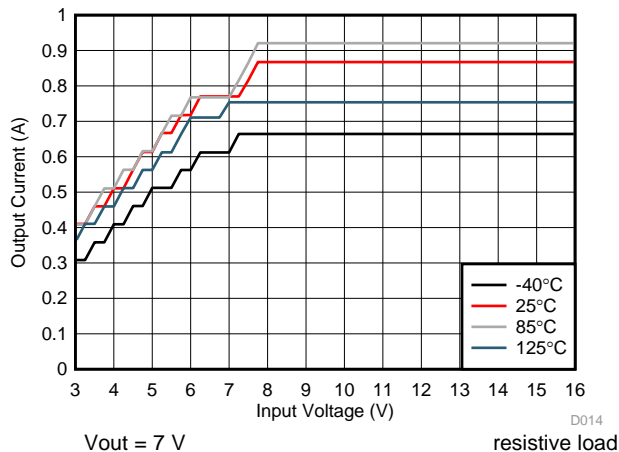

Figure 17. Typical Start-up Current

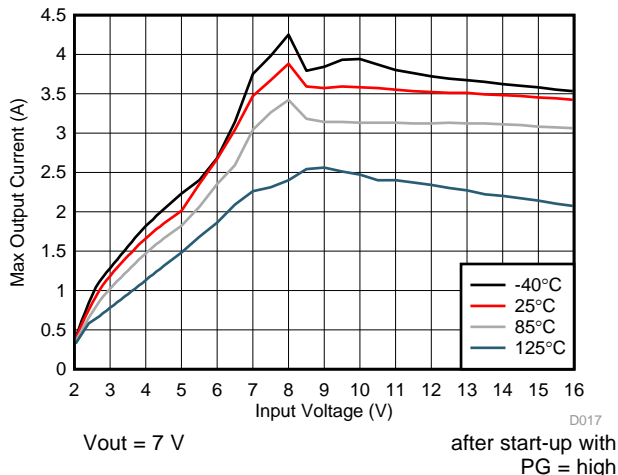

Figure 18. Maximum Load Current vs Input Voltage

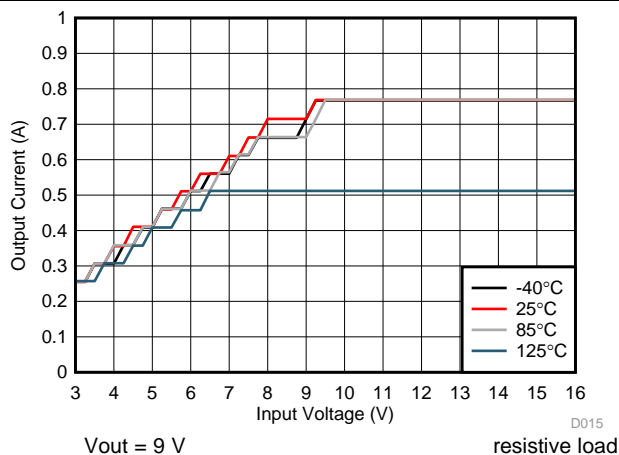

Figure 19. Typical Start-up Current

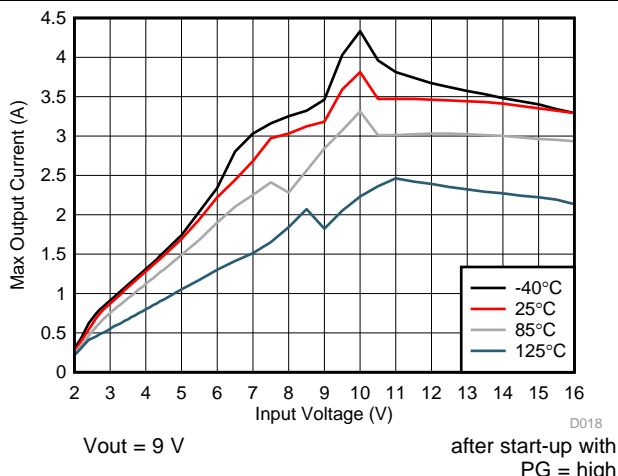

Figure 20. Maximum Load Current vs Input Voltage

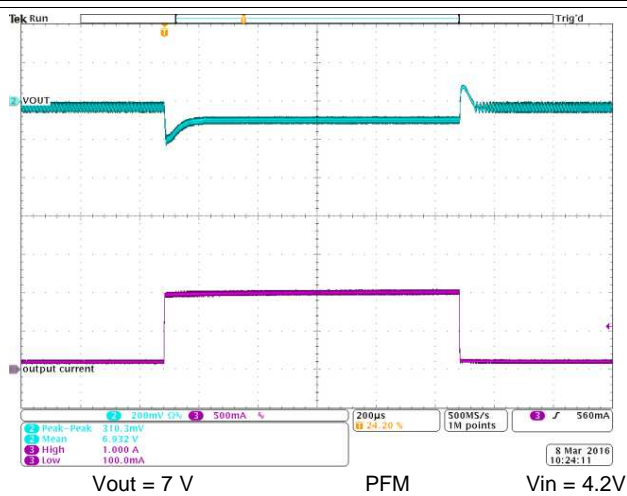

Figure 21. Load Transient Response

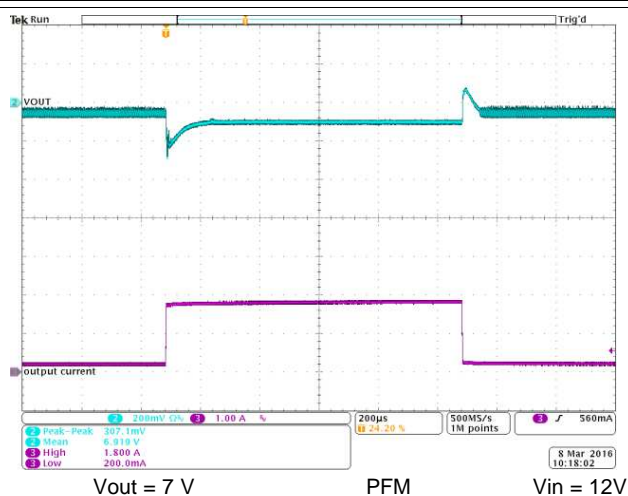

Figure 22. Load Transient Response

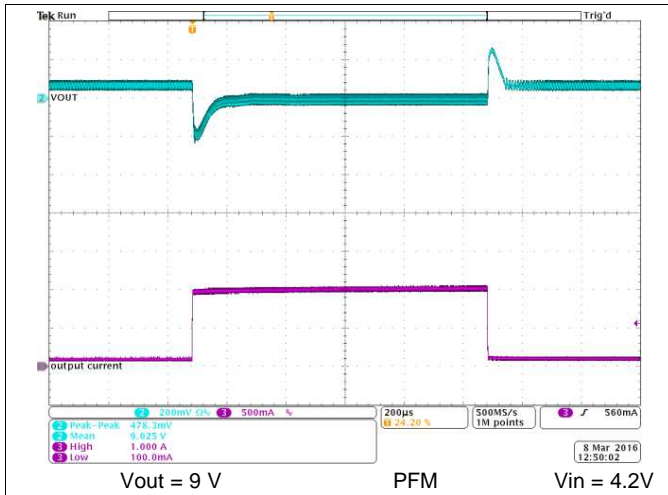

Figure 23. Load Transient Response

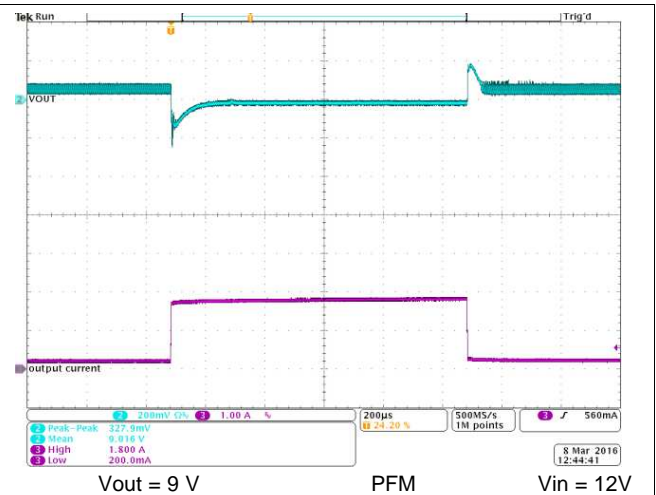

Figure 24. Load Transient Response

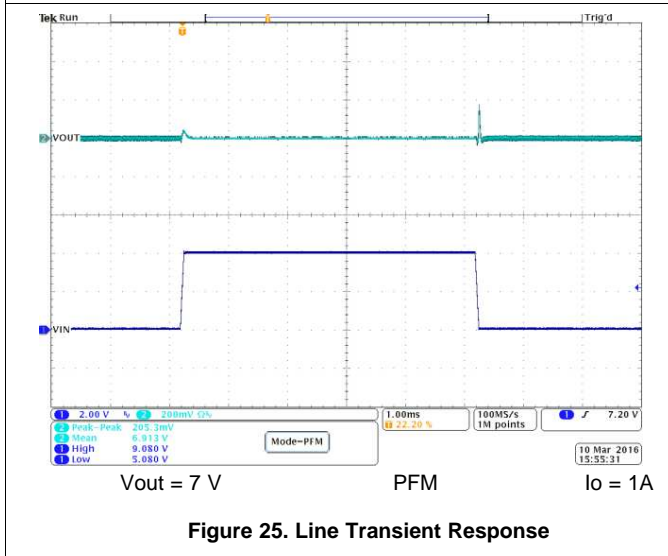

Figure 25. Line Transient Response

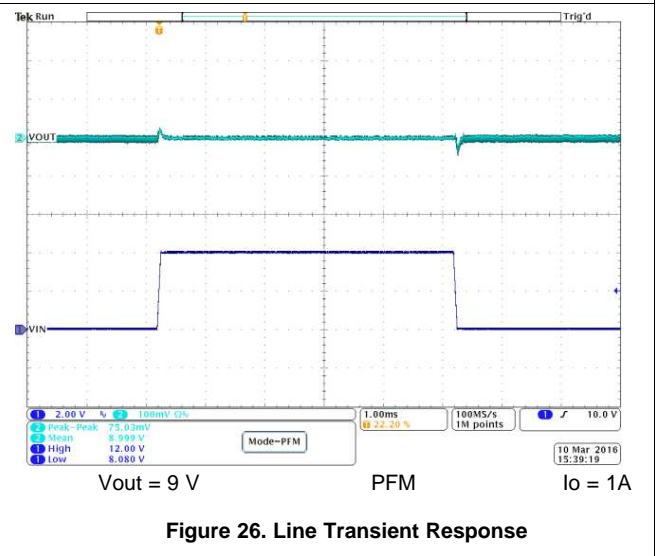

Figure 26. Line Transient Response

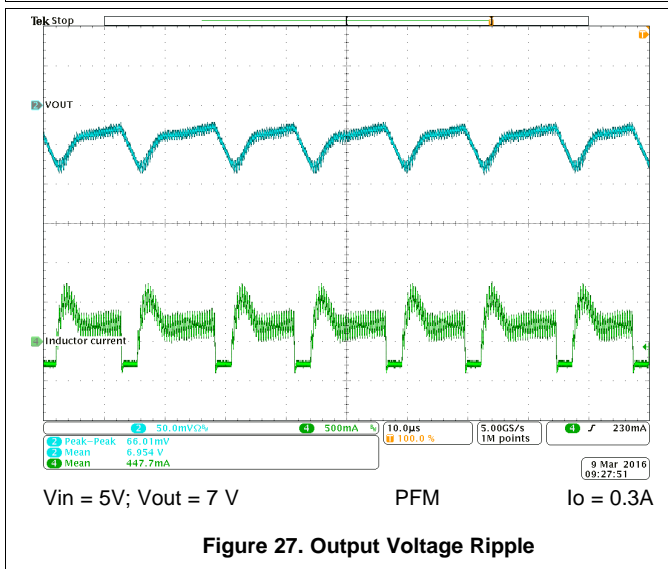

Figure 27. Output Voltage Ripple

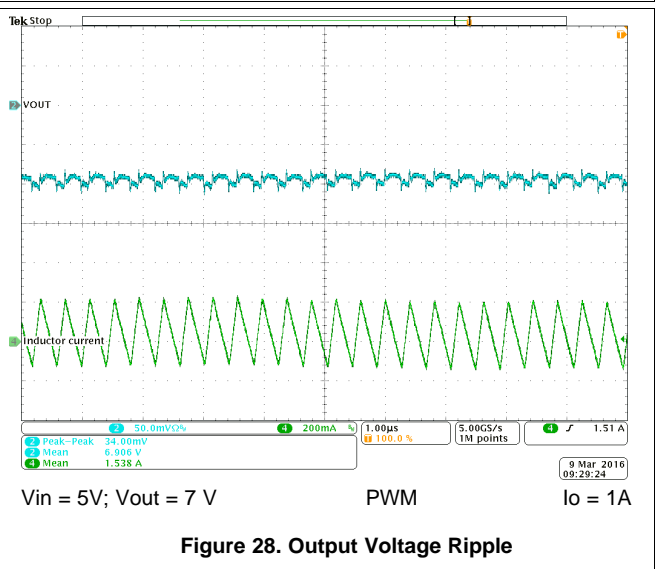

Figure 28. Output Voltage Ripple

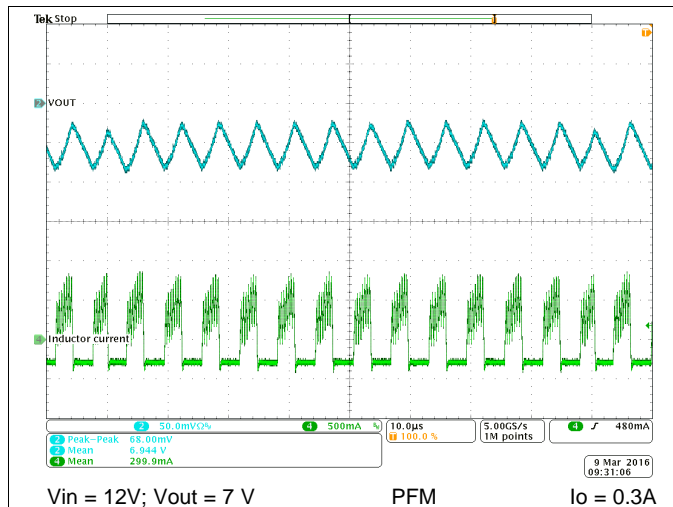

Figure 29. Output Voltage Ripple

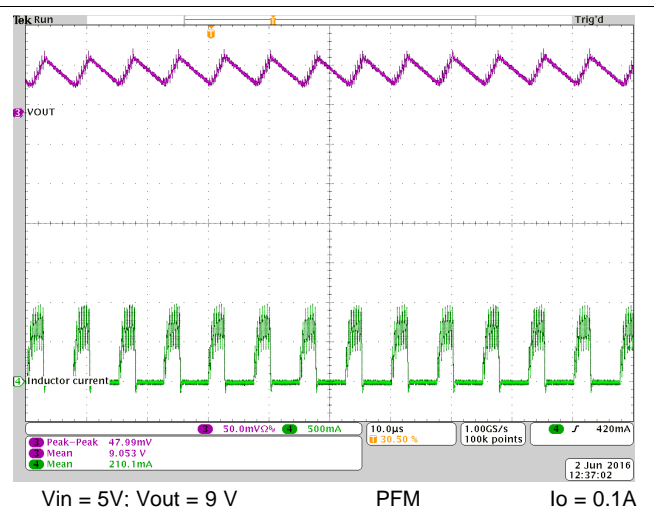

Figure 30. Output Voltage Ripple

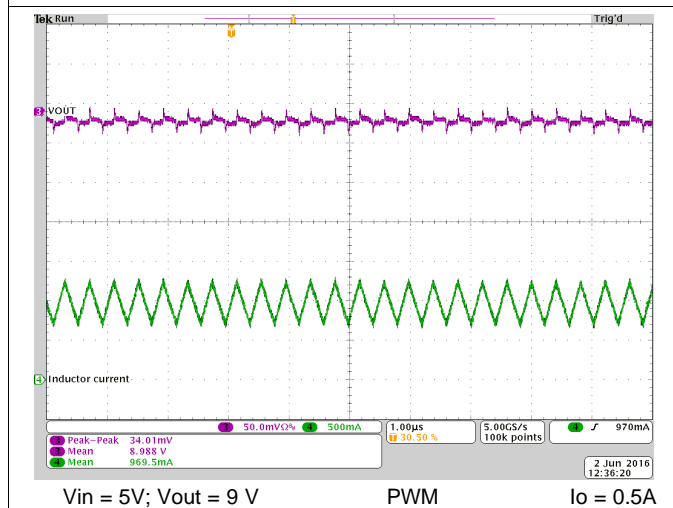

Figure 31. Output Voltage Ripple

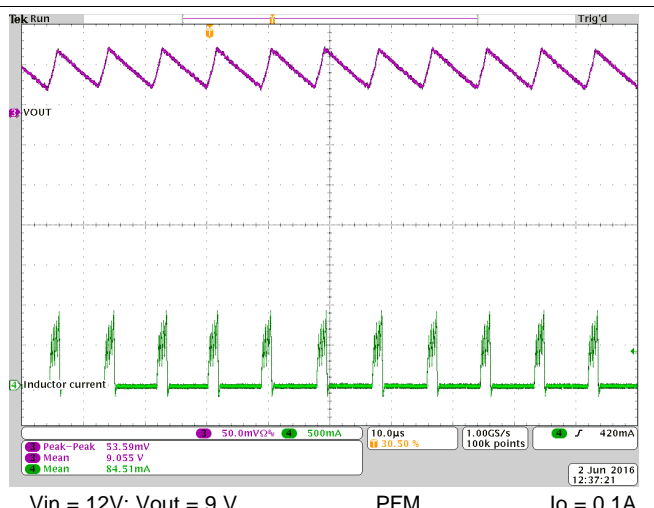

Figure 32. Output Voltage Ripple

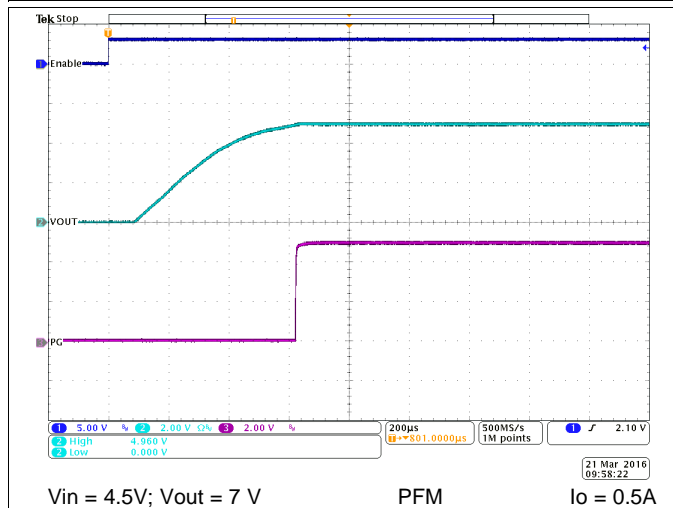

Figure 33. Start-up Timing

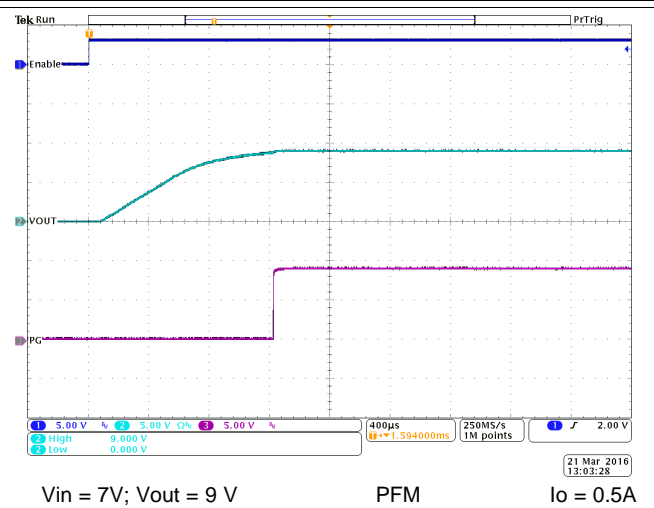
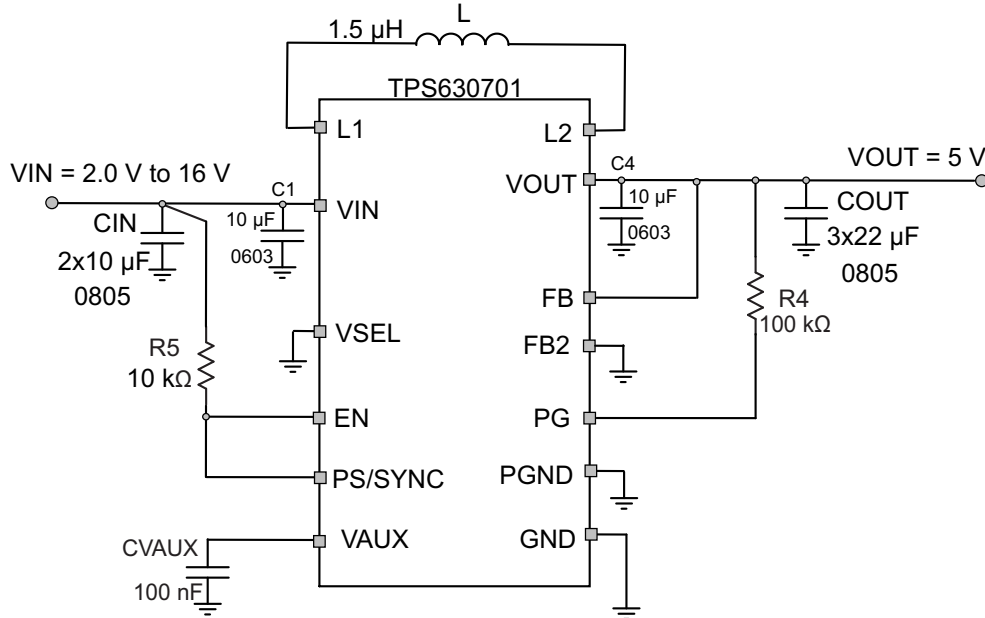

Figure 34. Start-up Timing

9.3 Typical Application for Fixed Voltage Version



Copyright © 2016, Texas Instruments Incorporated

Figure 35. Typical Application For Fixed Voltage Version With Minimum External Part Count And Minimum Soft Start Time

9.3.1 Design Requirements

The design guidelines provide a component selection to operate the device within the recommended operating conditions. The input and output capacitors have been split into a small 0603 size capacitor close to the device pins and 0805 size capacitors to get the required capacitance.

Table 7. Bill of Materials

REFERENCE	DESCRIPTION	VALUE	MANUFACTURER
IC	TPS630701RNM		Texas Instruments
L	XFL4020-1.5µH	1.5 µH	Coilcraft
CIN	GRM21BC71E106ME11L	2 x 10 µF / 25 V / X7S / 0805	Murata
C1	TMK107BBJ106MA-T	10 µF / 25 V / X5R / 0603	Taiyo Yuden
COUT	GRM21BC81C226ME44L	3 x 22 µF / 16 V / X6S / 0805	Murata
C4	TMK107BBJ106MA-T	10 µF / 25 V / X5R / 0603	Taiyo Yuden
CVAUX	TMK105B7104MV-FR	100 nF / 25V / X7R / 0402	Taiyo Yuden
R4	Metal Film Resistor ; 1%	100 kΩ	-

9.3.2 Detailed Design Procedure

The TPS6307x series of buck-boost converter has internal loop compensation. Therefore, the external L-C filter has to be selected according to the internal compensation. It's important to consider that the effective inductance, due to inductor tolerance and current derating can vary between 20% and -30%. The same for the capacitance of the output filter: the effective capacitance can vary between +20% and -80% of the specified datasheet value, due to capacitor tolerance and bias voltage. For this reason, [Output Filter Selection](#) shows the nominal capacitance and inductance value allowed. For the fixed voltage version TPS630701, the effective capacitance on the output (in μF) needs to be at least 15 times higher than the effective inductance (in μH) to ensure a good transient response and stable operation.

9.3.3 Application Curves

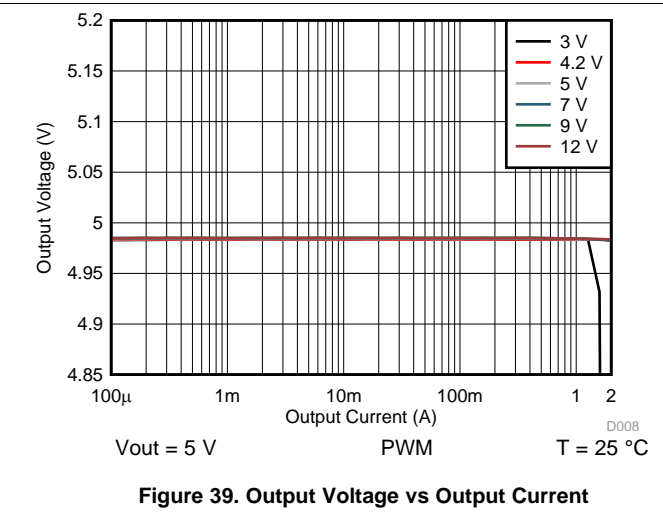
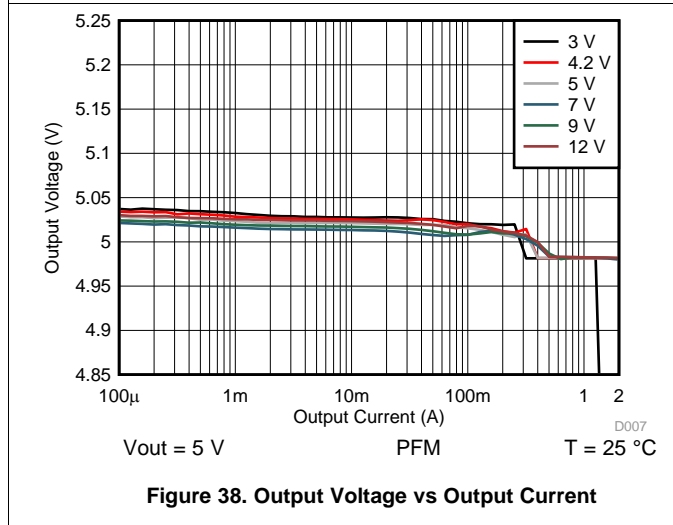
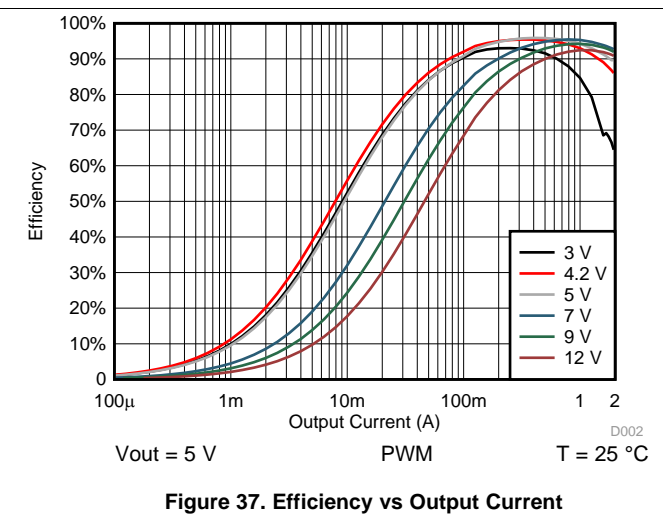
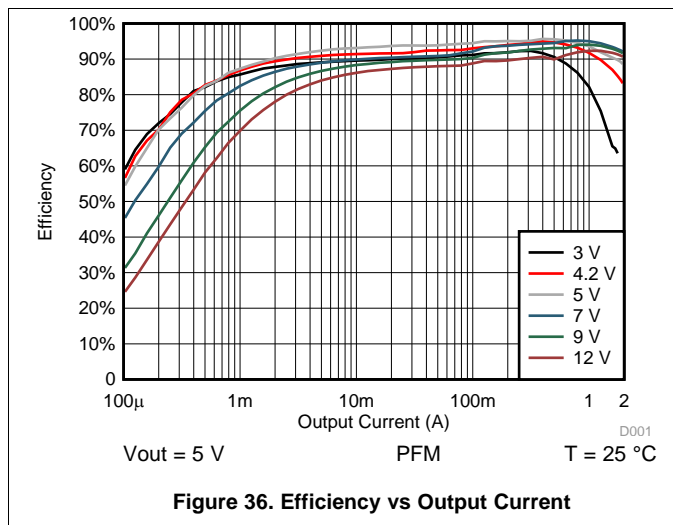

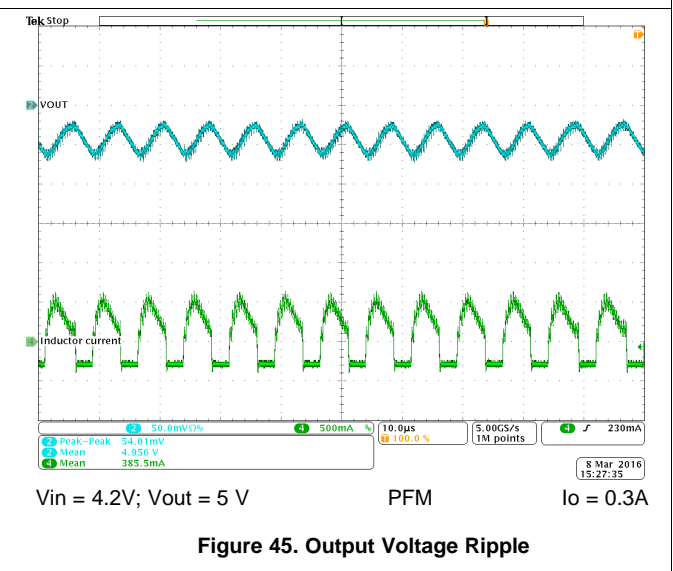
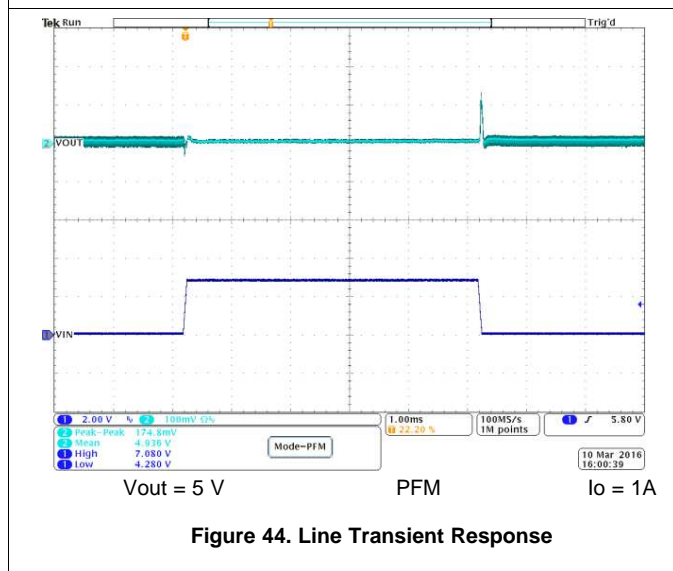
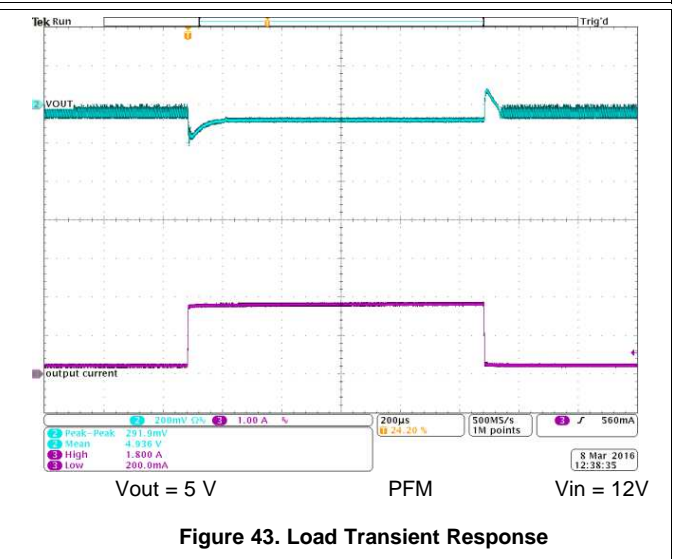
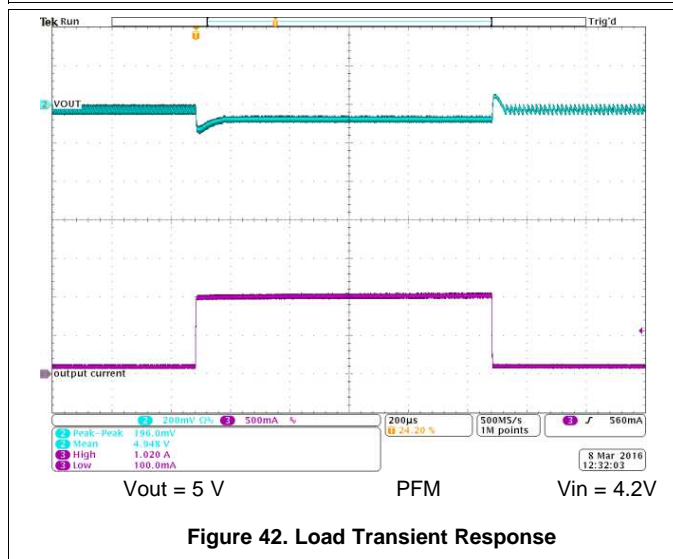
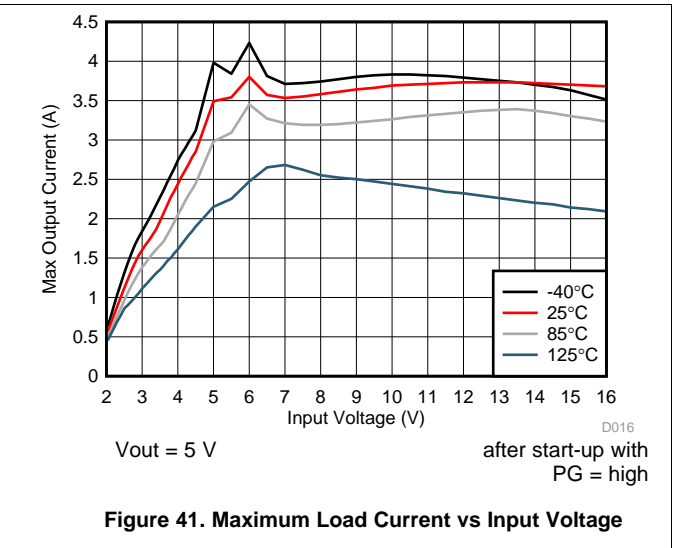
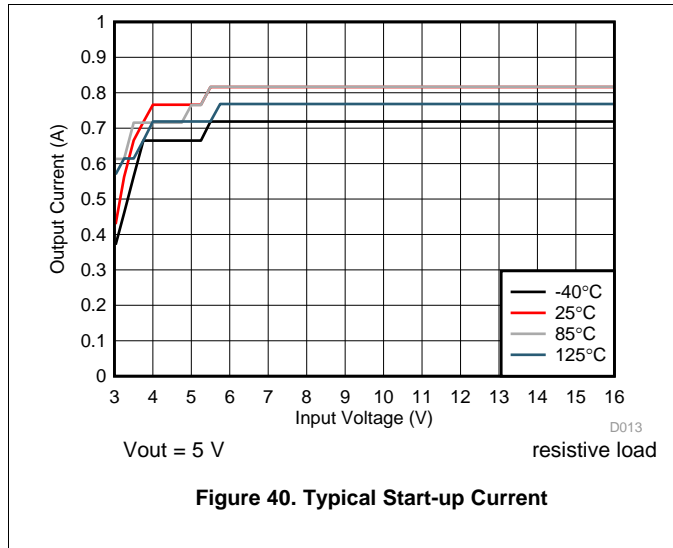

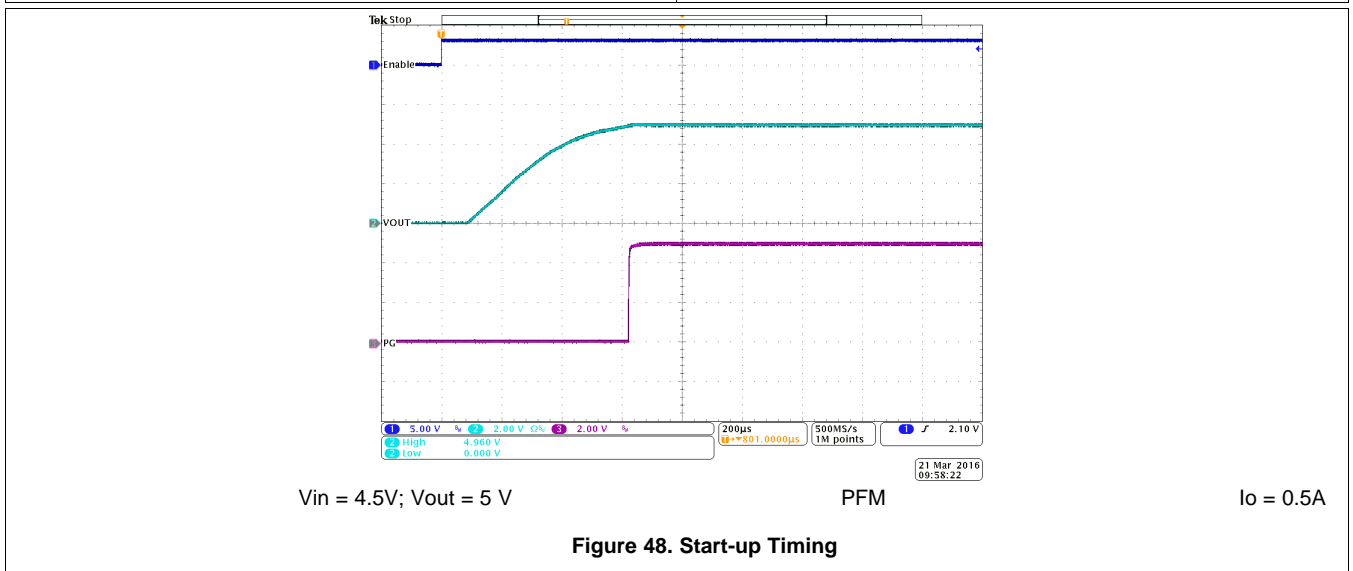
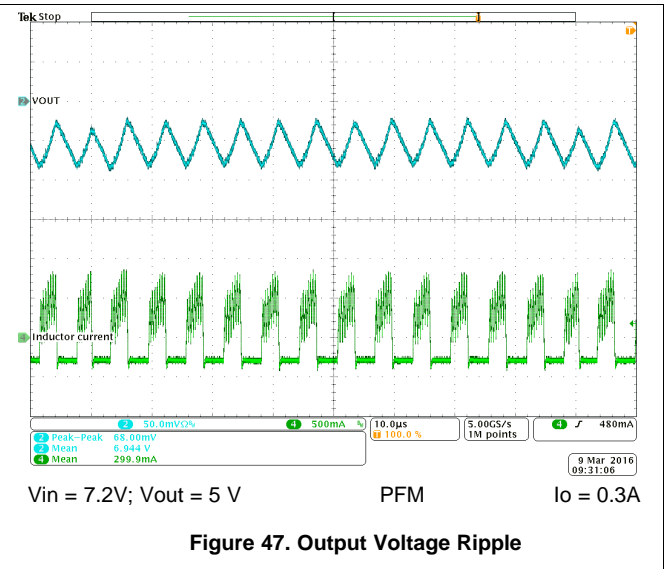
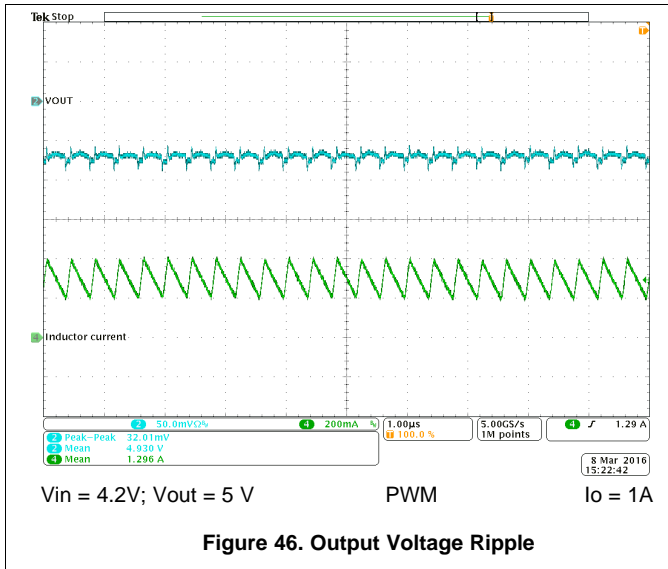

10 Power Supply Recommendations

The TPS63070 device family has no special requirements for its power supply. The power supply output current needs to be rated according to the supply voltage, output voltage and output current of TPS63070. Please see the layout guidelines about the placement of the external components.

10.1 Thermal Information

Implementation of integrated circuits in low-profile and fine-pitch surface-mount packages typically requires special attention to power dissipation. Many system-dependent issues such as thermal coupling, airflow, added heat sinks and convection surfaces, and the presence of other heat-generating components affect the power-dissipation limits of a given component.

Three basic approaches for enhancing thermal performance are listed below.

- Improving the power dissipation capability of the PCB design
- Improving the thermal coupling of the component to the PCB by soldering the PowerPAD™
- Introducing airflow in the system

For more details on how to use the thermal parameters in the dissipation ratings table please check the [Thermal Characteristics Application Note \(SZZA017\)](#) and the [IC Package Thermal Metrics Application Note \(SPRA953\)](#).

11 Layout

11.1 Layout Guidelines

For all switching power supplies, the layout is an important step in the design, especially at high peak currents and high switching frequencies. If the layout is not carefully done, the regulator could show stability problems as well as EMI problems. Therefore, use wide and short traces for the main current path and for the power ground connection. The input capacitor, output capacitor, and the inductor should be placed as close as possible to the IC. Use a common ground node for power ground and a different one for control ground to minimize the effects of ground noise. Connect these ground nodes at any place close to one of the ground pin of the IC.

A ceramic capacitor each, as close as possible from the VIN pin to GND and one from the VOUT pin to GND, shown as C1 and C4 in the layout proposal are used to suppress high frequency noise. The case size should be 0603 or smaller for good high frequency performance. Additional 0805 size input and output capacitors are used to get the required capacitance on the input and output depending on the supply voltage range and the output voltage.

The feedback divider should be placed as close as possible to the feedback pin of the IC. To lay out the control ground, short traces are recommended as well, separation from the power ground traces. This avoids ground shift problems, which can occur due to superimposition of power ground current and control ground current.

In case any of the digital inputs EN, VSEL or PS/SYNC need to be tied to the input supply voltage VIN, a 10k resistor must be used in series. One common resistor for all digital inputs that are tied to VIN is sufficient.

11.2 Layout Example

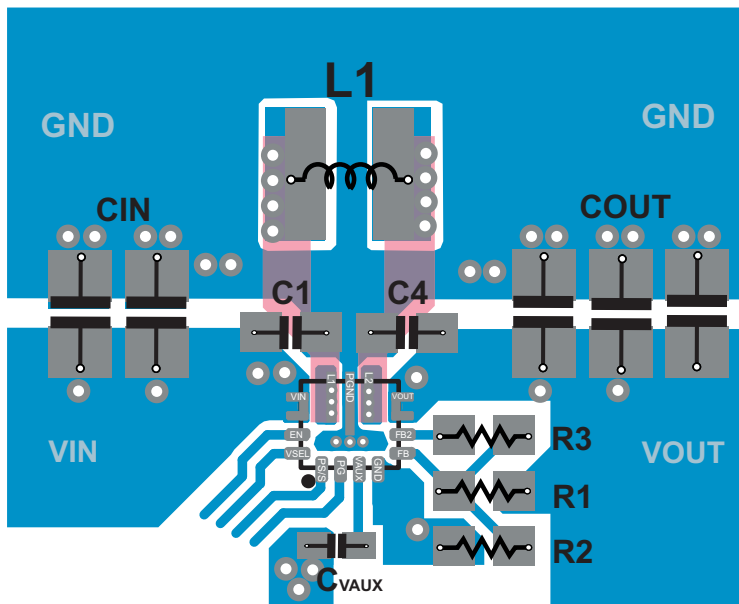

Figure 49. EVM Layout

12 Device and Documentation Support

12.1 Device Support

12.1.1 Third-Party Products Disclaimer

TI'S PUBLICATION OF INFORMATION REGARDING THIRD-PARTY PRODUCTS OR SERVICES DOES NOT CONSTITUTE AN ENDORSEMENT REGARDING THE SUITABILITY OF SUCH PRODUCTS OR SERVICES OR A WARRANTY, REPRESENTATION OR ENDORSEMENT OF SUCH PRODUCTS OR SERVICES, EITHER ALONE OR IN COMBINATION WITH ANY TI PRODUCT OR SERVICE.

12.2 Related Links

The table below lists quick access links. Categories include technical documents, support and community resources, tools and software, and quick access to sample or buy.

Table 8. Related Links

PARTS	PRODUCT FOLDER	SAMPLE & BUY	TECHNICAL DOCUMENTS	TOOLS & SOFTWARE	SUPPORT & COMMUNITY
TPS63070	Click here	Click here	Click here	Click here	Click here
TPS630701	Click here	Click here	Click here	Click here	Click here

12.3 Receiving Notification of Documentation Updates

To receive notification of documentation updates, navigate to the device product folder on ti.com. In the upper right corner, click on *Alert me* to register and receive a weekly digest of any product information that has changed. For change details, review the revision history included in any revised document.

12.4 Community Resources

The following links connect to TI community resources. Linked contents are provided "AS IS" by the respective contributors. They do not constitute TI specifications and do not necessarily reflect TI's views; see TI's [Terms of Use](#).

TI E2E™ Online Community *TI's Engineer-to-Engineer (E2E) Community*. Created to foster collaboration among engineers. At e2e.ti.com, you can ask questions, share knowledge, explore ideas and help solve problems with fellow engineers.

Design Support *TI's Design Support* Quickly find helpful E2E forums along with design support tools and contact information for technical support.

12.5 Trademarks

E2E is a trademark of Texas Instruments.
All other trademarks are the property of their respective owners.

12.6 Electrostatic Discharge Caution



This integrated circuit can be damaged by ESD. Texas Instruments recommends that all integrated circuits be handled with appropriate precautions. Failure to observe proper handling and installation procedures can cause damage.

ESD damage can range from subtle performance degradation to complete device failure. Precision integrated circuits may be more susceptible to damage because very small parametric changes could cause the device not to meet its published specifications.

12.7 Glossary

[SLYZ022](#) — *TI Glossary*.

This glossary lists and explains terms, acronyms, and definitions.

13 Mechanical, Packaging, and Orderable Information

The following pages include mechanical, packaging, and orderable information. This information is the most current data available for the designated devices. This data is subject to change without notice and revision of this document. For browser-based versions of this data sheet, refer to the left-hand navigation.

PACKAGING INFORMATION

Orderable Device	Status (1)	Package Type	Package Drawing	Pins	Package Qty	Eco Plan (2)	Lead/Ball Finish (6)	MSL Peak Temp (3)	Op Temp (°C)	Device Marking (4/5)	Samples
TPS630701RNMR	ACTIVE	VQFN-HR	RNM	15	3000	Green (RoHS & no Sb/Br)	CU NIPDAU	Level-1-260C-UNLIM		0701	Samples
TPS630701RNMT	ACTIVE	VQFN-HR	RNM	15	250	Green (RoHS & no Sb/Br)	CU NIPDAU	Level-1-260C-UNLIM		0701	Samples
TPS63070RNMR	ACTIVE	VQFN-HR	RNM	15	3000	Green (RoHS & no Sb/Br)	CU NIPDAU	Level-1-260C-UNLIM		3070	Samples
TPS63070RNMT	ACTIVE	VQFN-HR	RNM	15	250	TBD	Call TI	Call TI		3070	Samples

(1) The marketing status values are defined as follows:

ACTIVE: Product device recommended for new designs.

LIFEBUY: TI has announced that the device will be discontinued, and a lifetime-buy period is in effect.

NRND: Not recommended for new designs. Device is in production to support existing customers, but TI does not recommend using this part in a new design.

PREVIEW: Device has been announced but is not in production. Samples may or may not be available.

OBSELETE: TI has discontinued the production of the device.

(2) Eco Plan - The planned eco-friendly classification: Pb-Free (RoHS), Pb-Free (RoHS Exempt), or Green (RoHS & no Sb/Br) - please check <http://www.ti.com/productcontent> for the latest availability information and additional product content details.

TBD: The Pb-Free/Green conversion plan has not been defined.

Pb-Free (RoHS): TI's terms "Lead-Free" or "Pb-Free" mean semiconductor products that are compatible with the current RoHS requirements for all 6 substances, including the requirement that lead not exceed 0.1% by weight in homogeneous materials. Where designed to be soldered at high temperatures, TI Pb-Free products are suitable for use in specified lead-free processes.

Pb-Free (RoHS Exempt): This component has a RoHS exemption for either 1) lead-based flip-chip solder bumps used between the die and package, or 2) lead-based die adhesive used between the die and leadframe. The component is otherwise considered Pb-Free (RoHS compatible) as defined above.

Green (RoHS & no Sb/Br): TI defines "Green" to mean Pb-Free (RoHS compatible), and free of Bromine (Br) and Antimony (Sb) based flame retardants (Br or Sb do not exceed 0.1% by weight in homogeneous material)

(3) MSL, Peak Temp. - The Moisture Sensitivity Level rating according to the JEDEC industry standard classifications, and peak solder temperature.

(4) There may be additional marking, which relates to the logo, the lot trace code information, or the environmental category on the device.

(5) Multiple Device Markings will be inside parentheses. Only one Device Marking contained in parentheses and separated by a "~" will appear on a device. If a line is indented then it is a continuation of the previous line and the two combined represent the entire Device Marking for that device.

(6) Lead/Ball Finish - Orderable Devices may have multiple material finish options. Finish options are separated by a vertical ruled line. Lead/Ball Finish values may wrap to two lines if the finish value exceeds the maximum column width.

Important Information and Disclaimer: The information provided on this page represents TI's knowledge and belief as of the date that it is provided. TI bases its knowledge and belief on information provided by third parties, and makes no representation or warranty as to the accuracy of such information. Efforts are underway to better integrate information from third parties. TI has taken and continues to take reasonable steps to provide representative and accurate information but may not have conducted destructive testing or chemical analysis on incoming materials and chemicals. TI and TI suppliers consider certain information to be proprietary, and thus CAS numbers and other limited information may not be available for release.

In no event shall TI's liability arising out of such information exceed the total purchase price of the TI part(s) at issue in this document sold by TI to Customer on an annual basis.

TAPE AND REEL INFORMATION



QUADRANT ASSIGNMENTS FOR PIN 1 ORIENTATION IN TAPE



*All dimensions are nominal

Device	Package Type	Package Drawing	Pins	SPQ	Reel Diameter (mm)	Reel Width W1 (mm)	A0 (mm)	B0 (mm)	K0 (mm)	P1 (mm)	W (mm)	Pin1 Quadrant
TPS630701RNMR	VQFN-HR	RNM	15	3000	330.0	12.4	2.8	3.3	1.2	8.0	12.0	Q1
TPS630701RNMT	VQFN-HR	RNM	15	250	180.0	12.4	2.8	3.3	1.2	8.0	12.0	Q1
TPS63070RNMR	VQFN-HR	RNM	15	3000	330.0	12.4	2.8	3.3	1.2	8.0	12.0	Q1

TAPE AND REEL BOX DIMENSIONS

*All dimensions are nominal

Device	Package Type	Package Drawing	Pins	SPQ	Length (mm)	Width (mm)	Height (mm)
TPS630701RNMR	VQFN-HR	RNM	15	3000	367.0	367.0	35.0
TPS630701RNMT	VQFN-HR	RNM	15	250	210.0	185.0	35.0
TPS63070RNMR	VQFN-HR	RNM	15	3000	367.0	367.0	35.0

EXAMPLE BOARD LAYOUT

RNM0015A

VQFN - 1 mm max height

PLASTIC QUAD FLATPACK - NO LEAD

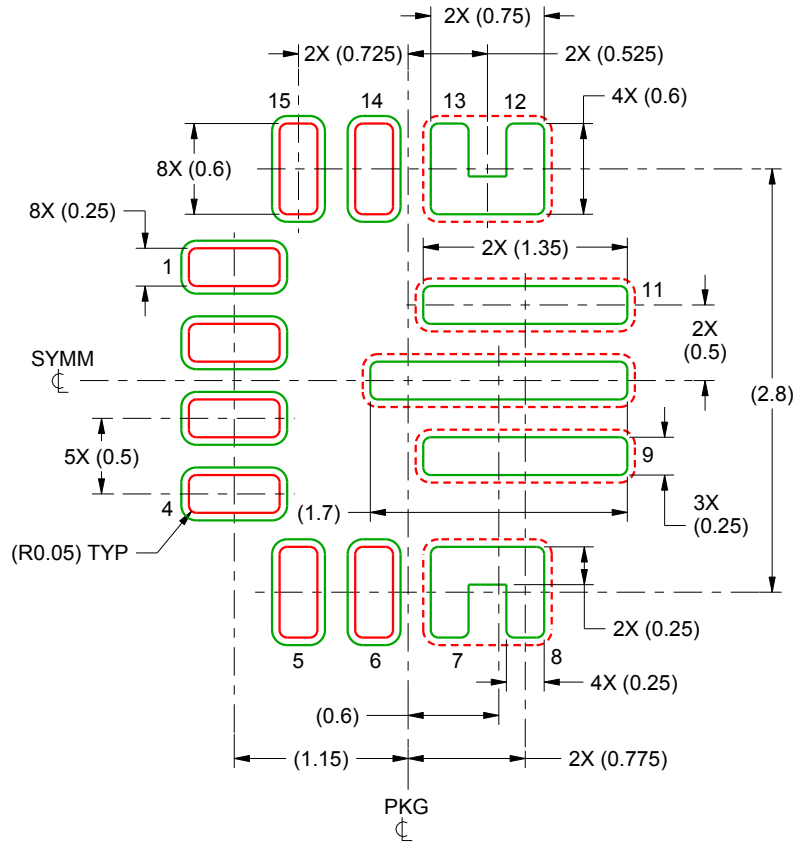

LAND PATTERN EXAMPLE
SCALE:20X

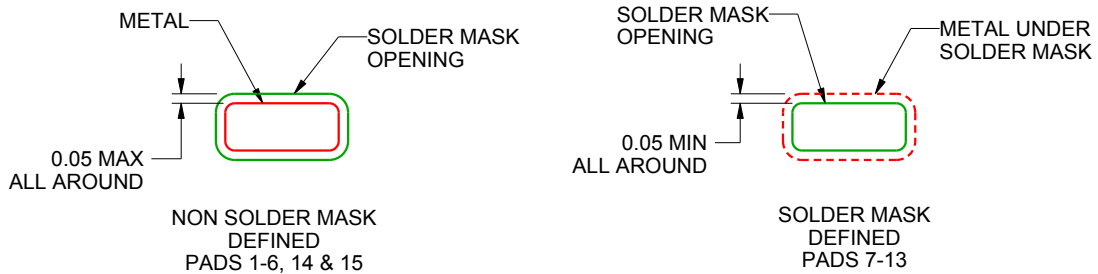

SOLDER MASK DETAILS

4222000/A 07/2015

NOTES: (continued)

3. For more information, see Texas Instruments literature number SLUA271 (www.ti.com/lit/sluea271).
4. Solder mask tolerances between and around signal pads can vary based on board fabrication site.

EXAMPLE STENCIL DESIGN

RNM0015A

VQFN - 1 mm max height

PLASTIC QUAD FLATPACK - NO LEAD

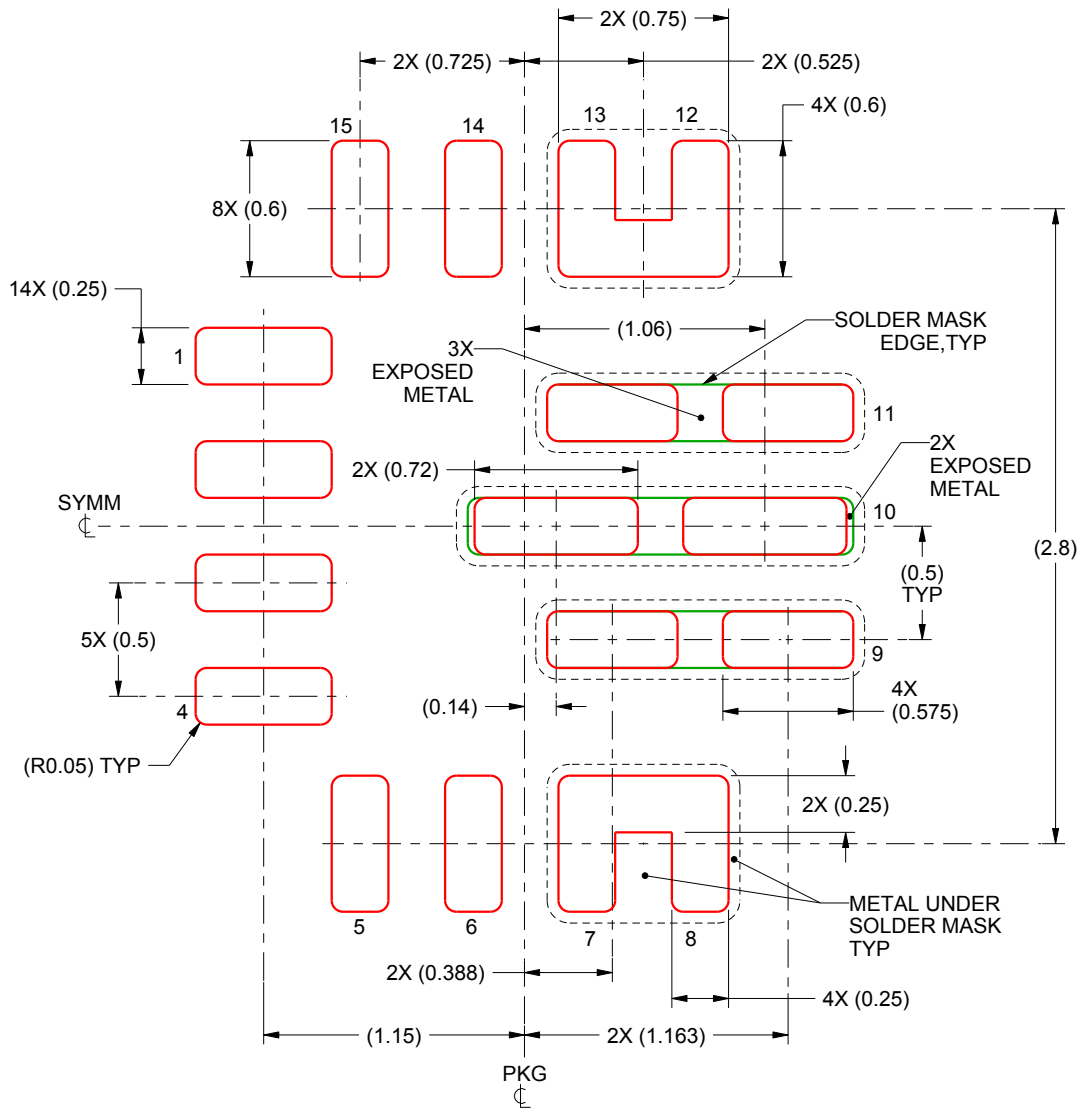

4222000/A 07/2015

NOTES: (continued)

5. For alternate stencil design recommendations, see IPC-7525 or board assembly site preference.

IMPORTANT NOTICE

Texas Instruments Incorporated and its subsidiaries (TI) reserve the right to make corrections, enhancements, improvements and other changes to its semiconductor products and services per JESD46, latest issue, and to discontinue any product or service per JESD48, latest issue. Buyers should obtain the latest relevant information before placing orders and should verify that such information is current and complete. All semiconductor products (also referred to herein as "components") are sold subject to TI's terms and conditions of sale supplied at the time of order acknowledgment.

TI warrants performance of its components to the specifications applicable at the time of sale, in accordance with the warranty in TI's terms and conditions of sale of semiconductor products. Testing and other quality control techniques are used to the extent TI deems necessary to support this warranty. Except where mandated by applicable law, testing of all parameters of each component is not necessarily performed.

TI assumes no liability for applications assistance or the design of Buyers' products. Buyers are responsible for their products and applications using TI components. To minimize the risks associated with Buyers' products and applications, Buyers should provide adequate design and operating safeguards.

TI does not warrant or represent that any license, either express or implied, is granted under any patent right, copyright, mask work right, or other intellectual property right relating to any combination, machine, or process in which TI components or services are used. Information published by TI regarding third-party products or services does not constitute a license to use such products or services or a warranty or endorsement thereof. Use of such information may require a license from a third party under the patents or other intellectual property of the third party, or a license from TI under the patents or other intellectual property of TI.

Reproduction of significant portions of TI information in TI data books or data sheets is permissible only if reproduction is without alteration and is accompanied by all associated warranties, conditions, limitations, and notices. TI is not responsible or liable for such altered documentation. Information of third parties may be subject to additional restrictions.

Resale of TI components or services with statements different from or beyond the parameters stated by TI for that component or service voids all express and any implied warranties for the associated TI component or service and is an unfair and deceptive business practice. TI is not responsible or liable for any such statements.

Buyer acknowledges and agrees that it is solely responsible for compliance with all legal, regulatory and safety-related requirements concerning its products, and any use of TI components in its applications, notwithstanding any applications-related information or support that may be provided by TI. Buyer represents and agrees that it has all the necessary expertise to create and implement safeguards which anticipate dangerous consequences of failures, monitor failures and their consequences, lessen the likelihood of failures that might cause harm and take appropriate remedial actions. Buyer will fully indemnify TI and its representatives against any damages arising out of the use of any TI components in safety-critical applications.

In some cases, TI components may be promoted specifically to facilitate safety-related applications. With such components, TI's goal is to help enable customers to design and create their own end-product solutions that meet applicable functional safety standards and requirements. Nonetheless, such components are subject to these terms.

No TI components are authorized for use in FDA Class III (or similar life-critical medical equipment) unless authorized officers of the parties have executed a special agreement specifically governing such use.

Only those TI components which TI has specifically designated as military grade or "enhanced plastic" are designed and intended for use in military/aerospace applications or environments. Buyer acknowledges and agrees that any military or aerospace use of TI components which have **not** been so designated is solely at the Buyer's risk, and that Buyer is solely responsible for compliance with all legal and regulatory requirements in connection with such use.

TI has specifically designated certain components as meeting ISO/TS16949 requirements, mainly for automotive use. In any case of use of non-designated products, TI will not be responsible for any failure to meet ISO/TS16949.

Products

Audio	www.ti.com/audio
Amplifiers	amplifier.ti.com
Data Converters	dataconverter.ti.com
DLP® Products	www.dlp.com
DSP	dsp.ti.com
Clocks and Timers	www.ti.com/clocks
Interface	interface.ti.com
Logic	logic.ti.com
Power Mgmt	power.ti.com
Microcontrollers	microcontroller.ti.com
RFID	www.ti-rfid.com
OMAP Applications Processors	www.ti.com/omap
Wireless Connectivity	www.ti.com/wirelessconnectivity

Applications

Automotive and Transportation	www.ti.com/automotive
Communications and Telecom	www.ti.com/communications
Computers and Peripherals	www.ti.com/computers
Consumer Electronics	www.ti.com/consumer-apps
Energy and Lighting	www.ti.com/energy
Industrial	www.ti.com/industrial
Medical	www.ti.com/medical
Security	www.ti.com/security
Space, Avionics and Defense	www.ti.com/space-avionics-defense
Video and Imaging	www.ti.com/video

TI E2E Community

e2e.ti.com