

LTC3350EUHF

High Current Supercapacitor Backup Controller and System Monitor

DESCRIPTION

Demonstration circuit 1937B is a supercapacitor charger and backup controller with supercapacitor health and system monitoring; featuring the **LTC®3350**. The LTC3350 has a buck supercapacitor charger, backup boost controller and an input ideal diode to disconnect the input supply in backup mode. An output ideal diode allows the supercapacitors to supply the output when VCAP is above the set backup voltage. As the capacitor stack voltage drops

down to the set output voltage, the LTC3350 will operate as a boost regulator to supply the output until the energy in the supercapacitors are depleted.

Design files for this circuit board are available at <http://www.linear.com/demo/DC1937B>

LT, LT, LTC, LTM, Linear Technology and the Linear logo are registered trademarks and QuikEval is a trademark of Linear Technology Corporation. All other trademarks are the property of their respective owners.

PERFORMANCE SUMMARY Specifications are at T_A = 25°C

PARAMETER	CONDITIONS	MIN	TYP	MAX	UNITS
Input Supply Range		10.8	12	20	V
Input Current Limit			2		A
V _{OUT} Backup Operating Voltage	Boost Mode		6		V
V _{CAP} Float Voltage	Buck Mode		10		V
Max Charge Current			5.33		A
t _{BACKUP}	P _{BACKUP} = 25W, I _{BOOST} = 9.67A, 3 ≤ V _{CAP} ≤ 10		3.2		s

BOARD PHOTO

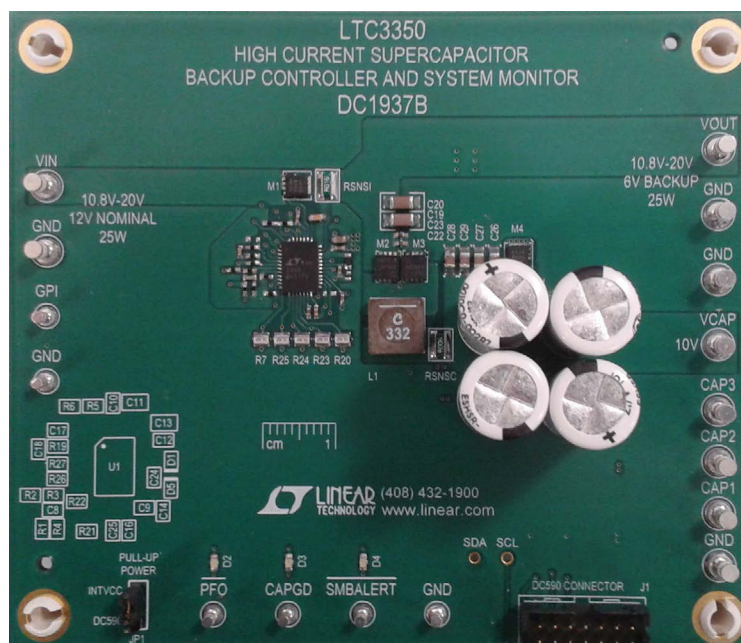

TYPICAL APPLICATION

High Current Supercapacitor Charger and Backup Supply

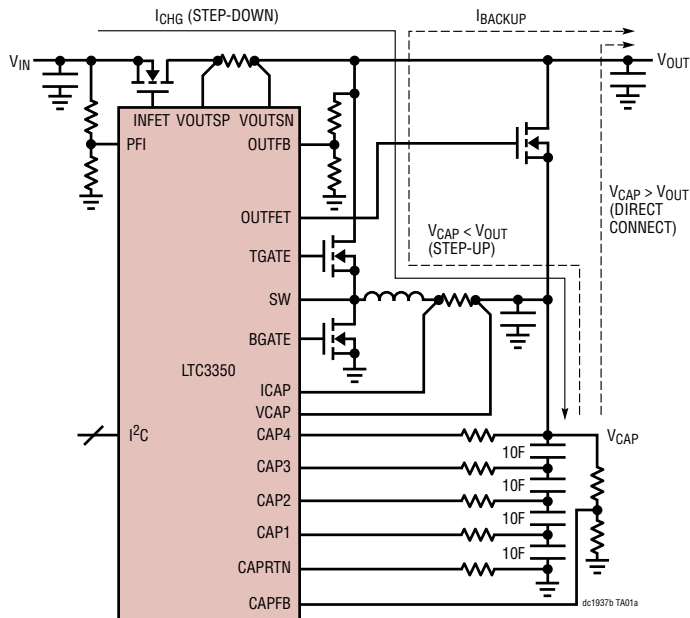

Backup Operation

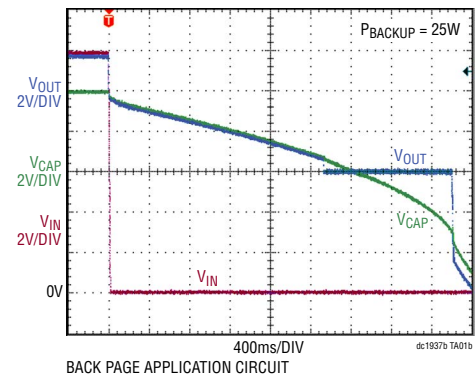

QUICK START PROCEDURE

Obtain and connect a DC590B board to the DC1937B board. Using short twisted pair leads for the power connections and with the LOAD and the power supply OFF. Refer to Figure 1 and Figure 2 for the proper measurement and equipment setup. Follow the procedure below.

1. Refer to the DC590B Quick Start Guide for QuikEval™ setup and software installation details.
2. Make sure the USB cable is connected between the computer and the DC590B controller board.
3. Connect a 14-pin ribbon cable from the DC590B board to the DC1937B board.
4. Set the VCCIO jumper, JP6, on the DC590B board to the 5V position.
5. Set the JP1 jumper on the DC1937B board to the DC590 position.
6. Start the Linear Technology QuikEval program. This program should automatically detect the presence of the LTC3350 demo board (DC1937B) and activate the appropriate GUI, as seen in Figure 5.

7. With power off, connect a 0V to 20V, 25W supply between the VIN and GND terminals with a series ammeter and a voltmeter as shown in Figure 1.
8. Turn on and set the VIN input power supply to 12V and observe the CAP voltages, input and charge current on the GUI.

NOTE. Make sure that the input voltage does not exceed 20V.

NOTE. The LTC3350 is intended to operate with a low impedance source. If operating near the PFI rising threshold, make sure the input voltage does not drop more than $30\text{mV} \cdot (R5 + R6)/R6$, 266mV, during a charge event.

9. On the LTC3350 Control Window, click on the CAP and ESR Measurement START button. An In Process indicator displays while the measurement is in process.

NOTE. Supercapacitors initially have large leakage currents which causes the capacitance measurement to be low. The capacitor measurements will be more accurate after the 10F capacitors have been continuously charged for more than 30 minutes.

dc1937bfa

QUICK START PROCEDURE

10. Connect a 0W to 25W constant power load box between VOUT and GND and set to 25W.
11. Connect an oscilloscope probe each to VIN, VOUT, VCAP and PFO. Set the oscilloscope to trigger on the falling edge of PFO.
12. Remove the input power and observe how the output drops to the regulation point and is maintained until the energy in the supercapacitors are exhausted.
13. The LTC3350 has the ability to monitor and report on the supercapacitor and system voltages, currents, die temperature and capacitor health. See the software section and data sheet for more information.
14. The DC1937B can be modified to operate at different frequencies, operating voltages, input and boost currents. The Hardware Config tab allows the user to enter the appropriate changes so the GUI can report the correct measurements. See the Software section for more details.

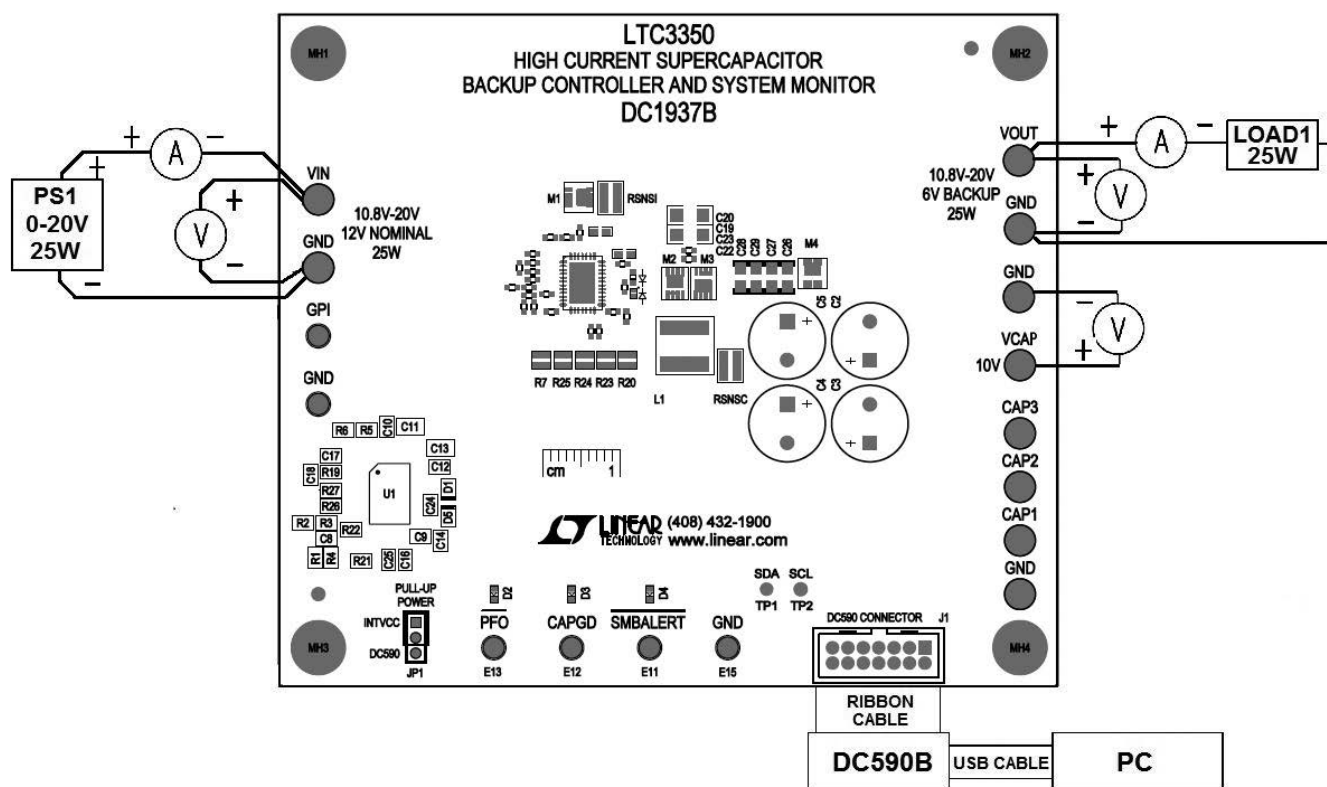

Figure 1. Proper Measurement Equipment Setup

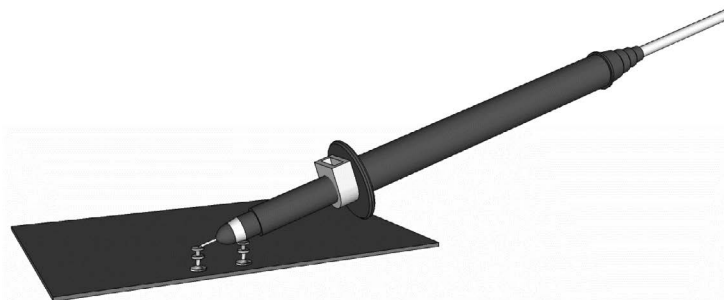

Figure 2. Measuring Input or Output Ripple

APPLICATION INFORMATION

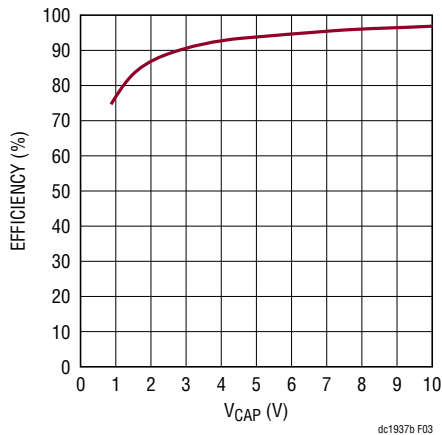

Figure 3. Charger Efficiency

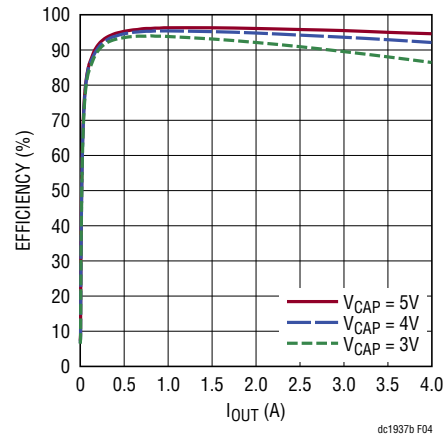

Figure 4. Boost Efficiency

The DC1937B was designed to provide 25W of power for a total of 1.8 seconds with a backup voltage of 6V. It was also determined that the maximum life expectancy of this product is six years with a maximum ambient temperature of 45°C. When choosing the capacitance needed the condition of the supercapacitor at end of life (EOL) needs to be considered. EOL is typically when the capacitance decreases by 30% and when the ESR doubles. With this knowledge and a few calculations the capacitors needed for this application can be chosen. Refer to the LTC3350 data sheet for more details on the formulas used in the following examples.

Since the backup time and backup power are known, the next item that needs to be determined is the maximum voltage to be applied to the capacitor $V_{CELL(MAX)}$ to provide the maximum life expectancy for the application. Refer to the capacitor manufacturer's data sheet for this information. A $V_{CELL(MAX)}$ of 2.5V was chosen for the 6 year life expectancy of this product.

The number of capacitors in the stack also needs to be chosen plus the Utilization Factor (α_B). α_B is the amount of energy in the capacitor to be used for backup. A typical α_B is 80%, but a conservative α_B of 70% was used on the DC1937B. The minimum capacitance required for

each capacitor in the stack at EOL can be calculated by the following equation:

$$C_{EOL} \geq \frac{4P_{BACKUP} \cdot t_{BACKUP}}{n\eta V_{CELL(MAX)}^2} \cdot \left[\alpha_B + \sqrt{\alpha_B} - (1 - \alpha_B) \ln \left(\frac{1 + \sqrt{\alpha_B}}{\sqrt{1 - \alpha_B}} \right) \right]^{-1}$$

Where η represents the boost efficiency, n represents the number of capacitors in the stack. Based on an efficiency of 90% and the backup requirements, the minimum C_{EOL} is calculated as:

$$C_{EOL} \geq \frac{4 \cdot 25W \cdot 1.8s}{4 \cdot 0.9 \cdot (2.5V)^2} \cdot \left[0.7 + \sqrt{0.7} - (1 - 0.7) \ln \left(\frac{1 + \sqrt{0.7}}{\sqrt{1 - 0.7}} \right) \right]^{-1} = 6.816F$$

The maximum capacitor ESR at end of life can then be determined below:

$$ESR_{EOL} \leq \frac{\eta(1 - \alpha_B)nV_{CELL(MAX)}^2}{4P_{BACKUP}}$$

APPLICATION INFORMATION

The capacitor ESR_{EOL} is determined below:

$$ESR_{EOL} \leq \frac{0.9(1-0.7) \cdot 4 \cdot (2.5V)^2}{4 \cdot 25W} = 67.5m\Omega$$

Now the EOL parameters are known, the capacitor can be chosen based on the manufacture's capacitor specification for EOL. For the DC1937B, the NESSCAP ESHSR-0010C0-002R7 was chosen with a C_{EOL} of 7F, an ESR_{EOL} of 64m Ω and a maximum current of 10.1A.

To verify the capacitors are adequate at EOL we first need to determine the minimum stack voltage ($V_{STK(MIN)}$) at EOL. $V_{STK(MIN)}$ will be limited by either the maximum power transfer rule or by current limit, whichever is greater. The minimum capacitor voltage due to the maximum power transfer rule can be calculated with the following formula:

$$V_{STK(MIN)} = \sqrt{\frac{4 \cdot ESR_{EOL} \cdot n \cdot P_{BACKUP}}{\eta}}$$

$V_{STK(MIN)}$ is the maximum stack voltage ($n \cdot V_{CELL}$). The desired $V_{STK(MIN)}$ due to the maximum power transfer rule is calculated as:

$$\sqrt{\frac{4 \cdot 4 \cdot 64m\Omega \cdot 25W}{0.9}} = 5.333V$$

$V_{STK(MIN)}$ can also be determined by the current limit and the ESR_{EOL} as shown in the following equation:

$$V_{STK(MIN)} = \frac{P_{BACKUP}}{\eta I_{LMAX}} + nESR_{EOL} I_{LMAX}$$

Where I_{LMAX} is the boost peak current limit. The EOL $V_{STK(MIN)}$ based on boost peak current limit is calculated below:

$$\frac{25W}{0.9 \cdot 9.67A} + 4 \cdot 64m\Omega \cdot 9.67A = 5.348V$$

Now $V_{STK(MIN)}$ at EOL is known, the $V_{STK(MIN)}$ can be rearranged to calculate actual α_B at EOL. The calculated $V_{STK(MIN)}$ can also be used to determine if the chosen

capacitor will be sufficient for worst case EOL conditions, when both ESR_{EOL} and C_{EOL} have been reached.

$$t_{BACKUP} = \frac{\eta C_{STK}}{4P_{BACKUP}} \cdot$$

$$\left[\gamma_{(MAX)} V_{(STK(MAX))}^2 - \gamma_{(MIN)} V_{(STK(MIN))}^2 - V_{LOSS}^2 \right]$$

Where C_{STK} is the total stack capacitance, $V_{STK(MIN)}$ is based on the higher calculated $V_{STK(MIN)}$,

$$\gamma_{(MAX)} = 1 + \sqrt{1 - \frac{4nESR_{EOL} \cdot P_{BACKUP}}{\eta V_{STK(MAX)}^2}}$$

$$\gamma_{(MIN)} = 1 + \sqrt{1 - \frac{4nESR_{EOL} \cdot P_{BACKUP}}{V_{STK(MIN)}^2}} \text{ and}$$

$$V_{LOSS}^2 = \frac{4nESR_{EOL} P_{BACKUP}}{\eta} \ln \left(\frac{\gamma_{(MAX)} V_{STK(MAX)}}{\gamma_{(MIN)} V_{STK(MIN)}} \right)$$

The worst case EOL backup time is calculated below:

$$\gamma_{(MAX)} = 1 + \sqrt{1 - \frac{4 \cdot 4 \cdot 64m\Omega \cdot 25W}{0.9 \cdot (10V)^2}} = 1.8459$$

$$\gamma_{(MIN)} = 1 + \sqrt{1 - \frac{4 \cdot 4 \cdot 64m\Omega \cdot 25W}{0.9 \cdot (5.348V)^2}} = 1.0740$$

$$V_{LOSS}^2 = \frac{4 \cdot 4 \cdot 64m\Omega \cdot 25W}{0.9} \cdot$$

$$\ln \left(\frac{1.8459 \cdot 10V}{1.0740 \cdot 5.348V} \right) = 33.207V^2$$

$$t_{BACKUP} = \frac{0.9 \cdot \left(\frac{7}{4} \right) F}{4 \cdot 25W} \cdot$$

$$\left[1.846 \cdot (10V)^2 - 1.074 \cdot (5.348V)^2 - 33.207V^2 \right] = 1.9s$$

The above results show that if both ESR_{EOL} and C_{EOL} are reached then the backup requirement will be met. If the backup requirement was not met, then a capacitor with lower ESR and/or more capacitance should be chosen.

USING THE LTC3350 SOFTWARE

The LTC3350 program provides the ability to measure and monitor the system voltages and currents plus the health of the supercapacitors. It also allows the user to set up alarms to report on specific events such as power fail or cap measurement done. Refer to Figure 5 for an illustration of the LTC3350 control window.

VIEW LTC3350 PRODUCT PAGE button opens an Internet browser and searches the Linear Technology Corporation website for information on the LTC3350 when an Internet connection is available.

CAP and ESR Measurement START button starts a capacitor and ESR measurement. An indicator below the START button indicates the status of the capacitor/ESR measurement. The different states are; In Process, Done, Pending or Failed.

Number of Caps Selected text box indicates the number of capacitors selected using the CAP_SLCTx pins.

SMBALERT Detected indicator indicates if an SMBALERT has been detected or not.

Clear SMBUS ALERT button sends an SMBus alert response address to clear the SMBALERT. Note, the condition that caused the SMBALERT must be cleared before the SMBALERT signal can be cleared.

CAP text box indicates the latest measured capacitance in Farads for large capacitors and mF for smaller capacitors. This measurement is based on the CAP scale setting in the control register plus the Current and Oscillator Resistor Settings on the Hardware Config tab.

ESR text box indicates the latest measured ESR in mΩ.

VCAP text box indicates the latest VCAP voltage in Volts.

ICHRG text box indicates the latest measured charge/boost current in amps. This measurement is based on the RSNSC setting on the Hardware Config tab.

VCAPx text box indicates the latest measured capacitor voltage in Volts for the corresponding VCAP.

VIN text box indicates the latest measured input voltage in Volts.

IIN text box indicates the latest measured input current in amps. This measurement is based on the RSNSI setting on the Hardware Config tab.

VOUT text box indicates the latest measured VOUT in Volts.

GPImon text box indicates the latest measured GPI voltage in Volts. An internal buffer can be enabled for measuring high impedance inputs.

Die Temp text box displays the latest internally measured die temperature in °C.

Register text boxes displays the associated register values in hexadecimal format.

Read Values button causes the LTC3350 to read all of the ADC measured values. This is useful when the LTC3350 GUI “Auto Update” is disabled.

Auto Update Enable/Disable button causes the LTC3350 to read all of the LTC3350 registers periodically and writes to any register changed when enabled. The Read Values, Read All, or Update All buttons can be used instead to update the registers when in the disabled state.

Read All button causes the LTC3350 to read all of the LTC3350 registers. This is useful when the LTC3350 GUI Auto Update is disabled.

CHARGER CONTROL TAB

The Charger Control tab contains the indicators and controls for the capacitor charger and monitor plus the GPI buffer enable as shown in Figure 5.

Charger Status STATUS Bits indicates when the associated chrg_status register bits are set. See the data sheet from more information on these bits.

Charger Status Read text box displays the last read chrg_status register value in hexadecimal format.

CAP ESR Period text box allows the user to set a period in which the LTC3350 will perform a capacitance and ESR measurement. The text box is formatted in hours, minutes, and seconds. The LSB for the CAP ESR Period register is 10 seconds.

CAP ESR Period Write text box displays the value that will be or has been written to the cap_esr_period register value in hexadecimal format.

CAP ESR Period Read text box displays the last value read from the cap_esr_period register in hexadecimal format.

USING THE LTC3350 SOFTWARE

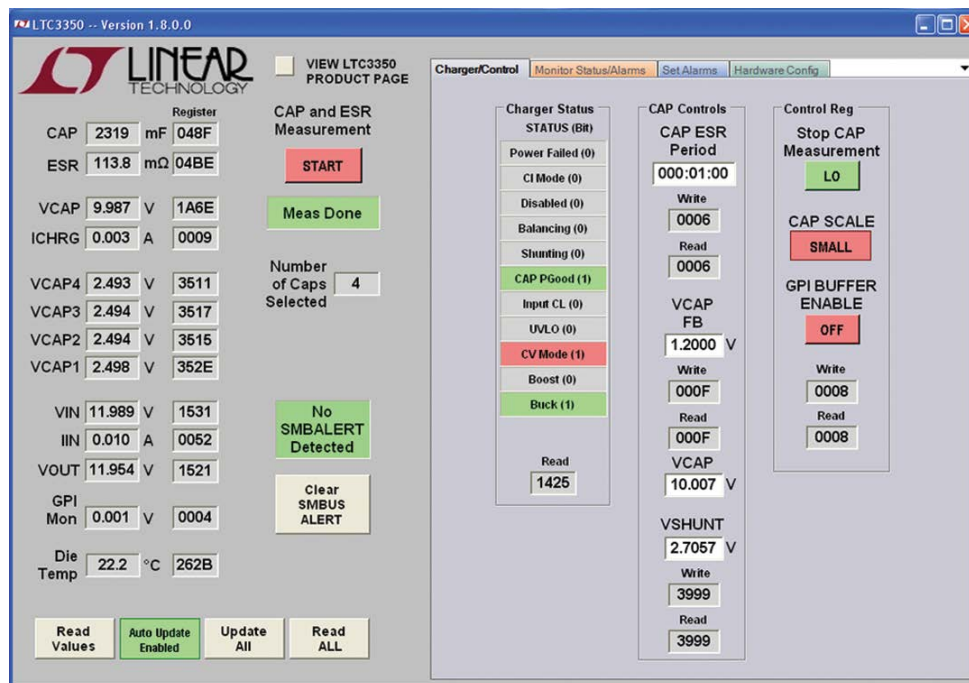

Figure 5. LTC3350 Control Window

VCAP FB text box allows the user to set the CAPFB reference voltage from 0.6375V to 1.2V in 37.5mV increments. The value in the text box is rounded to the nearest mV. The VCAP text box is also updated with the calculated value of the CAPFB reference voltage and the resistor network entered on the Hardware Config tab.

VCAP FB Write text box displays the value that will be or has been written to the vcapfb_dac register in hexadecimal format.

VCAP FB Read text box displays the last value read from the vcapfb_dac register in hexadecimal format.

VCAP text box allows the user to set the VCAP float voltage within the limits of the CAPFB reference voltage and the CAPFB resistor network on the Hardware Config tab. The value in the text box is rounded to the nearest mV. The VCAP FB text box is also updated with the calculated value using the CAPFB resistor network entered on the Hardware Config tab.

VSHUNT text box allows the user to set the shunt regulator voltage up to 3.6V or disable the shunt regulator. The shunt voltage will be reset to the default value of 2.7057 every time INTVCC is restored. Set VSHUNT to 0V to disable the shunt regulator.

VSHUNT Write text box displays the value that will be or has been written to the vshunt register in hexadecimal format.

VSHUNT Read text box displays the last value read from the vshunt register in hexadecimal format.

Stop CAP Measurement sets the ctl_stop_capesr bit in the ctl_reg register. This will cause any CAP/ESR measurement in process to stop. This bit will reset when the measurement has ceased.

CAP SCALE button sets the cap scale from large scale, default scale for larger capacitors, to small scale for smaller capacitors. The resolution is increased by 100x in small scale.

GPI BUFFER ENABLE button sets the ctl_gpi_buffer_en bit when enabling the GPI input buffer. When the GPI BUFFER ENABLE is off then the GPI input is measured without the input buffer.

Control Reg Write text box displays the value that will be or has been written to the ctl_reg register in hexadecimal format.

Control Reg Read text box displays the last value read from the ctl_reg register in hexadecimal format.

USING THE LTC3350 SOFTWARE

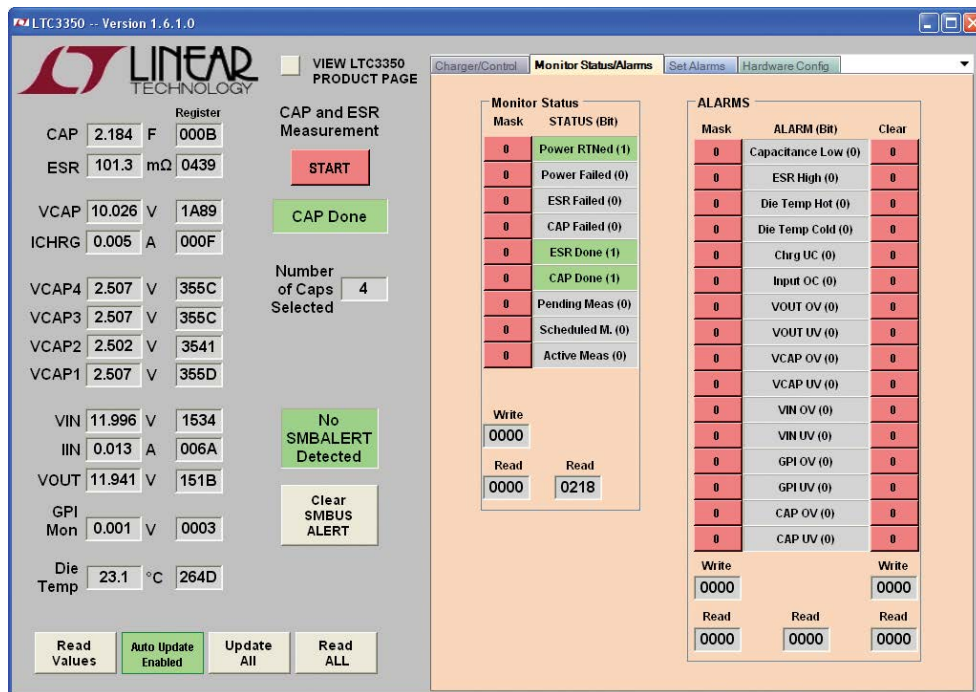

Figure 6. Monitor Status/Alarms Tab

MONITOR STATUS/ALARMS TAB

The Monitor Status/Alarms tab contains the indicators for the mon_status and alarm_reg bits plus control buttons for the Monitor Status Mask, Alarm Mask and Alarm Clear bits as shown in Figure 6.

Monitor Status STATUS Bits indicate when the associated mon_status register bits are set. See the data sheet from more information on these bits.

Monitor Status Read text box displays the last read mon_status register value in hexadecimal format.

Mask Monitor Status buttons will allow the rising edge of the associated monitor status bit to trigger the SMBALERT when the mask bit is set to 1.

Mask Mointor Write text box displays the value that will be or has been written to the msk_mon_status register in hexadecimal format.

Mask Monitor Read text box displays the last read msk_mon_status register value in hexadecimal format.

Alarm Bits indicate when the associated alarm_reg register bits are set. See the data sheet from more information on these bits.

Alarm Read text box displays the last read alarm_reg register value in hexadecimal format.

Mask Alarm buttons will allow the associated alarm bit to trigger the SMBALERT when the mask bit is set to 1.

Mask Alarm Write text box displays the value that will be or has been written to the msk_alarms register in hexadecimal format.

Mask Alarm Read text box displays the last read msk_alarms register value in hexadecimal format.

Clear Alarm buttons will cause the associated alarm to clear when the alarm condition no longer exists. The Clear alarm bit will reset low when the alarm is cleared.

Clear Alarm Write text box displays the value that will be or has been written to the clr_alarms register in hexadecimal format.

Clear Alarm Read text box displays the last read clr_alarms register value in hexadecimal format.

USING THE LTC3350 SOFTWARE

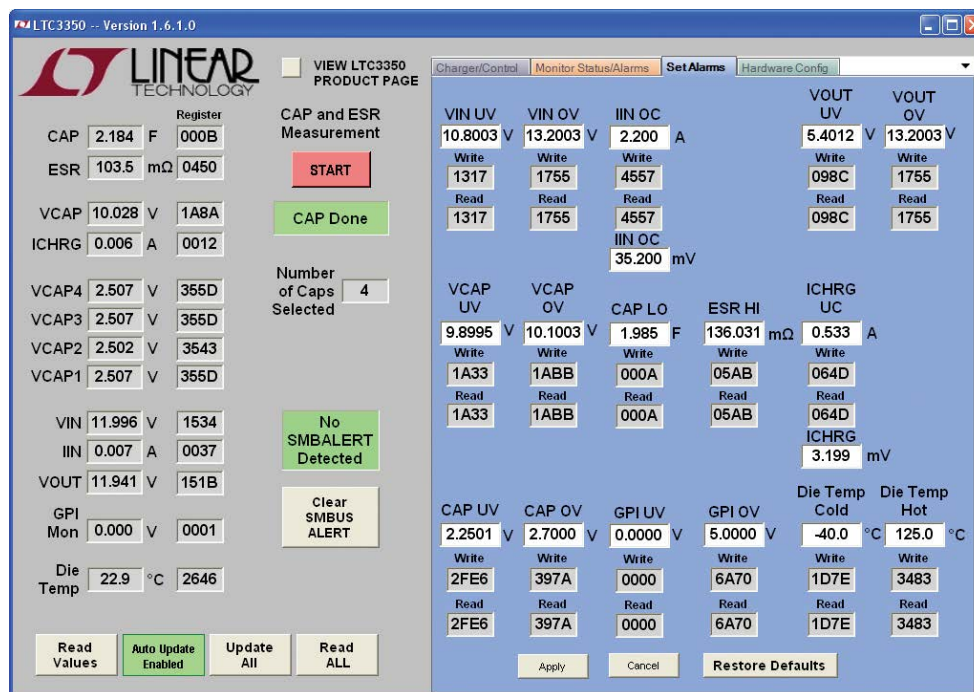

Figure 7. Set Alarms Tab

SET ALARMS TAB

The Set Alarms tab contains text boxes to allow the user to set specific levels for each alarm register as shown in Figure 7. Each alarm has an associated Write text box to display the value that will be or has been written to the associated register in hexadecimal format. Each alarm also has an associated Read text box which displays the last read contents of the associated register in hexadecimal format.

VIN/VOUT/VCAP/CAP/GPI UV alarm text boxes allow the user to enter a voltage that will trigger an alarm when the associated voltage drops below the entered voltage value and the associated alarm mask bit is set.

VIN/VOUT/VCAP/CAP/GPI OV alarm text boxes allow the user to enter a voltage that will trigger an alarm when the associated voltage rises above the entered voltage value and the associated alarm mask bit is set.

IIN OC alarm text boxes allow the user to enter a current or the voltage across the sense resistor that will trigger an alarm when the input current increase above the entered value and the msk_iin_oc alarm mask bit is set.

CAP LO alarm text box allows the user to enter a capacitance based on the current ctl_cap_scale setting in the ctl_reg. A CAP LO alarm will be triggered if the measured capacitance is lower than the entered value and the msk_cap_lo bit is set.

ESR HI alarm text box allows the user to enter an ESR value based on the RSNSC resistor value entered in the Hardware Config tab. An ESR HI alarm will be triggered if the measured ESR is higher than the entered value and the msk_esr_hi bit is set.

ICHRG UC alarm text boxes allow the user to enter a current or the voltage across the sense resistor that will trigger an alarm when the charge current decreases below the entered value and the msk_ichrg_lo bit is set.

Die Temp Cold alarm text box allows the user to enter a die temperature in °C that will trigger an alarm when the temperature decreases below the entered value and the msk_dtemp_cold bit is set.

Die Temp Hot alarm text box allows the user to enter a die temperature in °C that will trigger an alarm when the temperature increases above the entered value and the msk_dtemp_hot bit is set.

USING THE LTC3350 SOFTWARE

Apply button writes to all of the alarm registers and reads the values back from the LTC3350.

Cancel button changes all the entered values that have not yet been written to the LTC3350 back to their previous values.

Restore Defaults button changes all of the LTC3350 alarm registers back to the default values determined from the GUI. This does not set the alarm to the LTC3350's default settings of 0x0000.

HARDWARE CONFIG TAB

The Hardware Config tab, shown in Figure 8, contains text boxes to allow the user to enter the values to configure the necessary resistors to match the configuration of the demo board. These values are used by the GUI to calculate measured CAP and ESR values, display input/charge currents and max VCAP voltage for a given reference setting, and also used in the Set Alarm tab text boxes.

The screenshot shows the 'Hardware Config' tab with the following settings:

- VPFI Resistor Settings:**
 - VPFI Falling Setpoint: 10.378 V
 - Total error budget sensitivity the sum: 1.77 %
 - RTop: 787 K Ω , Error budget RTop tolerance sensitivity: 0.89 %
 - RBot: 100 K Ω , Error budget RBot tolerance sensitivity: 0.89 %
- VOUT Resistor Settings:**
 - VOUT Boost Setpoint: 6.007 V
 - Total error budget sensitivity the sum: 1.6 %
 - RTop: 649 K Ω , Error budget RTop tolerance sensitivity: 0.8 %
 - RBot: 162 K Ω , Error budget RBot tolerance sensitivity: 0.8 %
- Current and OSC Resistor Settings:**
 - RITST: 121 Ω , REXT: OPEN Ω , RT: 71.5 K
 - ITST: 9.92 mA, IEXT: 0 mA, FOSC: 748.3 KHz
 - Total RBalance: OPEN Ω , RSNSI: 16 m Ω , RSNSC: 6 m Ω
 - IBalance: 0 mA, IIN Max: 2 A, ICHRG Max: 5.33 A
 - I Test Total: 9.928 mA, IBoost Peak: 9.67 A
- VCAP Resistor Settings:**
 - VCAP Max Setpoint: 10.007 V
 - CAP1 Voltage Divider: CAP1 V
 - RTop: 866 K Ω , RTop: OPEN K Ω
 - RBot: 118 K Ω , RBot: OPEN K Ω

Figure 8. Hardware Config Tab

VPFI Resistor Settings text boxes allow the user to enter the PFI resistor divider network in k Ω . The calculated falling PFI threshold set point is displayed in Volts.

VOUT Resistor Settings text boxes allow the user to enter the VOUT resistor divider network in k Ω . The calculated VOUT backup set point is displayed in Volts.

RITST text box allows the user to enter the RITST resistor in Ω . The calculated test current setting is displayed in mA.

REXT text box allows the user to enter the external load resistance, R28 and R29, added in Ω if any. Enter -1 if there is not any external loading and OPEN will be displayed in the text box. See the Using Large Capacitor section for more details.

RT text box allows the user to enter the RT resistor in k Ω . The calculated oscillator setting is displayed in kHz.

Total RBalance text box allows the user to enter the equivalent total balance resistance in Ω if any for capacitance stacks or packs that have external balancing. Enter -1 if there is not any external balancing and OPEN will be displayed in the text box.

RSNSI text box allows the user to enter the RSNSI resistor in m Ω . The calculated input current limit setting is displayed in Amps.

RSNSC text box allows the user to enter the RSNSC resistor in m Ω . The calculated maximum charge current setting is displayed in Amps.

VCAP Resistor Settings text boxes allow the user to enter the CAPFB resistor divider network in k Ω . The calculated maximum VCAP set point is displayed in Volts.

CAP1 Voltage Divider text boxes allow the user to enter the CAP1 resistor divider network in k Ω if used. This is primarily used for the Zeta/SEPIC application (Data sheet Application Circuit 6). The displayed CAP1 voltage is calculated from the maximum VCAP voltage. Enter -1 in the CAP1 Voltage Divider RTop and RBot text boxes then OPEN will be displayed in both text boxes.

USING LARGE CAPACITORS

The DC1937B standard configuration is designed for supercapacitors of 50F or less. The standard configuration measures the time it takes to discharge the capacitor stack by 200mV at 10mA to calculate the capacitance. Larger supercapacitors have larger leakage currents, some over a milliamp, causing an inaccuracy in the capacitive measurement. To increase the measurement accuracy, the capacitor test current can be increased by loading the capacitor stack with external resistors, R28 and R29, during the measurement. The low threshold N-MOSFET, M6, is controlled by the ITST pin which turns on the load when needed.

OPTIONAL EXTERNAL TEST CURRENT

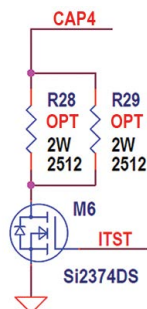

Figure 9. External Test Current

Larger capacitors also take longer to balance. If one capacitor is far enough off balance that it reaches the shunt voltage before the capacitor stack is fully charged. The charge current effectively is reduced to the shunt current until the capacitor stack is fully charged. The standard DC1937B board is set up for a 500mA maximum shunt current. This current can be increased by turning on external shunt resistors across each capacitor, R30 thru R36. The controlling FETs, M7 thru M10, are turned on from the voltage drop across the corresponding shunt resistor when the shunt regulator turns on. The 2.7Ω shunt resistors between the supercapacitor and the CAPx

pin as shown in Figure 10 can be used to provide a larger shunt current.

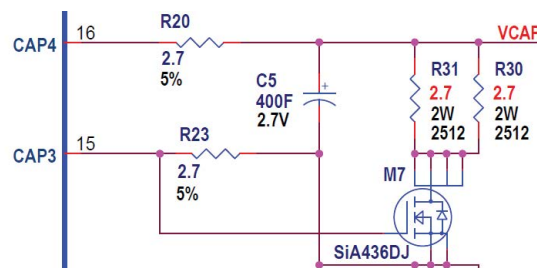

Figure 10. High Current Shunting

$$I_{SHUNT} = \frac{V_{SHUNT}}{2 \cdot R_{SHUNT}} + \frac{V_{SHUNT}}{R_{SHUNT(OPT)}}$$

The circuit in Figure 10 allows a larger shunt current to protect the capacitors and charge up to the maximum capacitor stack voltage faster but it does not increase the balancing current.

Having a larger balancing current will help keep the large capacitors in balance and may prevent the shunt voltage from being reached. It will also reduce the capacitor voltage from the shunt voltage faster after shunting stops and balancing begins. This is accomplished by increasing the shunt resistors from 2.7Ω to at least 250Ω and up to 1kΩ. Using resistors close to 250Ω will cause the balancing currents to be smaller, less than 10mA with capacitor voltages below 1.8V. Increasing the resistance much above 1kΩ can cause ADC measurement inaccuracies. The ITST resistor must be increased to 1MΩ or greater; 10MΩ if possible, to reduce the voltage drop across the CAP4 shunt resistor, R20, from the internal current source during the capacitance measurement. The circuit in Figure 11 provides up to a 2A shunt/balance current and a 200mA capacitor measurement test current.

USING LARGE CAPACITORS

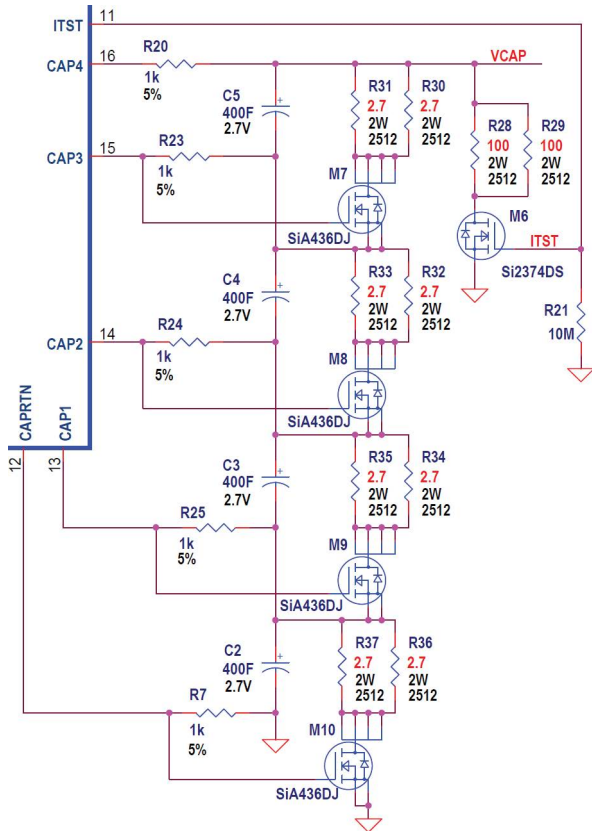

Figure 11. High Current Balancing/Shunting

CALCULATING THE CAPACITANCE

The calculation for the standard DC1937B is:

$$C_{STACK} = \frac{R_T}{R_{TST}} \cdot 336\mu F \cdot meas_cap$$

for large scale and

$$C_{STACK} = \frac{R_T}{R_{TST}} \cdot 3.36\mu F \cdot meas_cap$$

for small scale.

The LTC3350 pauses balancing when a capacitor/ESR measurement is being performed and the active balancing current is not needed in the capacitor measurement calculation. Some battery packs have built in passive balance resistors or sometimes resistors are connected in parallel to the supercapacitors for a higher balancing current. Any passive balancing current that is not controlled by the LTC3350 needs to be included in the capacitor measurement calculation. If passive balancing is used then the I_{BAL} term is used in the capacitor equation below, otherwise the I_{BAL} term is omitted from the calculation.

$$Time = R_T \text{ (in } \Omega) \cdot 56\mu F \cdot meas_cap \text{ for large scale.}$$

$$Time = R_T \text{ (in } \Omega) \cdot 0.56\mu F \cdot meas_cap \text{ for small scale.}$$

$$ITST_EXT \cong \frac{V_{CAP} - 0.1V}{R_{ITST_EXT}}$$

$$I_{BAL} \cong \frac{V_{CAP} - 0.1V^*}{R_{BAL_TOTAL}}$$

$$I_{TST} \cong \frac{1.2V}{R_{TST}}$$

$$C = \frac{(I_{TST} + ITST_EXT + I_{BAL}) \cdot TIME}{0.2V}$$

*The I_{BAL} term should only be used if passive balance resistors are connected in parallel with the supercapacitors or a capacitor stack with internal passive balancing are used. Typically this term is omitted.

PARTS LIST

ITEM	QTY	REFERENCE	PART DESCRIPTION	MANUFACTURER/PART NUMBER
Required Circuit Components				
1	4	C2-C5	CAP, ELECTRIC DOUBLE LAYER, 10F, 2.7V	NESSCAP, ESHSR 0010C0 002R7
2	1	C8	CAP, CHIP, COG, 120pF, ±5%, 25V, 0402	MURATA, GRM1555C1E121JA01D
3	2	C10, C25	CAP, CHIP, X5R, 0.1µF, ±10%, 25V, 0402	TDK, C1005X5R1E104K050BC
4	1	C11	CAP, CHIP, X5R, 1µF, ±10%, 25V, 0603	MURATA, GRM188R61E105KA12D
5	3	C12, C16, C24	CAP, CHIP, X7R, 0.1µF, ±10%, 16V, 0402	MURATA, GRM155R71C104KA88D
6	1	C13	CAP, CHIP, X5R, 4.7µF, ±10%, 6.3V, 0603	TDK, C1608X5R0J475K080AB
7	1	C14	CAP, CHIP, X5R, 1µF, ±10%, 16V, 0402	TDK, C1005X5R1C105K050BC
8	1	C15	CAP, 27µF, 25V, ALUM. ELECTRO, 20%, 6.3 × 4.5	SUN ELECT, 25HVH27M
9	1	C18	CAP, 0.01µF, X7R, 16V, 10%, 0402	AVX, 0402YC103KAT2A
10	2	C19, C20	CAP, CHIP, X5R, 47µF, ±20%, 25V, 1206	TDK, C3216X5R1E476M160AC
11	2	C22, C23	CAP, CHIP, X5R, 2.2µF, ±10%, 25V, 0402	TDK, C1005X5R1E225K050BC
12	4	C26, C27, C28, C29	CAP, CHIP, X5R, 22µF, ±10%, 16V, 0805	TDK, C2012X5R1C226K125AC
13	1	D1	DIODE, SWITCHING, 80V, 0.125A, SOD-523	DIODES INC, 1N4448HWT-7
14	1	L1	IND., PWR., SHIELDED, 3.3µH, 20%	COILCRAFT, XAL7030-332MEB
15	2	M1, M4	FET, N-MOS, 20V, 16A, POWER-PAK 1212-8	VISHAY, SIS438DN-T1-GE3
16	2	M2, M3	MOSFET N-CH 25V, 40A TSDSON-8	INFINEON, BSZ060NE2LS
17	1	R3	RES, CHIP, 649kΩ, ±1%, 1/16W, 0402	VISHAY, CRCW0402649KFKED
18	1	R4	RES, CHIP, 162kΩ, ±1%, 1/16W, 0402	VISHAY, CRCW0402162KFKED
19	1	R5	RES, CHIP, 787kΩ, ±1%, 1/16W, 0402	VISHAY, CRCW0402787KFKED
20	1	R6	RES, CHIP, 100kΩ, ±1%, 1/16W, 0402	VISHAY, CRCW0402100KFKED
21	5	R7, R20, R23, R24, R25	RES, CHIP, 2.7Ω, ±1%, 1/2W, 0805 WIDE	ROHM SEMI, LTR10EVHFL2R70
22	2	R8, R9	RES, CHIP, 100kΩ, ±5%, 1/16W, 0402	VISHAY, CRCW0402100KJNED
23	3	R12, R13, R14	RES, CHIP, 1kΩ, ±5%, 1/16W, 0402	VISHAY, CRCW04021K00JNED
24	1	R19	RES, CHIP, 0Ω JUMPER, 1/16W, 0402	VISHAY, CRCW04020000Z0ED
25	1	R21	RES, CHIP, 121Ω, ±1%, 1/16W, 0402	VISHAY, CRCW0402121RFKED
26	1	R22	RES, CHIP, 71.5kΩ, ±1%, 1/16W, 0402	VISHAY, CRCW040271K5FKED
27	1	R26	RES, CHIP, 866kΩ, ±1%, 1/16W, 0402	VISHAY, CRCW0402866KFKED
28	1	R27	RES, CHIP, 118kΩ, ±1%, 1/16W, 0402	VISHAY, CRCW0402118KFKED
29	1	RSNSC	RES, CHIP, 6mΩ, ±1%, 1W, 1632	SUSUMU, PRL1632-R006-FT1
30	1	RSNSI	RES, CHIP, 16mΩ, ±1%, 1W, 1632	SUSUMU, PRL1632-R016-FT1
31	1	U1	SUPERCAP BACKUP CONTROLLER	LINEAR TECH., LTC3350EUHF#PBF
Additional Demo Board Circuit Components				
32	1	C1	CAP, CHIP, X7R, 0.1µF, ±10%, 16V, 0402	MURATA, GRM155R71C104KA88D
33	2	C6, C7	CAP, CHIP, X5R, 1µF, ±10%, 25V, 0603	MURATA, GRM188R61E105KA12D
34	0	C9, C17	CAP, CHIP, 0402	
35	0	C21	CAP, 6.3 × 4.5	
36	3	D2, D3, D4	LED, SUPER RED, 660nm, 0603, 1.6 × 0.8mm	LUMEX, SML-LX0603SRW-TR
37	0	D5	DIODE ZENER, 5.6V, 250mW, DFN1006-2	DIODES INC, BZT52C5V6LP-7

DEMO MANUAL DC1937B

PARTS LIST

ITEM	QTY	REFERENCE	PART DESCRIPTION	MANUFACTURER/PART NUMBER
38	2	R1, R2	RES, CHIP, 20Ω, ±1%, 1/16W, 0402	VISHAY, CRCW040220R0FKED
39	0	R10, R11	RES, CHIP, 0402	
40	3	R15, R16, R18	RES, CHIP, 5.1kΩ, ±5%, 1/16W, 0402	VISHAY, CRCW04025K10JNED
41	1	R17	RES, CHIP, 1MΩ, ±5%, 1/16W, 0402	VISHAY, CRCW04021M00JNED
42	0	R28-R29	RES, CHIP, 2W, 2512	
43	0	R30-R37	RES, CHIP, 2W, 2512	
44	2	R38, R39	RES, CHIP, 2.4MΩ, ±5%, 1/16W, 0402	VISHAY, CRCW04022M40JNED
45	1	M5	MOSFET, N-CH 20V, 5.9A, SOT-23	VISHAY, SI2374DS-T1-GE3
46	0	M6	MOSFET, N-CH 20V, 5.9A, SOT-23	VISHAY, SI2374DS-T1-GE3
47	0	M7-M10	MOSFET, N-CH 8V, 12A, POWERPAK SC-70 6L	VISHAY, SIA436DJ
48	1	U2	I ² C EEPROM	MICROCHIP, 24LC025-I/ST

Hardware: For Demo Board Only

49	10	E1- E10	TURRET, 0.09 DIA	MILL-MAX, 2501-2-00-80-00-00-07-0
50	6	E11- E16	TURRET, 0.061 DIA	MILL-MAX, 2308-2-00-80-00-00-07-0
51	1	J1	CONN, 2x14 2mm HEADER	MOLEX, 87831-1420
52	1	JP1	HEADER, 3PINS, 2mm	WURTH, 62000311121
53	1	XJP1	SHUNT 2mm 1X3	WURTH, 60800213421
54	4		STAND-OFF, NYLON 0.50 tall	KEYSTONE, 8833(SNAP ON)
55	1		FAB, PRINTED CIRCUIT BOARD	DC1937B-3

SCHEMATIC DIAGRAM

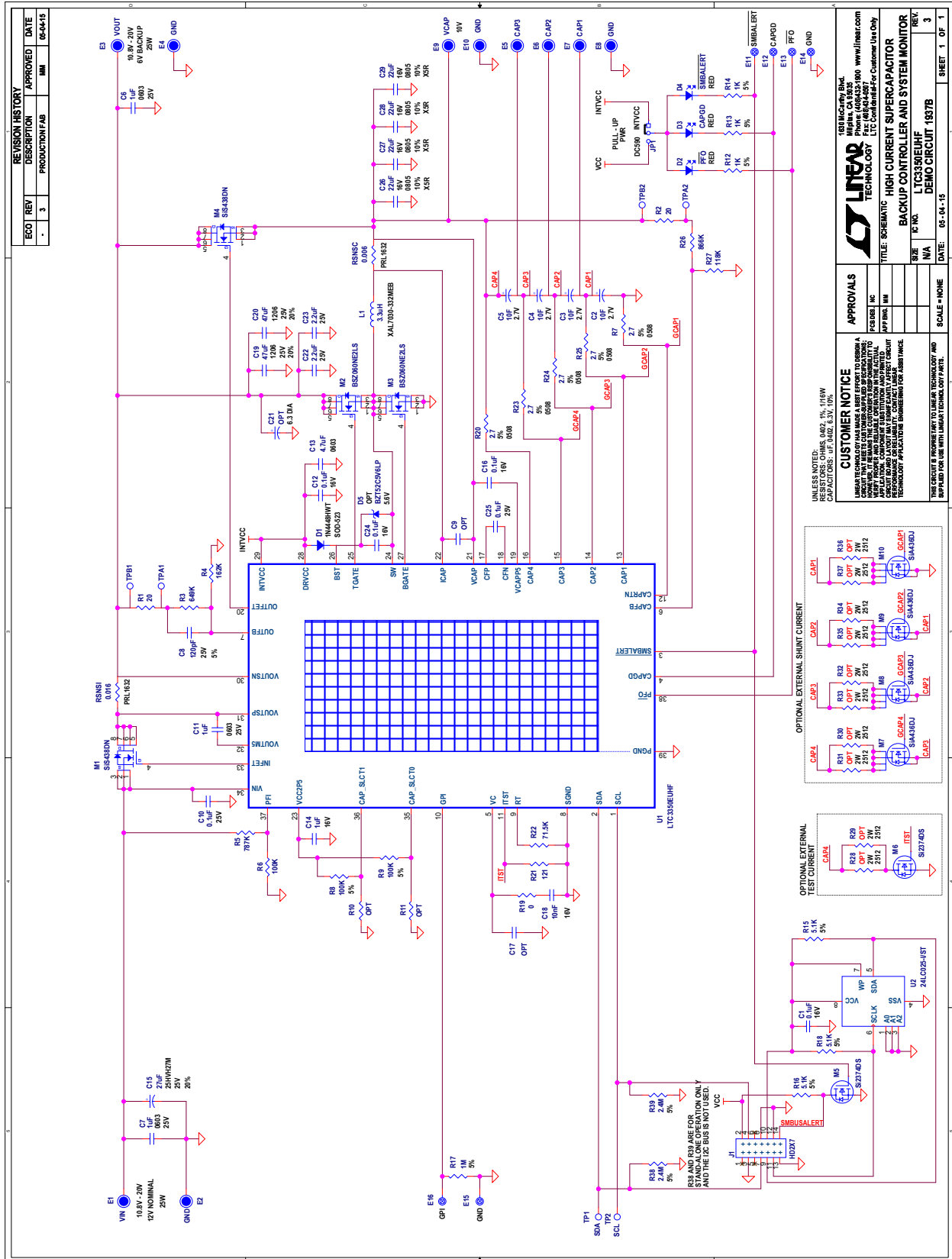

DEMO MANUAL DC1937B

DEMONSTRATION BOARD IMPORTANT NOTICE

Linear Technology Corporation (LTC) provides the enclosed product(s) under the following **AS IS** conditions:

This demonstration board (DEMO BOARD) kit being sold or provided by Linear Technology is intended for use for **ENGINEERING DEVELOPMENT OR EVALUATION PURPOSES ONLY** and is not provided by LTC for commercial use. As such, the DEMO BOARD herein may not be complete in terms of required design-, marketing-, and/or manufacturing-related protective considerations, including but not limited to product safety measures typically found in finished commercial goods. As a prototype, this product does not fall within the scope of the European Union directive on electromagnetic compatibility and therefore may or may not meet the technical requirements of the directive, or other regulations.

If this evaluation kit does not meet the specifications recited in the DEMO BOARD manual the kit may be returned within 30 days from the date of delivery for a full refund. **THE FOREGOING WARRANTY IS THE EXCLUSIVE WARRANTY MADE BY THE SELLER TO BUYER AND IS IN LIEU OF ALL OTHER WARRANTIES, EXPRESSED, IMPLIED, OR STATUTORY, INCLUDING ANY WARRANTY OF MERCHANTABILITY OR FITNESS FOR ANY PARTICULAR PURPOSE. EXCEPT TO THE EXTENT OF THIS INDEMNITY, NEITHER PARTY SHALL BE LIABLE TO THE OTHER FOR ANY INDIRECT, SPECIAL, INCIDENTAL, OR CONSEQUENTIAL DAMAGES.**

The user assumes all responsibility and liability for proper and safe handling of the goods. Further, the user releases LTC from all claims arising from the handling or use of the goods. Due to the open construction of the product, it is the user's responsibility to take any and all appropriate precautions with regard to electrostatic discharge. Also be aware that the products herein may not be regulatory compliant or agency certified (FCC, UL, CE, etc.).

No License is granted under any patent right or other intellectual property whatsoever. **LTC assumes no liability for applications assistance, customer product design, software performance, or infringement of patents or any other intellectual property rights of any kind.**

LTC currently services a variety of customers for products around the world, and therefore this transaction **is not exclusive**.

Please read the DEMO BOARD manual prior to handling the product. Persons handling this product must have electronics training and observe good laboratory practice standards. **Common sense is encouraged.**

This notice contains important safety information about temperatures and voltages. For further safety concerns, please contact a LTC application engineer.

Mailing Address:

Linear Technology
1630 McCarthy Blvd.
Milpitas, CA 95035

Copyright © 2004, Linear Technology Corporation