

## High Precision PSR Constant Current LED Driver

### Features

- Built-in 650V Power MOSFET
- Constant current control without secondary sense and feedback circuit.
- No Auxiliary winding for sensing and supplying
- Ultra low operating current to improve efficiency
- Universal input voltage
- $\pm 5\%$  LED current accuracy
- LED short and open circuit protection
- VCC under-voltage protection
- Over temperature protection
- Available in DIP-8 package

### Applications

- LED bulb, spot light
- Other LED lighting

### Description

The WS9226 is a high precision primary-side feedback and regulation controller for LED lighting, it operates in constant current control mode and is designed to work in inductor current discontinuous conduction mode and especially suitable for flyback convertor under universal input. The output power of system is recommended to less than 24W.

The WS9226 integrates 650V power MOSFET. Since adopting primary sense and feedback control technology, the secondary sense and feedback circuit is eliminated. The loop compensation components are also removed while maintaining stability overall operating conditions. The operating current is very low, and it doesn't need the auxiliary winding for sensing the output current and supplying the chip. The low component counts and small system size are realized.

Since using the proprietary high accurate current sense method, the WS9226 realizes  $\pm 5\%$  accuracy of LED current along with excellent line and load regulation.

The WS9226 offers rich protection functions including LED open/short circuit protection, over-temperature protection, VCC under voltage protection.

### Typical Application

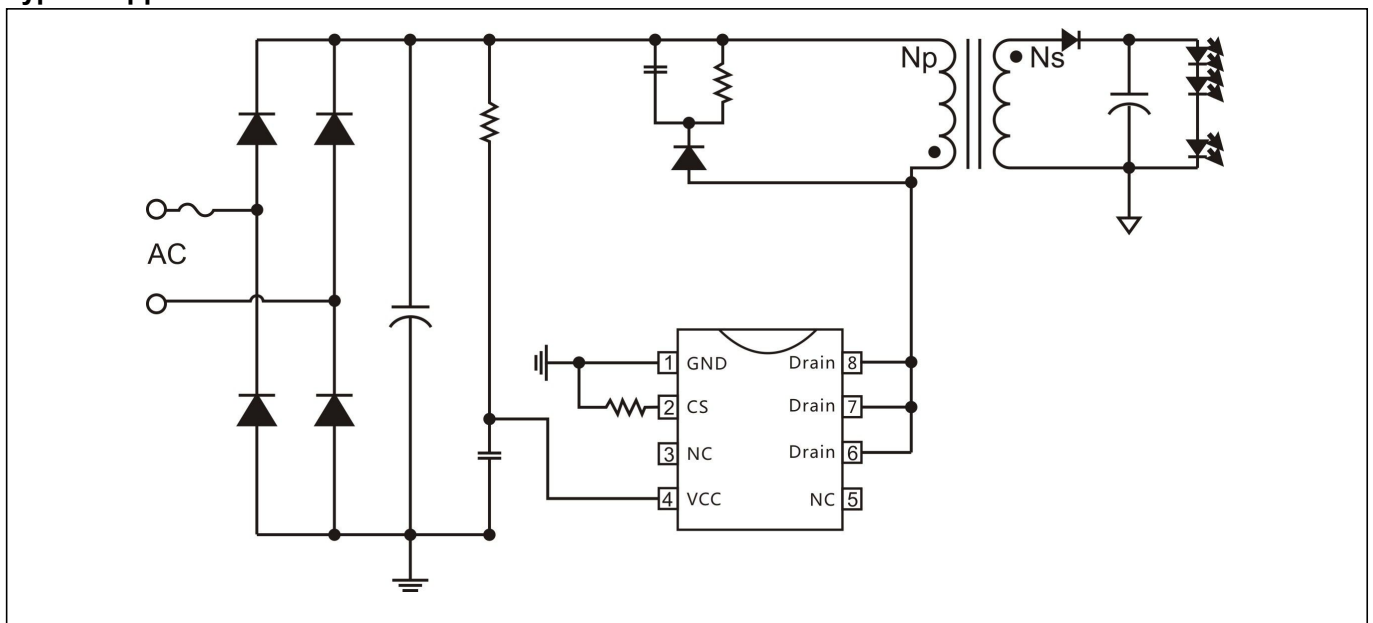

**Pin Configuration and Marking Information**

The WS9226 is available in DIP8 Package, the top marking is shown as below:

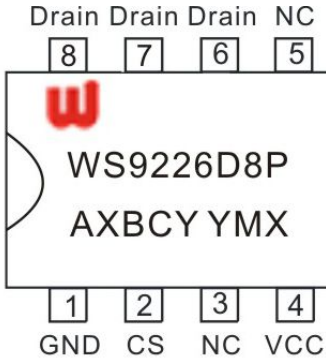

WS9226D8P  
 A: Product Code  
 X: Internal Code  
 BCY: Internal Code For QC  
 YMX: D/C

**Pin Definition**

Name	Pin No.	Description
GND	1	Ground
CS	2	Current sense. This pin connects a current sense resistor to GND to detect the primary current of transformer.
NC	3	No connection, must be floated
VCC	4	Power supply
NC	5	No connection, must be floated
DRAIN	6,7,8	Internal high voltage MOSFET Drain

**Internal Block Diagram**

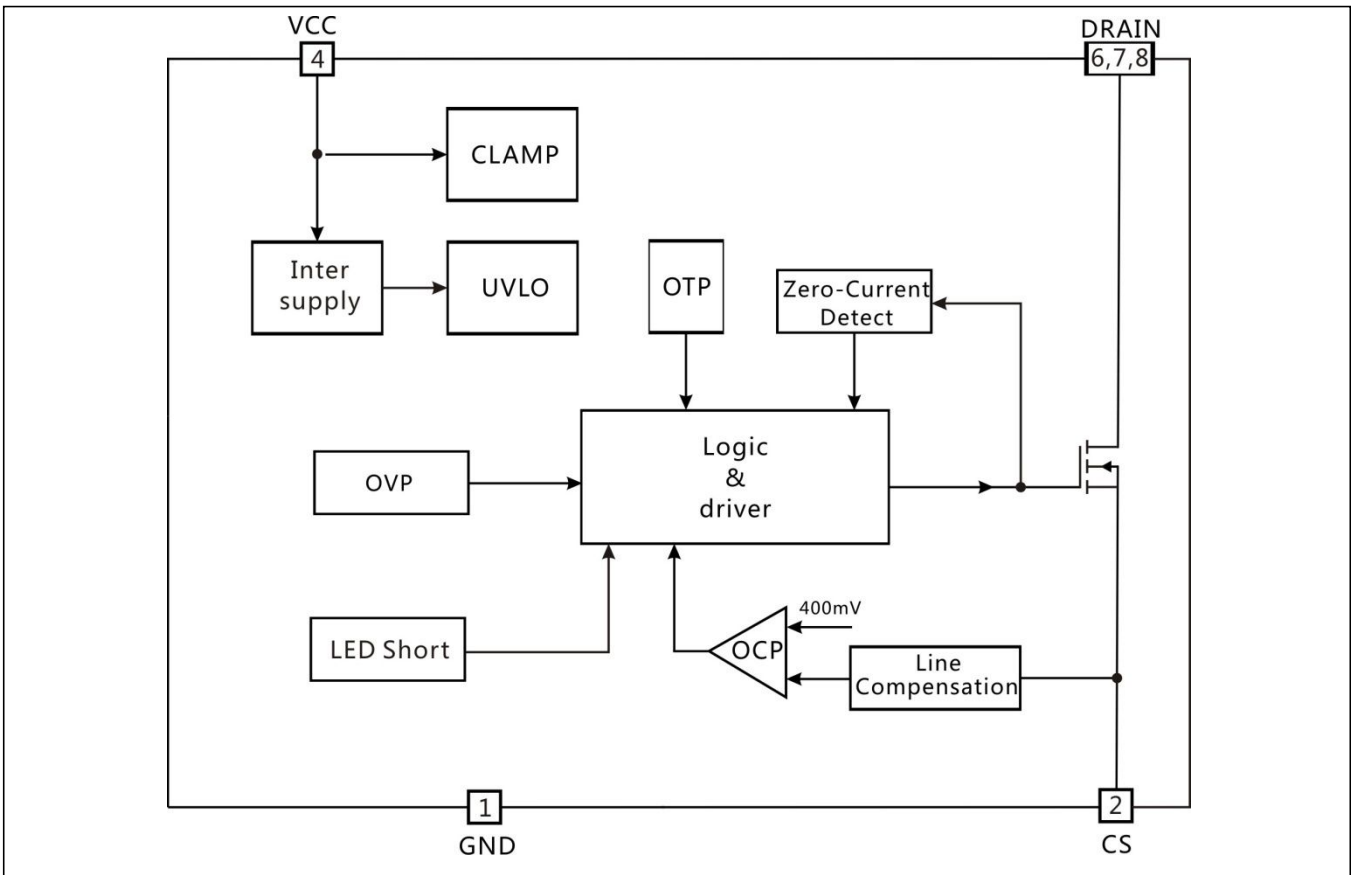

### Ordering Information

Package	Marking	Part Number
8-Pin DIP-8, Pb-free	WS9226D8P	WS9226D8P

### Recommended Operation Conditions

Part Number	Package	Input voltage	Maximum output power
WS9226D8P	DIP8	175VAC-264VAC	≤36W
		90VAC-264VAC	≤24W

### Absolute Maximum Ratings

symbol	paramete	Range	unit
I <sub>cc_max</sub>	VCC pin maximum sink current	2.5	mA
Drain	Internal HV MOSFET drain voltage	-0.3~650	V
CS	Current sense pin input voltage	-0.3~7	V
T <sub>J</sub>	Operating junction temperature	165	°C
T <sub>STG</sub>	Storage temperature range	-55~165	°C

**Note 1:** Stresses beyond those listed under “absolute maximum ratings” may cause permanent damage to the device.

**Electrical Characteristics** (Unless otherwise specified, VCC=8V and TA =25 °C)

Symbol	Parameter	Conditions	Min	Typ	Max	Units
<b>Supply Voltage Section</b>						
V <sub>CC_Clap</sub>	VCC clamp voltage	1mA	17.8	18.8	19.8	V
UVLO_off	Turn-off threshold Voltage		14.3	15.3	16.3	V
UVLO_on	Turn on threshold Voltage		9	9.5	10	V
I <sub>ST</sub>	VCC startup current	VCC= 13V	150	205	250	uA
I <sub>OP</sub>	VCC operating current	Fop=70KHz		140		uA
<b>Current Sense Section</b>						
V <sub>CS_TH</sub>	Threshold voltage for peak current limit		390	400	410	mV
T <sub>LEB</sub>	Leading edge blanking time for current sense			350		ns
T <sub>DELAY</sub>	Switch off delay time			200		ns
<b>Internal driver Section</b>						
Toff_max	Maximum Off Time			310		us
Toff_min	Minimum Off Time			3.5		us
Ton_max	Maximum On Time			100		us
Tons_OVP	Output OVP Threshold Time			7		us
<b>MOSFET Section</b>						
R <sub>DS_ON</sub>	Static drain-source on-resistance			1.55	1.8	Ω
BV <sub>DSS</sub>	Drain-source breakdown voltage		650			V
I <sub>DSS</sub>	Drain-source leakage current				10	uA
<b>Over Temperature Protection</b>						
T <sub>REG</sub>	Thermal Regulation Temperature			150		°C

## Application Information

The WS9226 is a high performance power switch specially designed for LED lighting, with patent constant current control technology. The WS9226 integrates a 650V power MOSFET. The accurate LED current can be realized without opto-coupler, TL431 feedback circuit and auxiliary winding while minimizing the external component count, lowering the total bill of material cost.

## Start Up

The start-up current in WS9226 is designed to as low as 205uA. The VCC capacitor will be charged through the start-up resistor when the system is powered on. Once the VCC voltage reaches the start-up threshold, the WS9226 will start to switch. The WS9226 integrates a 19V zener for VCC clamping. Due to the ultra-low operating current, the auxiliary winding is not needed to supply the IC.

## Constant Current Control

Cycle-by-Cycle current sense is adopted in WS9226, the CS is connected to the current sense comparator, and the voltage on CS will be compared with the internal 400mV reference voltage, the MOSFET will be switched off when the voltage on CS reaches the threshold. The output of the comparator includes a 350ns leading edge blanking time.

The primary peak current is given by:

$$I_{P\_PK} = \frac{400}{R_{CS}} (mA)$$

The current in LED can be calculated by the equation:

$$I_{OUT} = \frac{I_{P\_PK}}{4} \times \frac{N_P}{N_S}$$

Where,

NP: primary winding turns of transformer

NS: secondary winding turns of transformer

IP\_PK: peak current in MOSFET

## Power MOSFET

The WS9226 integrates a 650V power N-MOSFET. It can minimize the external component count and reduce the BOM cost and PCB size.

The WS9226 uses DIP-8 package. The recommended system output power is below 24W in universal input (90Vac~265Vac) application.

## Operating Switching Frequency

The WS9226 is designed to work in discontinuous conduction mode and no external loop compensation component is required while maintaining stability. The maximum duty cycle is limited to 42%. The maximum switching frequency at normal operation is suggested to set around 65KHz~70KHz. If the maximum frequency is set too high, it will affect the number of maximum series LED lamps. If set too low, the LED open circuit voltage will be too high.

The maximum and minimum switching frequency is limited in WS9226 to ensure the stability of system.

The switching frequency can be set by the formula:

$$f = \frac{Np^2 \times V_{LED}}{8 \times Ns^2 \times Lp \times I_{LED}}$$

Where, LP is the primary winding inductance of transformer.

## Protection Function

The WS9226 has integrated rich protection functions, LED open/short protection, CS resistor short circuit protection, VCC under voltage protection, over temperature protection, and so on. When the LED is open circuit, it will trigger over-voltage protection logic and latch, the system stops switching immediately.

When the LED short circuit is detected, the system works at low frequency (Fop=3KHz), so the power consumption is low. After the system enters into fault latch condition, the VCC voltage will fall until it reaches UVLO threshold. Then the system will re-start again. If the fault condition is removed, the system will recover to normal operation.

## PCB Layouts

The following rules should be followed in WS9226 PCB layout

### Bypass Capacitor

The bypass capacitor on VCC should be as close as possible to the VCC pin and GND pin.

### Ground Path

The power ground path for current sense should be short, and the power ground path should be separated from small signal ground path before the negative of the bulk capacitor.

### The Area of Power Loop

The area of main current loop should be as small as

possible to reduce EMI radiation, such as the primary current loop, the snubber circuit and the secondary rectifying loop.

**NC Pin**

The NC pin must be left floating to satisfy the requirement of creepage distance.

**Drain pin**

To increase the copper area of drain for thermal consideration.

**Package Information**

**DIP8Package Outline Dimensions**

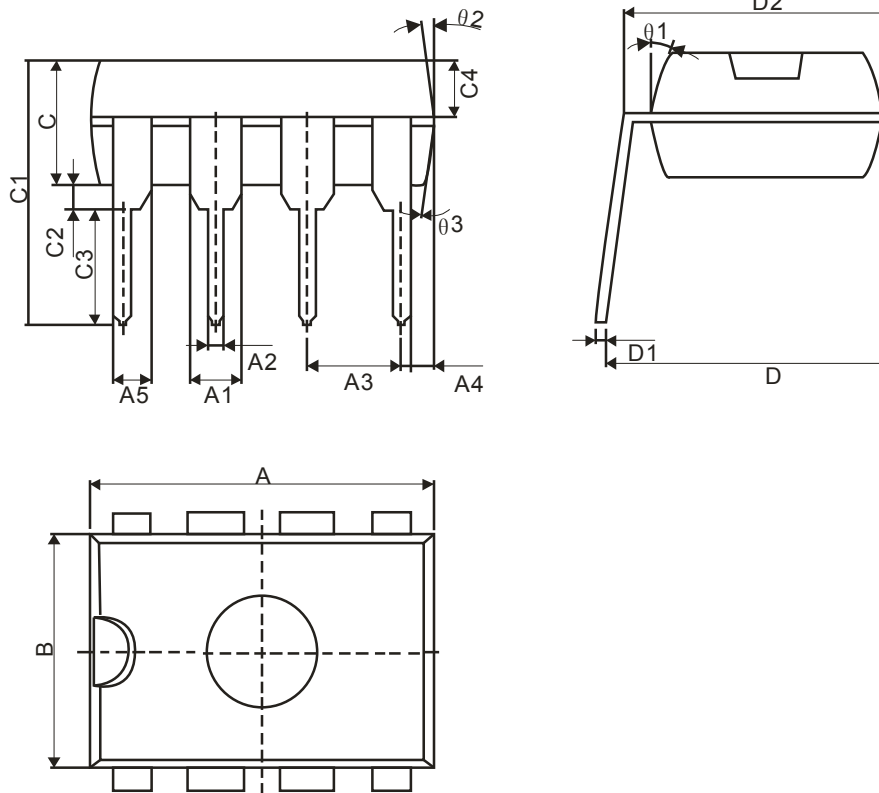

Winsemi				
Symbol	Dimensions in Millimeters		Dimensions in Inches	
	Min	Max	Min	Max
A	9.00	9.50	0.354	0.374
B	6.10	6.60	0.240	0.260
C	3.0	3.4	0.118	0.134
A1	1.474	1.574	0.058	0.062
A2	0.41	0.53	0.016	0.021
A3	2.44	2.64	0.096	0.104
A4	0.51TYP		0.02TYP	
A5	0.99TYP		0.04TYP	
C1	6.6	7.30	0.260	0.287
C2	0.50TYP		0.02TYP	
C3	3.00	3.40	0.118	0.134
C4	1.47	1.65	0.058	0.065
D	7.62	9.3	0.300	0.366
D1	0.24	0.32	0.009	0.013
D2	7.62TYP		0.3TYP	

**NOTE:**

- 1.We strongly recommend customers check carefully on the trademark when buying our product, if there is any question, please don't be hesitate to contact us.
- 2.Please do not exceed the absolute maximum ratings of the device when circuit designing.
- 3.Winsemi Microelectronics Co., Ltd reserved the right to make changes in this specification sheet and is subject to change without prior notice.

**CONTACT:**

Winsemi Microelectronics Co., Ltd.

ADD:Futian District, ShenZhen Tian An Cyber Tech Plaza two East Wing 1002

Post Code : 518040

Tel : +86-755-8250 6288

FAX : +86-755-8250 6299

Web Site : [www.winsemi.com](http://www.winsemi.com)